















13	ENGINES AND AROUND THE ENGINE	
61	STERN GEAR SYSTEMS	
81	EXHAUST SYSTEMS	
101	BOAT INSTRUMENTS	
119	FUEL SYSTEMS	
135	FRESH WATER SYSTEMS	
149	WASTE WATER SYSTEMS	
169	MANEUVERING SYSTEMS	
197	POWER HYDRAULICS	
219	ELECTRICITY ON BOARD	
235	STEERING SYSTEMS	
259	GLAZING SYSTEMS	
287	VENTILATION	
301	MAXWELL ANCHORING SYSTEMS	
345	V-EQUIPMENT	

VETUS, CREATORS OF BOAT SYSTEMS

Why choose VETUS?

VETUS supplies complete boat systems. We are not just a wholesaler, nor do we focus on one product - we are industry wide specialists who design complete systems. Systems meticulously engineered to one another so they go together like a dream. VETUS is the one-stop-shop you are looking for, whether you need a complete propulsion system or only a waterlock. An advisory partner with knowledge of both technique and market, who has a global network and offers a unrivalled service. VETUS - for boaters by boaters.

Who are we?

VETUS was founded in 1964 and started out as a wholesale business. Our goal: to be the leading company in innovative systems and products for pleasure boats and light duty commercial vessels. Our mission is to constantly provide the best products and service in the business. We bring the most innovative and sustainable solutions to our customers to enhance their pleasure in boating.

Who we are. We are VETUS, creator boat systems

Our brands

Throughout the years we have acquired some businesses, each keeping their specialism. We now consist of:

VETUS - complete product systems numbering over 3700 high quality products

Over 70% of our quality products are partly or completely developed in-house. Only the most knowledgeable and experienced companies are added to our list of selected partners, but only when we've verified those are the best match to our self-developed products. We've developed many innovations, such as the EP2200 (electric propulsion: introduced early 2000) and the BOW PRO thrusters (brushless bow thrusters: introduced in 2018) to name just a few.

Maxwell - anchoring systems to stay in position: at the top

For over 50 years Maxwell has been known for its comprehensive programme of windlasses, capstans and accessories providing optimal anchoring solutions for pleasure boats/yachts (from 6-90 metres) and commercial vessels. In the marine industry Maxwell's products are renowned for their quality, innovative design, performance and reliability. Maxwell made the world's first automatic rope/chain windlass in the mid 90's and is known for its Freedom series which have been replaced by the brilliantly evolved RC series.

Marex - providing clear vision since 1950

Marex is a leading manufacturer of custom made boat windows. Marex stands for quality, innovation and stylish design. Offering several base product ranges including the outstanding Marex Screw-On line, Marex Comfort Line and the Marex Exclusive Line.

V-Quipment - auxiliary items to meet the needs of every boat owner

V-Quipment has a diverse range of high quality, carefully selected marine products to complement our VETUS range. That range is divided into theme groups: Comfort, Deck Equipment, Fittings, Pumps, Outboard, Inflatable boats, Materials, Accessories, Locks and Stays. All V-Quipment products are tested and approved in the VETUS test lab in Schiedam (The Netherlands) and therefore carry our 3-year warranty.

Warranty and service

Service wherever you are in the world

VETUS has a worldwide service programme that offers you not only a 3-year warranty for equipment and a 5-year warranty for engines, but also guarantees service wherever you are in the world! These warranty periods are unique in the leisure marine world and are an additional reason for you to choose VETUS products. Our global service network will be of your assistance all around the world.

3-Year warranty VETUS equipment

We want you to enjoy life on the water and not be let down by product failures. Confidence in your boat and equipment is essential. That is why VETUS offers a 3-year warranty on your equipment and a worldwide service network. Our customers can always count on outstanding support.

5-Year warranty VETUS engines

For the first 36 months after the date of delivery to the first owner, all VETUS diesel propulsion engines are fully warranted in accordance with the conditions as specified in the VETUS Owner's manual. For an additional period of 24 months or 1000 additional operating hours -whichever comes first- VETUS offers an **extended limited warranty** covering the specific parts. The exact parts, and the complete terms and conditions, can be found on our website www.vetus.com

5+ extended warranty for VETUS package deals

When a VETUS engine is purchased together with a complete VETUS around the Engine package, warranty will be extended from 3 to 5 years on the around the engine package. Together with the already very good warranty conditions on VETUS engines (3+2 years) VETUS products will ensure you to have a long and carefree use of your boat! Please see www.vetus.com/en/5-plus-warranty for more information.

VETUS, CREATORS OF BOAT SYSTEMS

Yanmar Marine International



Since 2013 VETUS is part of the Yanmar Marine International.

Leveraging the latest technologies, Yanmar Marine International is creating and building tomorrow's most innovative diesel marine engines, with the same level of quality and dependability that has earned your trust. Our connected, smart and environmentally responsible products demonstrate there are no limits to the future of marine propulsion. But this is only half of the equation.

Yanmar is more than a forward-looking engine company. Our mission is to provide sustainable solutions that enrich and improve people's lives. It is our commitment, our responsibility and our passion.

To achieve this vision, we are actively listening to the needs and desires of our customers, and delighting them with imaginative and groundbreaking integrated boat systems, at the heart of which is the Yanmar engine. The concept of a total system is the result Yanmar Marine International's building of a group of over 60 subsidiary and partner companies. Together, our goal is to provide everything a boat owner needs, whether for sailboat, powerboat or commercial vessel use—each tested and proven in real-world conditions.

Yanmar Partners & Affiliates



GETMYBOAT



Certification

We take our responsibilities very seriously

VETUS is ISO 9001:2015 certified, meaning that we guarantee our quality by working according to certain established guidelines and processes which we monitor continuously. We are committed to delivering quality and service. This important certificate is a confirmation of our commitment.

Below you will find the organisations that have been accredited by a European Union Member State and International Inspection Agencies to assess whether our products meet established standards through assessment, inspection and examination of a product, its design and manufacturer.

- CE guidelines e.g. RCD (Recreational Craft Directive)
- MED (Marine Equipment Directive)
- EMC (Electromagnetic Compatibility Directive)
- LVD (Low Voltage Directive)
- ABYC (American Boating and Yachting Council)
- NMMA (National Marine Manufacturers Association)



VETUS online

Keeping you up-to-date with the latest activities

Our complete product range can be found on our website www.vetus.com. Next to new product introductions and activities such as boat shows, you will also find our product manuals, instructional videos and frequently asked questions.

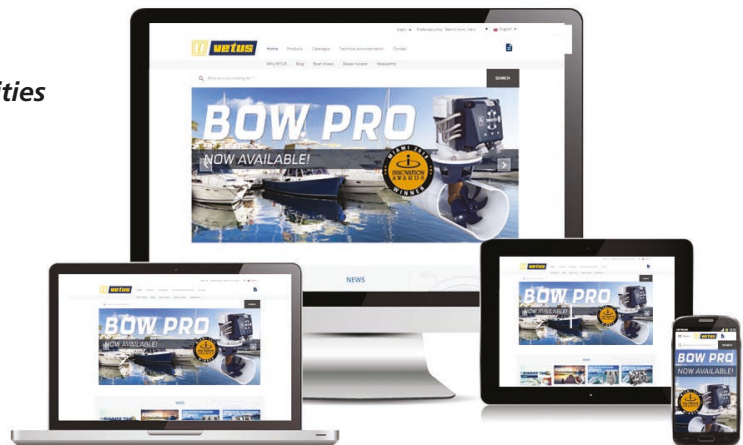

NEW PRODUCTS



VF-4
See page 29

**All purpose tank,
type APT100**

See pages
130, 140, 161



CWS
See page 53



V-DOCKER Joystick
See page 188



**Self-aligning inner
bearing, type ZWBH**
See page 73



**Accumulator,
type EXPAT075**
See page 145



TWINLINEC/D
See page 293



**Electric bow thruster,
type Bow PRO**
See page 178

**Accumulator,
type EXPAT075**
See page 145



**Bow PRO panels,
BPPPA and BPPJA**
See page 191



**Battery,
type VEDC110TC**
See page 230



Dashboard gauges
See page 111



**Steering wheel series,
type SW**
See page 243



MAREX

Hopper Window

See page 273



Porthole, PA Series

See page 267

MAXWELL



Heavy duty drum winch, TASMAN Series

See page 328

V-QUIPMENT

Seaman

See page 350



Pilot in black

See page 349



Stand-up paddle board

See page 394



RIB Frontier

See page 394



Private seat

See page 352



Captain

See page 351

FURTHER DEVELOPMENTS

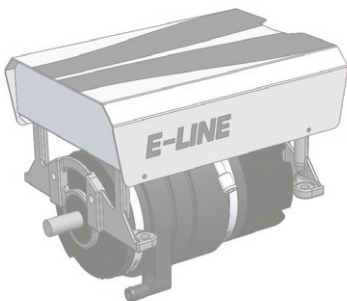

E-Line

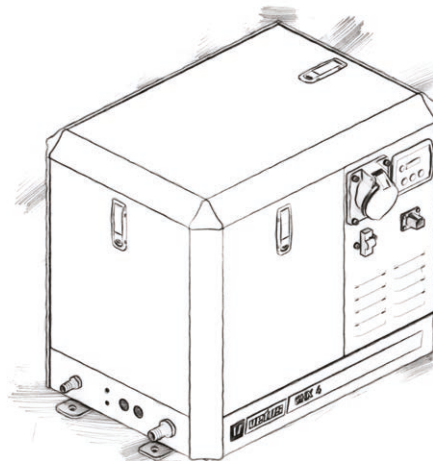

GHX4/5



SERVICE & DISTRIBUTION NETWORK

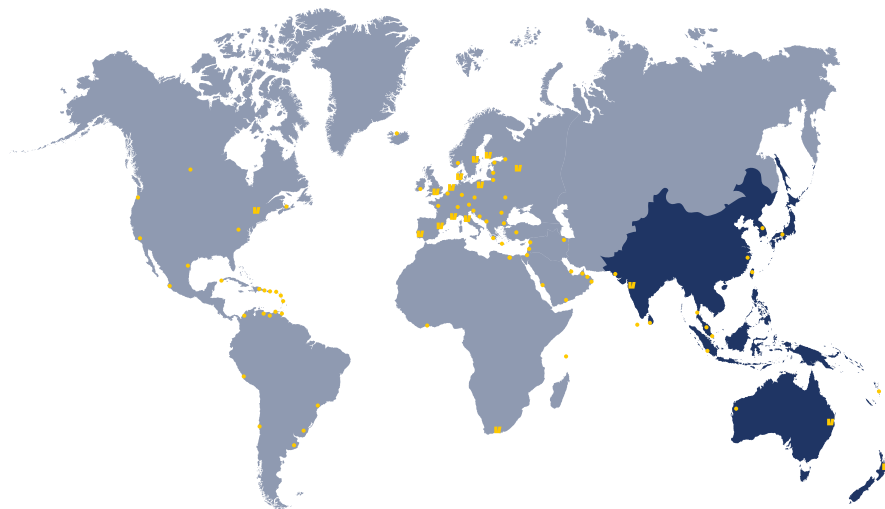

Head office and subsidiaries

VETUS B.V.

Fokkerstraat 571
3125 BD Schiedam-Holland
Tel.: + 31 (0)10 4377700
sales@vetus.com (export)
info@vetus.com (NL)

Asia

VETUS-Maxwell
Tel.: +886 909 390 358
salesasia@vetus-maxwell.com

Australia

VETUS-Maxwell Pty Ltd
Tel.: +61 (0)7 3245 4755
salesau@vetus-maxwell.com

Belgium

VETUS Belgium
Tel.: +32 499 82 57 22
info@vetus.be

Denmark

VETUS ApS
Tel.: +45 76 975 000
info@vetus.dk

Finland

VETUS Oy
Tel.: +358 207 756 740
info@vetus.fi

France

VETUS SARL
Tel.: +33 4 94 14 93 53
info@vetus.fr

India

VETUS Maxwell India
Tel.: +912 265 346 225
rjani@vetus.com

Italy

VETUS Maxwell Italia srl
Tel.: +39 0571 57122 / 073281
info@vetusitalia.it

New Zealand

VETUS-Maxwell Apac
Tel.: +64 (0) 9 985 66 00
salesnz@vetus-maxwell.com

Poland

VETUS Sp. z o.o.
Tel.: +48 22 452 40 52
+48 22 452 40 53
info@vetus.pl

Portugal

VETUS Portugal
Tel.: +351 211 328582
info@vetus.pt

Russia

VETUS
Tel.: +7 812 336 3915 /
+358 207 756 744
info@vetus.ru

South Africa

VETUS Maxwell South Africa
Tel.: +27 21 552 42 75
info@vetus.co.za

Spain

VETUS Hispania S.A.
Tel.: +349 02 101 883
vetus@vetus.es

Sweden

VETUS AB
Tel.: +46 854 444 270
info@vetus.se

United Kingdom

VETUS Ltd.
Tel.: +44 23 8045 4507
sales@vetus.co.uk

United States

VETUS Maxwell AMERICA
(Head office for North,
Middle and South America
and the Caribbean)
Tel.: +1 410 712 0740
sales-service@vetus.com

APAC Asia Pacific

Asia

VETUS-Maxwell
Tel.: +886 909 390 358
salesasia@vetus-maxwell.com

Australia

VETUS-Maxwell Pty Ltd
Tel.: +61 (0)7 3245 4755
salesau@vetus-maxwell.com

New Zealand

VETUS-Maxwell Apac
Tel.: +64 (0) 9 985 6600,
salesnz@vetus-maxwell.com

China

Shanghai Yikang
Chemical & Industries Co., Ltd
Tel.: +86 021 52419090
wayne.jin@yk.wahlee.com

Hong Kong

Ronsil Development Ltd.
Tel.: +852 2834 1633
ronsil@netvigator.com

Indonesia

PT Jelajah Samudera
Internasional
Tel.: +62 812-2515-7712 /
+62 813-2653-3543
jelajah_samudera@yahoo.com

PT Sumber Marine Equipment

Tel.: +6221 690 06 31
inbox@sumber-marine.com

Japan

Marine Services
Kojima Co., Ltd.
Tel.: +81 45 790 35 81
toiawase@mskojima.co.jp

Korea

Nadae-Soonshin Technology
Tel.: +82 51 832 15 95
boatcreator@soonshin.kr

Malaysia

Edaran Marin Centre Sdn Bhd
Tel.: +603 80 52 11 11
edaranmarin@gmail.com

Maldives

Marine Equipments pvt Ltd.
Tel.: +960 333 88 20
sales@marineequipments.com.mv

New Caledonia

Limousin Marine
Tel.: +687 274186/282295
limousin@canl.nc

Pacific Islands

see Australia

Singapore

Best Marine Electrical
Tel.: +65 674 10 317
bme17@singnet.com.sg

Sri Lanka

Neil Fernando & Co. Pvt Ltd.
Tel.: +94 11 574 07 67
nkfernando@neilmarine.com

Taiwan

Maxwell
Merc. International
Trade Co., Ltd.
Tel.: +886 7 813 3233 / 5
mms46654@ms16.hinet.net

Thailand

Electrical Marine co.,Ltd.
Tel.: +66 76 510 782
sales@electrical-marine.com

SERVICE & DISTRIBUTION NETWORK

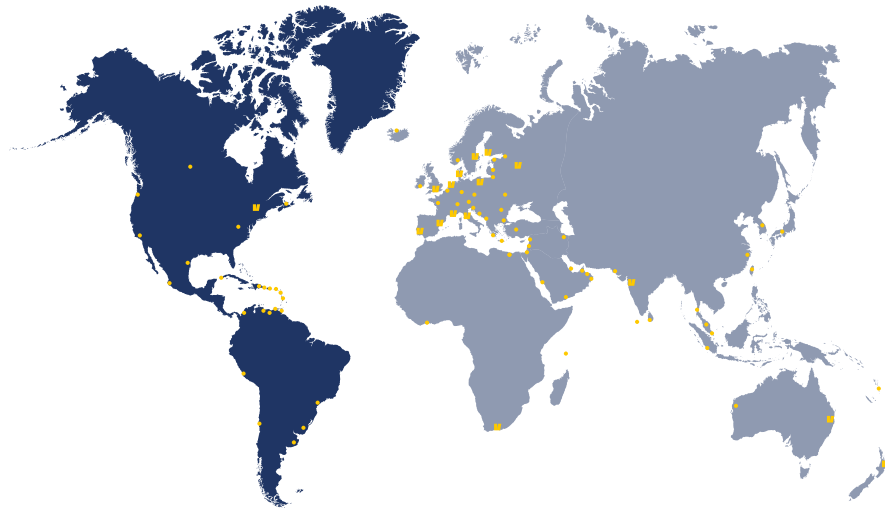

Americas and the Caribbean

United States

VETUS Maxwell America
(Head office for North and South America and the Caribbean)
Tel.: +1 410 712 0740
sales-service@vetus.com

Argentina

see United States

Maxwell
Trimer
Tel.: +54 11 4580 0444
Email: trimer@trimer.com.ar

Brazil

Marine Office Com. Imp.
e Repr. Ltda
Tel.: +55 11 34775655
marine.office@marineoffice.com.br

Canada

Stright-Mackay Ltd.
Tel.: +1 800 565 4394
info@stright-mackay.com

Western Marine

Tel.: (604) 253 3322

The Caribbean

Antigua
Budget Marine
Jolly Harbour Boatyard
Tel.: +268 462 8753
Antigua@budgetmarine.com

Aruba

Budget Marine Aruba
Tel.: +297 585 3796
aruba@budgetmarine.com

Bonaire

Budget Marine
Tel.: +599 717 3710
Bonaire@budgetmarine.com

British Virgin Islands

Nanny Cay Chandlery
Tel.: +284 494 2512
chandlery@nannycay.com

Parts & Power
Tel.: +284 494 2830
tom@partsandpower.com

Curacao

Budget Marine
Tel.: +599 462 7733
Curacao@budgetmarine.com

Budget Marine
Boat Yard
Tel.: +599 465 5686
parera@budgetmarine.com

Grenada

Budget Marine
Prickly Bay
Tel.: +473 439 1983
Grenada@budgetmarine.com

Island Water World
St. George's
Tel.: +473 435 2150/1
sales@islandwaterworld.com

Island Water World
St. David's Harbour
Tel.: +473 443 1028
sales@islandwaterworld.com

Puerto Rico

Martinez Marine
Puerto Del Rey Marina
Tel.: +1 787 863 4646
martinezmarine@hotmail.com

St. Lucia

Island Water World
Rodney Bay Marina
Tel.: +758 452 1222
sales@islandwaterworld.com

St. Maarten

Budget Marine
Tel.: +721 544 3134
sales@budgetmarine.com

Island Water World
Tel.: +721 544 5310
sales@islandwaterworld.com

St. Thomas

Budget Marine
Independent Boatyard
Tel.: +340 779 2219
StThomas@budgetmarine.com

Trinidad

Budget Marine
Chaguaramas
Tel.: +868 634 2006
sales@budmar.co.tt

LP Marine & Industrial
Supplies Ltd.
Tel.: +868 633 3395
info@lpmarinett.com

Chile

Motonautica Chile S.A.
Tel.: +562 757 7900
info@motonautica.cl

Colombia

Transmidiesel LTDA.
Tel.: +57 2 414 0000
emiliod@transmidiesel.com

Mexico

Zaragoza Marine
Tel.: +52 322 226 3232
info@zaragoza.com.mx

Peru

Fibrecon Pacific Marine SAC
Tel.: +51 1 348 1500 ex 302
jesus.vargas@fibreconmarine.com.pe

Rivera Diesel Amazonica SAC
Tel.: +51 1 065 234 221
manuel.salazar@fibreconmarine.com.pe

United States

VETUS Marine (Florida)
(independent distributor)
Tel.: +1 321 454 3375
sales@vetusmarine.com

Defender Industries Inc.
(National)
Tel.: +1 800 628 8225
www.defender.com

TDC Equipment Inc.
(South West)
Tel.: +1 714 373 8099
info@tdcequipment.com

Hamilton Marine (Maine)
Tel.: +1 207 548 6302
whamilton@hamiltonmarine.com

Fisheries Supplies Inc.
(North West)
Tel.: +1 800 429 6930
+1 206 632 4462
help@fisheriessupply.com

Marysville Marine
Distributors Inc.
(Mid West)
Tel.: +1 810 364 7653
marketing@marysvillemarine.com

Jamestown Distributors Inc.
(North East)
Tel.: +1 401 253 3840
+1 800 423 0030
info@jamestowndistributors.com

Fawcett Boat Supplies
(Maryland)
Tel.: +1 800 456 9151
+1 410 267 8681
info@fawcettboat.com

Paxton Company
(North East)
Tel.: +1 800 234 7290
+1 757 853 6781
www.paxtonco.com

Marine Equipment and
Supply Co.
(wholesale)
Tel.: +1 856 853 8320
www.mesconet.com

Seacoast Distributors LLC
Tel.: +1 631 884 1013
www.mesconet.com

Donovan Marine Inc.
(Gulf Coast)
Tel.: +1 504 488 5731
www.donovanmarine.com

West Marine
(National)
Tel.: +1 800 262 8684
+1 831 728 2700
www.westmarine.com

Jerry's Marine Service
(South East)
Tel.: +1 843 554 3732 (SC)
+1 954 525 0311 (FL)
info@jerrysmarine.com

CWR Electronics
(wholesale)
Tel.: +1 800 527 3306
www.cwrelectronics.com

SeaWide Distribution
(National)
Tel.: +1 866 732 9433
www.seawide.com

AER Supply
(Gulf Coast)
Tel.: +1 800 767 7607
www.aersupply.com

Mauri Pro Sailing
(National)
Tel.: +1 888 756 8883
www.mauriprosailing.com

Uruguay

Alvaro Bermúdez Náutica
Tel.: +598 2 628 8059
info@nautica.com.uy

SERVICE & DISTRIBUTION NETWORK

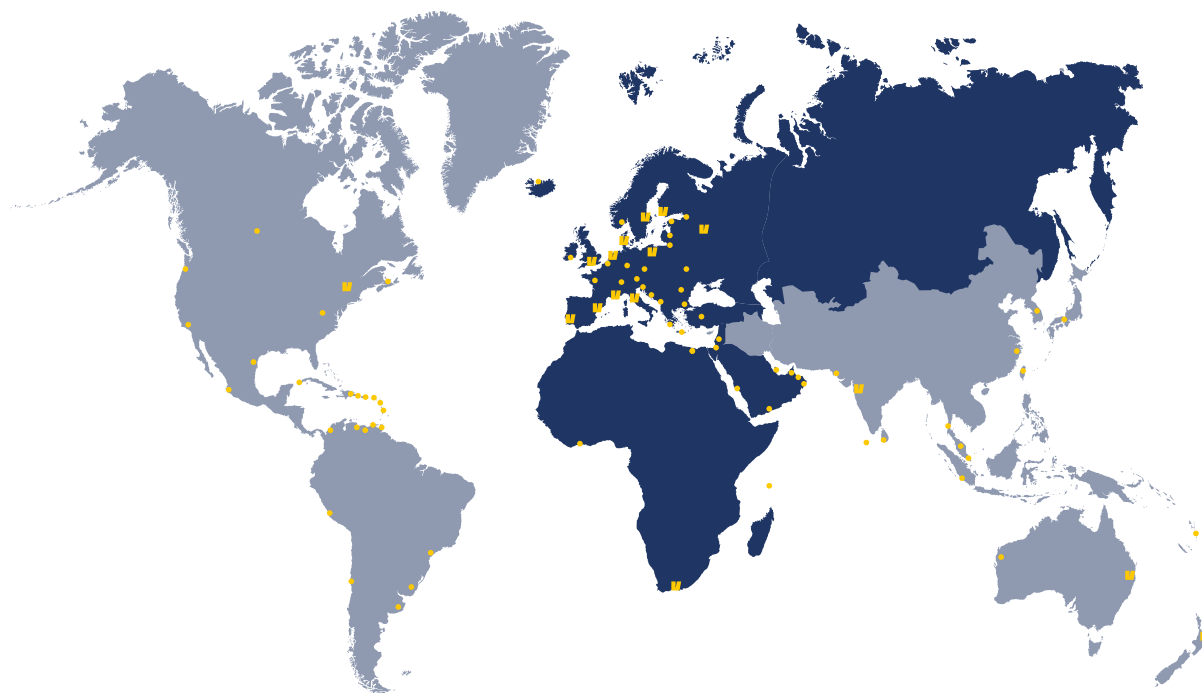

EMEA Europe, Middle East and Africa

VETUS B.V.

Fokkerstraat 571
3125 BD Schiedam-Holland
Tel.: +31 (0)10 4377700
info@vetus.com (NL)
sales@vetus.com (export)

Belgium

VETUS
Tel.: +32 499 82 57 22
info@vetus.be

Denmark

VETUS ApS
Tel.: +45 76 975 000
info@vetus.dk

Finland

VETUS Oy
Tel.: +358 207 756 740
info@vetus.fi

France

VETUS SARL
Tel.: +33 4 94 14 93 53
info@vetus.fr

Italy

VETUS Maxwell Italia srl
Tel.: +39 0571 57122 / 073281
info@vetusitalia.it

Poland

VETUS Sp. z o.o.
Tel.: +48 22 452 40 52 /
+48 22 452 40 53
info@vetus.pl

Portugal

VETUS Portugal
Tel.: +351 211 328582
info@vetus.pt

Russia

VETUS
Tel.: +7 812 336 3915 /
+ 358 207 756 744
info@vetus.ru

South Africa

VETUS Maxwell
South Africa
Tel.: +27 21 552 4275
info@vetus.co.za

Spain

VETUS Hispania S.A.
Tel.: +34 902 101 883
vetus@vetus.es

Sweden

VETUS AB
Tel.: +46 854 444 270
info@vetus.se

United Kingdom

VETUS Ltd.
Tel.: +44 23 8045 4507
sales@vetus.co.uk

Angola

Proa
Tel.: +244 923 579 173/
luis.sousa@proa-angola.com

Austria

Bukh-Bremen GmbH
Tel.: +49 421 535070
info@bukh-bremen.de

Bahrain

VETUS
see United Arab Emirates

Maxwell

Al Dhaen Craft
Tel.: +973 1773 7111
aldhaen@batelo.com.bh

Bulgaria

Yacht Center Varbanov Ltd.
Tel.: +359 56 843 232
mail@yachtbg.com

Croatia

WASI d.o.o.
Tel.: +385 13 498 248
wasi@wasi.hr

Cyprus

M.D.I. Mercury Co. Ltd.
Tel.: +357 25877933
mercury@mercury.com.cy

Czech Republic

GM NAVALE s.r.o.
Tel.: +420 731 464 898
info@gmnavale.cz

Egypt

Dolphin Marine Co
Tel.: +2012 7959096
info@dolphin-marine.net

Estonia

VETUS Oy
Tel.: +358 207756740
info@vetus.fi

SERVICE & DISTRIBUTION NETWORK

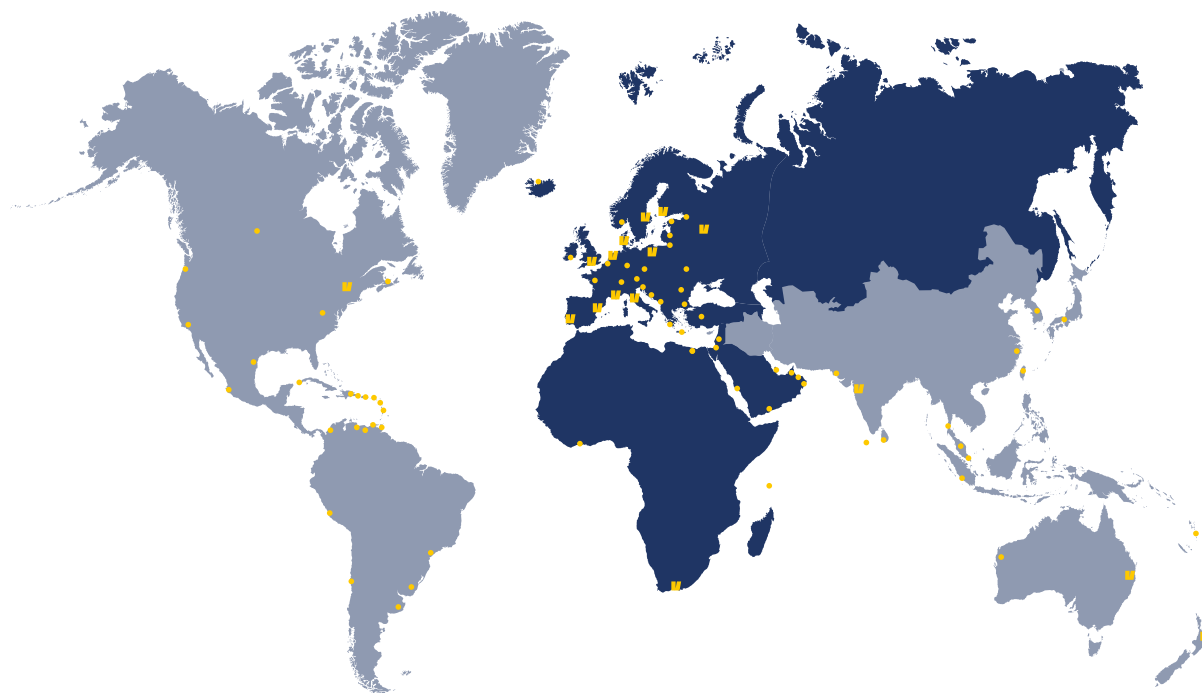

EMEA Europe, Middle East and Africa

Germany

Bukh-Bremen GmbH
Tel.: +49 421 535070
info@bukh-bremen.de

Gibraltar

M. Sheppard & Co Ltd
Tel.: +350 200 75148/77183
retail@sheppard.gi

Greece

VETUS Hellas Ltd.
Tel.: +30 210
4135 531 / 4133 639
info@vetus.gr

Hungary

Fuke Yacht Ltd.
Tel.: +36 88 432 897
info@fukeyacht.hu

Iceland

Baldur Halldorsson ehf.
Tel.: +354 462 37 00
b.h@mi.is

Ireland

Union Chandlery
Tel.: +353 21 4554 334
vetus@unionchandlery.com

Israel

Yamit YSB Ltd. Marine Trade Co.
Tel.: +972 3 527 1777
office@yamitysb.co.il

Ivory Coast

Divertech
divertech_ci@yahoo.fr

Jordan

see United Arab Emirates

Kuwait

VETUS
see United Arab Emirates

Maxwell

Al Sabih Marine Equipment
Company
Tel.: +965 24835228
alsabihmarine@yahoo.com

Latvia

VETUS Oy
Tel.: +358 207756740
info@vetus.lv

Lebanon

see United Arab Emirates

Lithuania

VETUS Oy
Tel.: +358 207756740
info@vetus.lt

Malta

Gauci Borda & Co. Ltd.
Tel.: +356 21 340 491
+356 21 313 758
myra@gauciborda.com

Norway

Univa A/S
Tel.: +47 37 06 20 50
jp@univa.no

Oman

see United Arab Emirates

Qatar

see United Arab Emirates

Romania

S.C. Technoind SRL
Tel.: +40 744 593 593
+40 236 415 442
puuu.maris@technoind.ro

Saudi Arabia

see United Arab Emirates

Seychelles

Adesho Marine
Power Marine
Tel.: +248 42 24 216
adesho@seychelles.net

Slovenia

Seawave Marine d.o.o.
Tel.: +386 45302 444
info@seawave-marine.si

Switzerland

VETUS AG Schweiz
Tel.: +41 26 660 7190/91
vetus@bluewin.ch

Turkey

VETUS
Marintek Deniz Ve Yat
Malzemeleri Ticaret A.S.
Tel.: +90 216 317 10 10
info@marintek.com.tr

Maxwell
DEKA Marin Deniz
Malzemeleri
Ticaret A.S.
Tel.: +90 444 11 75
info@dekamarine.com

Ukraine

Oriyana Shipyard
Tel.: +380 44 451 50 20
yacht@oriyana.com

United Arab. Emirates

Exalto Emirates LLC.
Tel.: +971 6545 3366
info@exalto-emirates.com

Yemen

see United Arab Emirates



UNIQUE 3 YEAR WARRANTY

VETUS equipment

VETUS offers an industry leading 3 year warranty on all equipment and a 5 year warranty on engines.

Your interests are the most important consideration for VETUS. We want you to enjoy life on the water and not be let down by technical failure. We want you to have confidence in your boat and the equipment on board. This is the starting point for the development of all new and existing VETUS products. Naturally quality, innovation, ease of use and ease of installation are equally important for every product developed.

Besides a world beating warranty, VETUS also provides a worldwide service network, so that our customers can always count on outstanding support.

UNIQUE 5 YEAR WARRANTY

VETUS engines

(Pleasure Craft Application)

For the first 36 months after the date of delivery to the first owner, all VETUS diesel propulsion engines are fully warranted in accordance with the conditions specified in the VETUS Owner's manual. For an additional period of 24 months thereafter, or 1000 additional operating hours whichever comes first, VETUS offers an extended limited warranty.



5+ EXTENDED WARRANTY

VETUS package deals

When a VETUS engine is purchased together with a complete VETUS around the Engine package, warranty will be extended from 3 to 5 years on the around the engine package. Together with the already very good warranty conditions on VETUS engines (3+2 years) VETUS products will ensure you to have a long and carefree use of your boat!

For more information check the VETUS warranty conditions on www.vetus.com or www.vetus.com/en/5-plus-warranty

ENGINES AND AROUND THE ENGINE

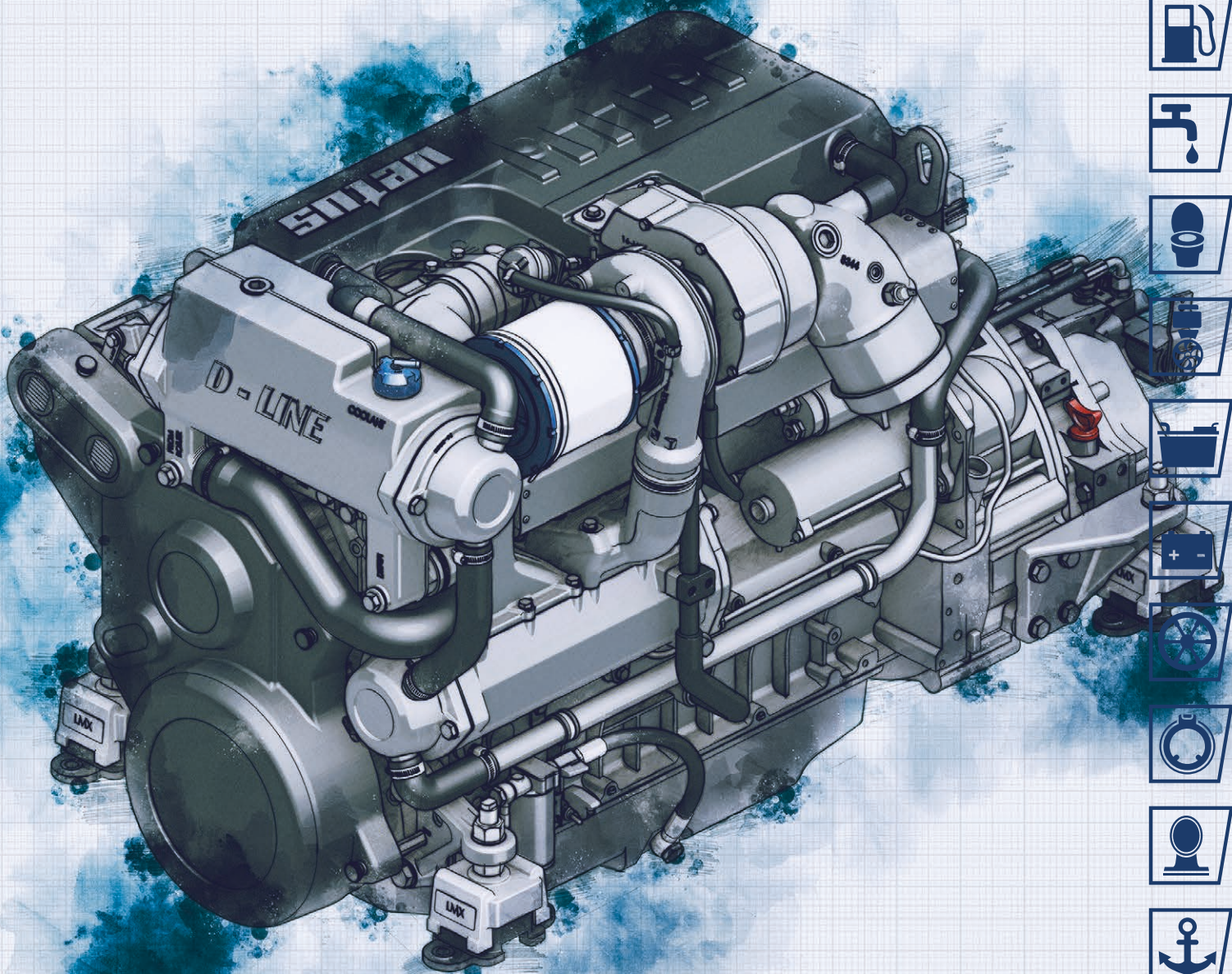

VETUS ENGINES

Marine Diesel Engines

Most pleasure boat owners long for the moment they can set foot aboard. Work is forgotten and other worries vanish into the air. That sense of happiness is complete, when the engine comes to life with a healthy roar. The owner of a power or sailing boat with a VETUS engine is in a position to enjoy every moment on the water to the max, and that is the way it should be! Whether you own a sturdy two cylinder with sail drive or a whispering six cylinder beauty, a VETUS Diesel Engine will be your faithful servant. To complement each marine engine in the range, VETUS also offers a well-thought-out complete package of "around the engine" products; from the engine remote control to the fuel filter to the propeller shaft to the exhaust system.

All VETUS engines are certified according ISO 8178-1.

M-LINE

VETUS offers a complete range of M-Line marine diesel engines, suitable for many different types of boats including launches, sailing yachts, canal boats and small cabin cruisers. Over the course of many years of steady development these engines have proven both their quality and reliability.



M2.13



M2.18



M3.29



M4.35



M4.45



M4.56

H-LINE

The H-Line engines are sturdy, reliable prime movers and are suitable for all kinds of applications, such as cabin boats, small fishing boats and larger canal boats. These engines have low noise and vibration levels due to their robust construction. They are also highly fuel efficient.

VETUS offers the VH4.65, 65hp at 3000 rpm and VH4.80 at 4000 rpm which both are naturally aspirated engines. The first model type VH4.65 meets the RCD2 regulations and the second type, VH4.80 is only available outside the European area at the moment and meets the RCD1 regulations.

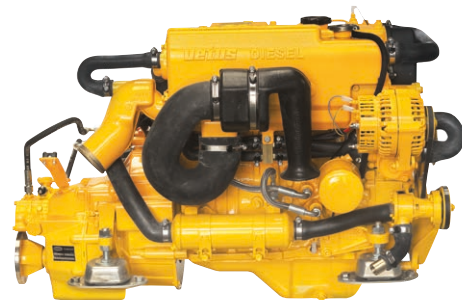

VH4.65

VH4.80

F-LINE

This new F-Line series of modern high-speed common-rail diesel engines is suitable for planing and semi-planing boats. They are compact, reliable, light weight and very fuel efficient. The power-to-weight ratio is excellent combined with high torque outputs. Due to the small overall dimensions, they are ideal for replacing existing petrol (gasoline) engines. Available with gearbox or sterndrive.



VF4.145
VF4.180
VF4.200

D-LINE

VETUS D-Line common-rail engines are ideal for heavy displacement boats. They are slow running and exceptionally smooth, making them the engine of choice where long distance cruising is involved. Based on the quality of the well-known Deutz engine blocks, they are exceptionally reliable and durable.

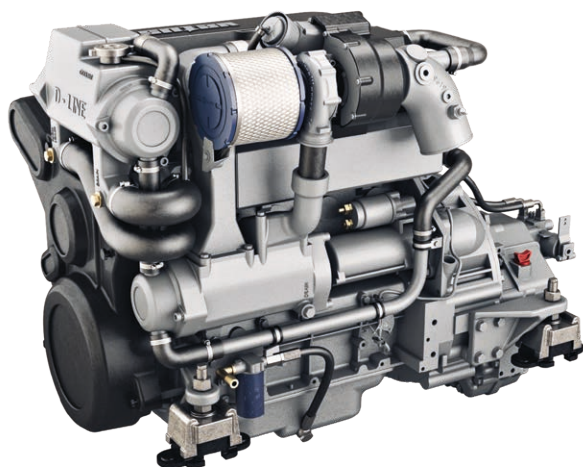

VD4.120
VD4.140

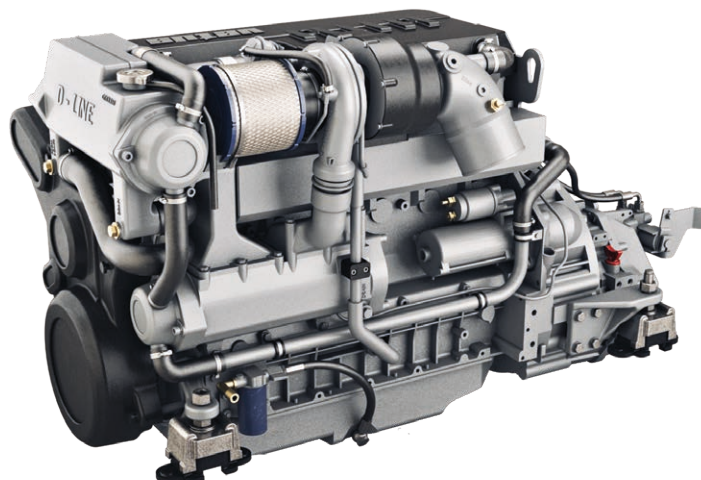

VD6.170
VD6.210



M-LINE

M-Line engines are quiet running, highly fuel-efficient, reliable and offer high power and torque output. The fuel systems are automatically self-bleeding, a great convenience after a fuel filter replacement. All engines are equipped with a high output marine alternator as standard for fast recharging of batteries. A second alternator is available as an option on all type M4 engines. And there is more....!



INNOVATION

Engine space temperature reduction

The heat build-up in engine spaces can easily reach temperatures of 158°F (70°C). High ambient temperatures in the engine space can have negative effects on engine performance and installed equipment.

VETUS has developed an elegant yet efficient solution by fitting a water-cooled aluminium top cover. Located directly above the cylinder head, this huge cooling element absorbs radiant heat coming from the engine. This innovative concept results in a significant temperature reduction of up to 59°F (15°C) - a 20% reduction! In turn, the cooler ambient temperature provides a more fuel-efficient air supply to the engine and better combustion. To the best of our knowledge, no other marine engine manufacturer uses such an incorporated cooling element to reduce ambient temperature in the engine space. A truly unique solution developed by VETUS.

Engine sound reduction

People often go boating to enjoy the peace and quiet of the water. VETUS likes to add to this experience by creating a propulsion system that performs as quietly as possible.

The sturdy, aluminium top cover also significantly reduces the noise level. When combined with the newly designed air filter housing, tests show a sound reduction of approximately 5 dB(A) and 'near silent' operation at a cruising speed of around 2200 rpm. Those present at the test sites have all enthusiastically described the engine sound as being incredibly more pleasant to the ear.

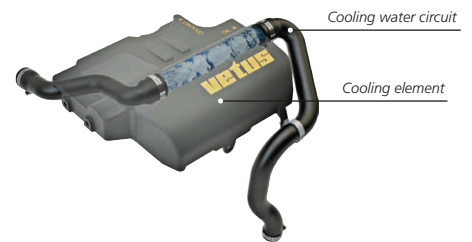

FEATURES

Based on customer feedback, the M-Line incorporates many features designed to make life easier for both the boat builder and the end user.

- Service parts such as fuses and relays (A), fuel filter and fuel connections (B), impeller (C), dipstick (D), and oil filter (E) are all easily accessible. On all M4 engines the impeller is located at the front, for even easier access
- The wiring is improved to offer easy connection and extra safety
- All M-Line engines are equipped with an electric fuel pump (F), actuated by the ignition switch
- A new air inlet filter housing attenuates the airflow and lowers the induction sound level (G)
- The heat exchanger unit has 26 improvements over earlier versions, including the construction materials and surface treatments
- The plastic front cover enhances safety and appearance. All pulleys and belts are covered, thereby meeting the EC Machinery Directive
- Front mounted oil and fuel filters including a bracket are available as an option, making servicing as convenient as possible (H)
- When higher charging output is required, all M4 engines are designed to accept a second alternator as an option (when a second alternator is fitted, the front cover is not supplied)
- All M4 engines can also be supplied as a power pack or hydraulic propulsion, see page 27
- Furthermore, all M-Line engines can be supplied with an adaptor kit for Volvo Penta saildrives (110S/120S and 120SB)
- The oil sump pump on all M-Line engines is already installed on the engine for easy maintenance
- Finally yet importantly, the water-cooled top cover not only reduces engine room temperature, but is designed to be used as a step, making it easier to move around or over the engine (I)

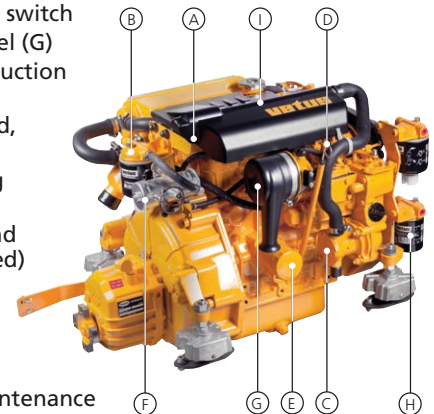

All these new advantages come without compromising any other features. With a range from 12 - 52 HP (9 - 37.5 kW) the VETUS M-Line is the preferred choice for many boat builders. Do you need more reasons to choose a VETUS engine?

Customers can expect the highest level of service when choosing a VETUS engine, together with high quality and professional advice.

All M-Line engines meet the RCD2 emission standards and some also meet the BSOII regulations.

SOLAS

For our SOLAS solutions see page 40.

M-LINE

M2.13

● ● 8.8 kW / 12 HP

TECHNICAL SPECIFICATIONS

Supplied as standard with instrument panel type MP10B12 (see page 107), four flexible engine mounts type KSTEUN25V (see page 50) and a pre-installed oil sump pump.



Engine model	M2.13
Max. output at flywheel (ISO 8665)	8.8 kW (12 hp)
Max. output at propeller shaft (ISO 8665)	8.7 kW (11.8 hp)
Maximum rpm	3000
Max. torque	32.7 Nm / 1600 rpm
Bore x stroke	3" x 2.8" (76 mm x 70 mm)
Displacement	39 cu.inch (635 cm ³)
Number of cylinders	2 in line
Combustion system	indirect injection
Compression ratio	23:1
Firing order	1-2
Intake	naturally aspirated
Electrical system	12 Volt - 75 Amps.
Cooling system (standard)	indirect cooling (keel cooling optional)
Gearbox, standard	TMC40P (2 / 2.60:1)
Gearbox options	ZF12M 2.14 / 2.63:1 ZF15MIV 2.13 / 2.99:1 TMC60A 2 / 2.5:1

Saildrive	SP60 2.15 / 2.38:1 SD10 2.23 / 2.49:1
Dry weight (incl. std. gearbox)	236 lbs (107 kg)
Fuel consumption at 2500 rpm	268 g / kW.h (196 g / hp.h)
Max. backwards installation angle	15°
Max. lateral inclination angle;	
Continuously	25°
5 minutes max.	30°
Suction height of fuel lift pump	5 ft. (1.5 m)
Calorifier connection kit	optional
Instrument panel (standard)	MP10B12
Warning lights and audible alarm	oil pressure, temperature (coolant and exhaust), charging current
Control light for	pre-heating/glow plugs
Electric circuit protection	fuse 10 Amps.
Certifications	EU-RCD II, BSO II

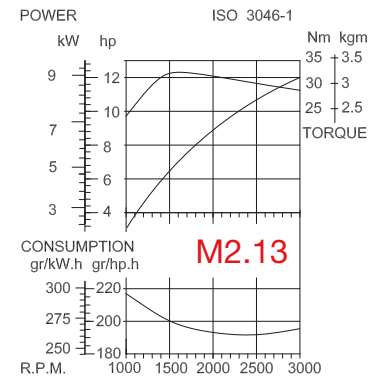
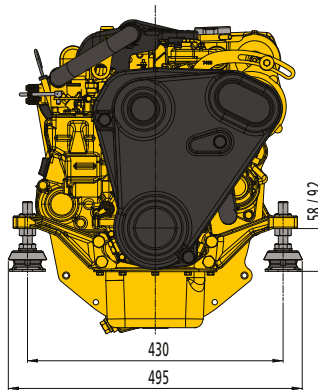
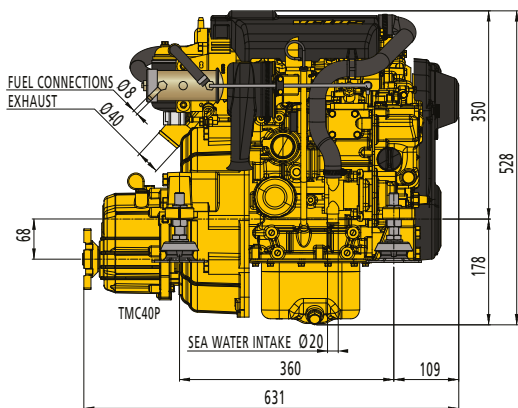

Certified within 5%

M-LINE

M2.18

● ● 11.8 kW / 16 HP

TECHNICAL SPECIFICATIONS

Supplied as standard with instrument panel type MP10B12 (see page 107), four flexible engine mounts type KSTEUN35V (see page 50) and a pre-installed oil sump pump.



Engine model	M2.18
Max. output at flywheel (ISO 8665)	11.8 kW (16 hp)
Max. output at propeller shaft (ISO 8665)	11.6 kW (15.8 hp)
Maximum rpm	3600
Max. torque	35.1 Nm / 2000 rpm
Bore x stroke	3" x 2.8" (76 mm x 70 mm)
Displacement	39 cu.inch (635 cm ³)
Number of cylinders	2 in line
Combustion system	indirect injection
Compression ratio	23:1
Firing order	1-2
Intake	naturally aspirated
Electrical system	12 Volt - 75 Amps.
Cooling system (standard)	indirect cooling (keel cooling optional)
Gearbox, standard	TMC40P (2 / 2.60:1)
Gearbox options	ZF12M 2.14 / 2.63:1 ZF15MIV 2.13 / 2.99:1 TMC60A 2 / 2.5:1

Saildrive	SP60 2.15 / 2.38:1 SD10 2.23 / 2.49:1
Dry weight (incl. std. gearbox)	236 lbs (107 kg)
Fuel consumption at 2500 rpm	268 g / kW.h (196 g / hp.h)
Max. backwards installation angle	15°
Max. lateral inclination angle;	
Continuously	25°
5 minutes max.	30°
Suction height of fuel lift pump	5 ft. (1.5 m)
Calorifier connection kit	optional
Instrument panel (standard)	MP10B12
Warning lights and audible alarm	oil pressure, temperature (coolant and exhaust), charging current
Control light for	pre-heating/glow plugs
Electric circuit protection	fuse 10 Amps.
Certifications	EU-RCD II, BSO II

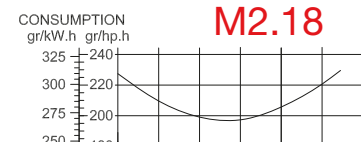
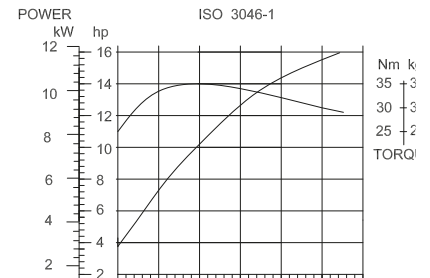
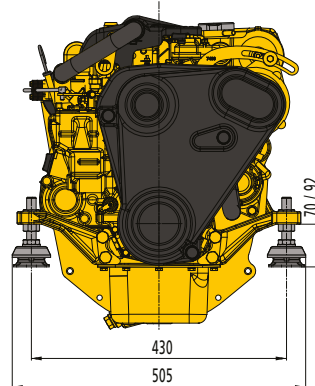
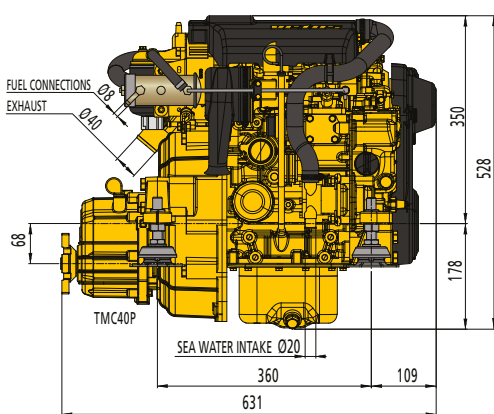

Certified within 5%

M-LINE

M3.29

● ● ● 20 kW / 27 HP

TECHNICAL SPECIFICATIONS

Supplied as standard with instrument panel type MPA22KBS2 (see page 105), four flexible engine mounts type KSTEUN40A (see page 50) and a pre-installed oil sump pump.



Engine model	M3.29
Max. output at flywheel (ISO 8665)	20 kW (27 hp)
Max. output at propeller shaft (ISO 8665)	19.3 kW (26.2 hp)
Maximum rpm	3600
Max. torque	60.2 Nm / 2500 rpm
Bore x stroke	3" x 2.8" (76 mm x 70 mm)
Displacement	58 cu.inch (952 cm ³)
Number of cylinders	3 in line
Combustion system	indirect injection
Compression ratio	22:1
Firing order	1-3-2
Intake	naturally aspirated
Electrical system	12 Volt - 75 Amps.
Cooling system (standard)	indirect cooling (keel cooling optional)
Gearbox, standard	TMC40P (2 / 2.60:1)
Gearbox options	ZF12M 2.14 / 2.63:1 ZF15MIV 2.13 / 2.99:1 TMC60A 2 / 2.5:1

Saildrive	SP60 2.15 / 2.38:1 SD10 2.23 / 2.49:1
Dry weight (incl. std. gearbox)	295 lbs (134 kg)
Fuel consumption at 2500 rpm	270 g / kW.h (199 g / hp.h)
Max. backwards installation angle	15°
Max. lateral inclination angle;	
Continuously	25°
5 minutes max.	30°
Suction height of fuel lift pump	5 ft. (1.5 m)
Calorifier connection kit	optional
Instrument panel (standard)	MPA22KBS2
Warning lights and audible alarm	oil pressure, temperature (coolant and exhaust), charging current
Control light for	pre-heating/glow plugs
Electric circuit protection	fuse 10 Amps.
Certifications	EU-RCd II, BSO II, SOLAS

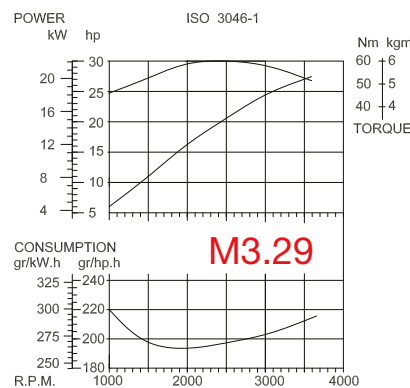
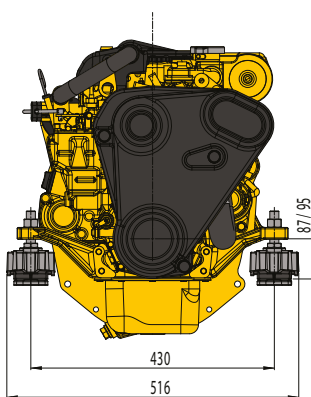
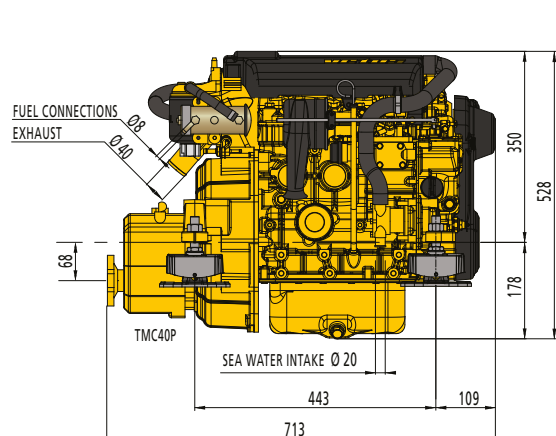

Certified within 5%

M-LINE

M4.35

● ● ● ● 24.3 kW / 33 HP

TECHNICAL SPECIFICATIONS

Supplied as standard with instrument panel type MPA22KBS2 (see page 105), four flexible engine mounts type KSTEUN75V (see page 50) and a pre-installed oil sump pump.



Engine model	M4.35
Max. output at flywheel (ISO 8665)	24.3 kW (33 hp)
Max. output at propeller shaft (ISO 8665)	23.6 kW (32.1 hp)
Maximum rpm	3000
Max. torque	83.8 Nm/1700 rpm
Bore x stroke	3.07" x 3.62" (78 mm x 92 mm)
Displacement	108 cu.inch (1758 cm ³)
Number of cylinders	4 in line
Combustion system	indirect injection
Compression ratio	22:1
Firing order	1-3-4-2
Intake	naturally aspirated
Electrical system	12 Volt - 110 Amps.
Cooling system (standard)	indirect cooling (keel cooling optional)
Gearbox, standard	TMC60P (2 / 2.5 / 2.94:1)
Gearbox options	ZF12M 2.14 / 2.63:1 TMC60A 2 / 2.5:1

Saildrive	SP60 2.15 / 2.38:1 SD10 2.23 / 2.49:1
Dry weight (incl. std. gearbox)	439 lbs (199 kg)
Fuel consumption at 2500 rpm	252 g / kW.h (185 g / hp.h)
Max. backwards installation angle	15°
Max. lateral inclination angle;	
Continuously	25°
5 minutes max.	30°
Suction height of fuel lift pump	5 ft (1.5 m)
Calorifier connection kit	optional
Instrument panel (standard)	MPA22KBS2
Warning lights and audible alarm	oil pressure, temperature (coolant and exhaust), charging current
Control light for	pre-heating/glow plugs
Electric circuit protection	fuse 10 Amps.
Certifications	EU-RCD II, BSO II, SOLAS

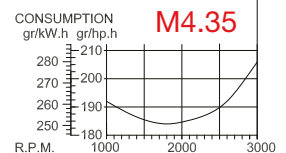
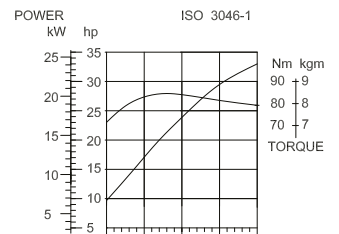
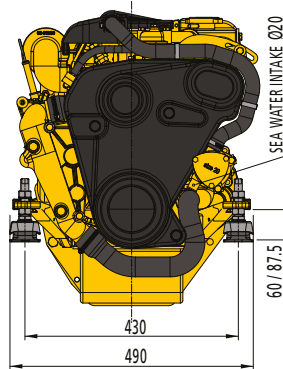
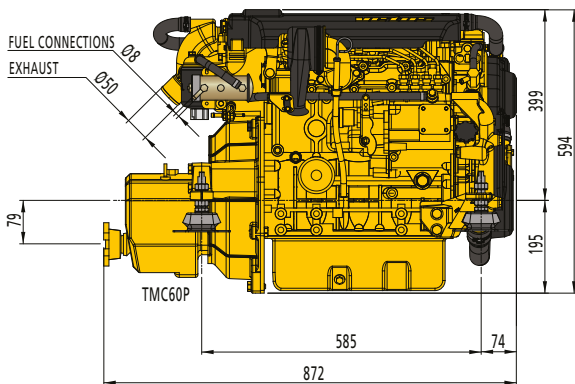

Certified within 5%

M-LINE

M4.45

● ● ● ● 30.9 kW / 42 HP

TECHNICAL SPECIFICATIONS

Supplied as standard with instrument panel type MPA22KBS2 (see page 105), four flexible engine mounts type KSTEUN75V (see page 50) and a pre-installed oil sump pump.



Engine model	M4.45
Max. output at flywheel (ISO 8665)	30.9 kW (42 hp)
Max. output at propeller shaft (ISO 8665)	30 kW (40.8 hp)
Maximum rpm	3000
Max. torque	106.4 Nm / 1750 rpm
Bore x stroke	3.07" x 3.62" (78 mm x 92 mm)
Displacement	108 cu.inch (1758 cm ³)
Number of cylinders	4 in line
Combustion system	indirect injection
Compression ratio	22:1
Firing order	1-3-4-2
Intake	naturally aspirated
Electrical system	12 Volt - 110 Amps.
Cooling system (standard)	indirect cooling (keel cooling optional)
Gearbox, standard	TMC60P (2 / 2.5 / 2.94:1)
Gearbox options	ZF12M 2.14 / 2.63:1 TMC60A 2 / 2.5:1

Saildrive	SP60 2.15 / 2.38:1 SD10 2.23 / 2.49:1
Dry weight (incl. std. gearbox)	439 lbs (199 kg)
Fuel consumption at 2500 rpm	252 g / kW.h (185 g / hp.h)
Max. backwards installation angle	15°
Max. lateral inclination angle;	
Continuously	25°
5 minutes max.	30°
Suction height of fuel lift pump	5 ft. (1.5 m)
Calorifier connection kit	optional
Instrument panel (standard)	MPA22KBS2
Warning lights and audible alarm	oil pressure, temperature and (coolant exhaust), charging current
Control light for	pre-heating/glow plugs
Electric circuit protection	fuse 10 Amps.
Certifications	EU-RCD II, BSO II, SOLAS

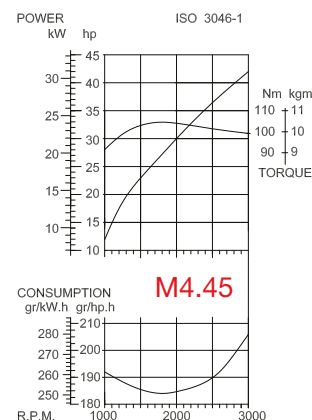
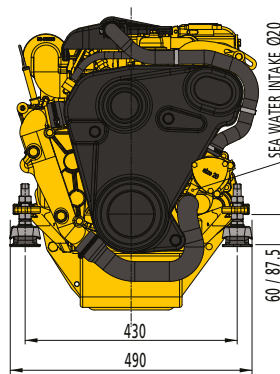
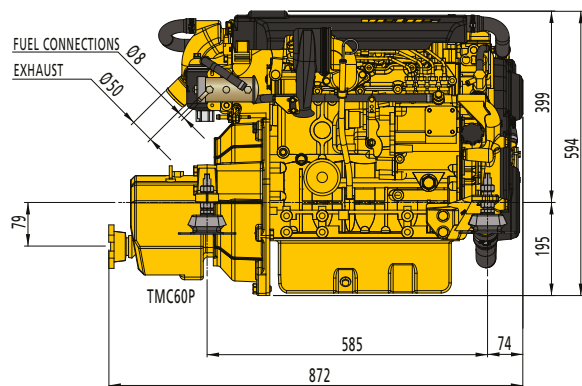

Certified within 5%

M-LINE

M4.56

● ● ● ● 38.3 kW / 52 HP

TECHNICAL SPECIFICATIONS

Supplied as standard with instrument panel type MPA22KBS2 (see page 105), four flexible engine mounts type KSTEUN80V (see page 50) and a pre-installed oil sump pump.

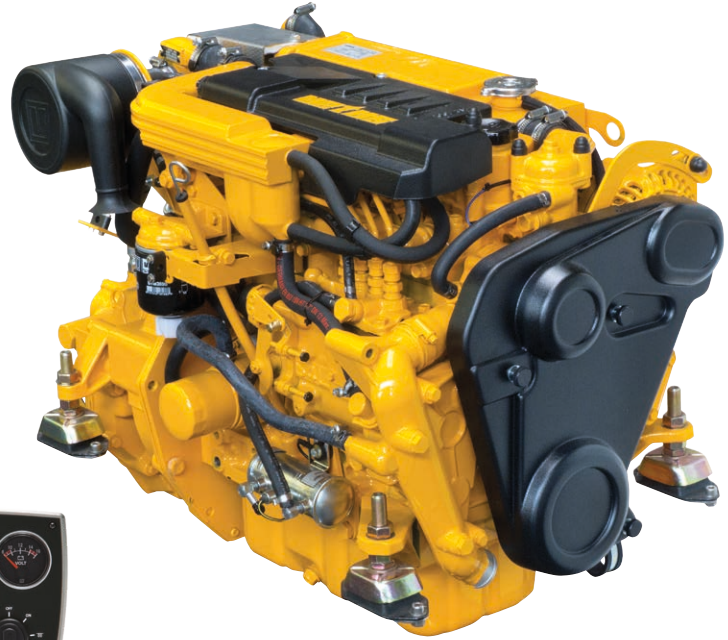

Engine model	M4.56
Max. output at flywheel (ISO 8665)	38.3 kW (52 hp)
Max. output at propeller shaft (ISO 8665)	37.1 kW (51 hp)
Maximum rpm	3000
Max. torque	127 Nm / 2000 rpm
Bore x stroke	3.07" x 3.62" (78 mm x 92 mm)
Displacement	108 cu.inch (1758 cm ³)
Number of cylinders	4 in line
Combustion system	indirect injection
Compression ratio	22:1
Firing order	1-3-4-2
Intake	Turbo charged
Electrical system	12 Volt - 110 Amps.
Cooling system (standard)	indirect cooling (keel cooling optional)
Gearbox, standard	TM345(A) (2 / 2.47:1)
Gearbox options	ZF12M 2.14:1
	ZF15MIV 2.13 / 2.99:1
	TMC60P 2 / 2.5:1

Saildrive	SP60 2.15 / 2.38:1 SD10 2.23 / 2.49:1
Dry weight (incl. std. gearbox)	454 lbs (206 kg)
Fuel consumption at 2500 rpm	244 g / kW.h (179 g / hp.h)
Max. backwards installation angle	15°
Max. lateral inclination angle;	Continuously 25°
	5 minutes max. 30°
Suction height of fuel lift pump	5 ft. (1.5 m)
Calorifier connection kit	optional
Instrument panel (standard)	MPA22KBS2
Warning lights and audible alarm	oil pressure, temperature (coolant and exhaust), charging current
	Control light for pre-heating/glow plugs
Electric circuit protection	fuse 10 Amps.
Certifications	EU-RCD II, SOLAS

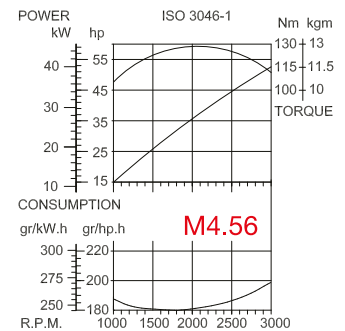
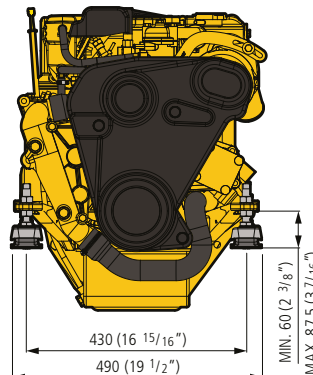
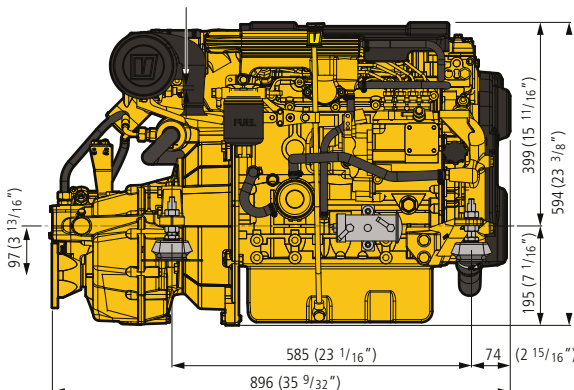

Certified within 5%

H-LINE

The H-Line engines are sturdy, reliable engines and are suitable for many applications, such as cabin boats, small fishing boats and larger canal boats. These engines have low noise and vibration levels due to their robust construction. They are also highly fuel efficient.

The H-Line engines are four-cylinder 4-stroke engines with an indirect fuel injection system, a dual-circuit cooling system with integrated heat exchanger and a seawater injected exhaust bend.

Available in two versions: VH4.65 and VH4.80.

A few advantages of these engines

- Extremely favourable power to weight ratio
- Very low noise and vibration levels due to counter balancing shafts
- Very low fuel consumption
- Minimum hose connections, owing to extensive use of molded rubber cooling system components
- High alternator output as standard, developed for marine applications for fast recharging of the batteries
- Self-bleeding fuel system
- Readily accessible parts for easy maintenance

Suitable for

- Cabin boats
- Sailing boats
- Small fishing boats
- Larger canal boats

Options

- The H-Line engines can be supplied with gearbox or saildrive
- Alternatively, the H-Line can be supplied with an adaptor kit to fit an existing Volvo Penta saildrive, type 110S, 120S or 120SB
- Available as a power pack complete with hydraulic pump, when hydraulic power is needed for auxiliary components on board (see page 28)

Purchasing a VETUS H-Line engine brings a host of related benefits

- The extensive VETUS dealer network is on hand to provide service, spare parts and points of contact worldwide
- A VETUS engine brings with it over 50 years of experience in producing reliable and compact marine engines, ensuring safe and continuous boating pleasure
- All VETUS engines come with a 5 year warranty in accordance with the VETUS Warranty and Service Conditions

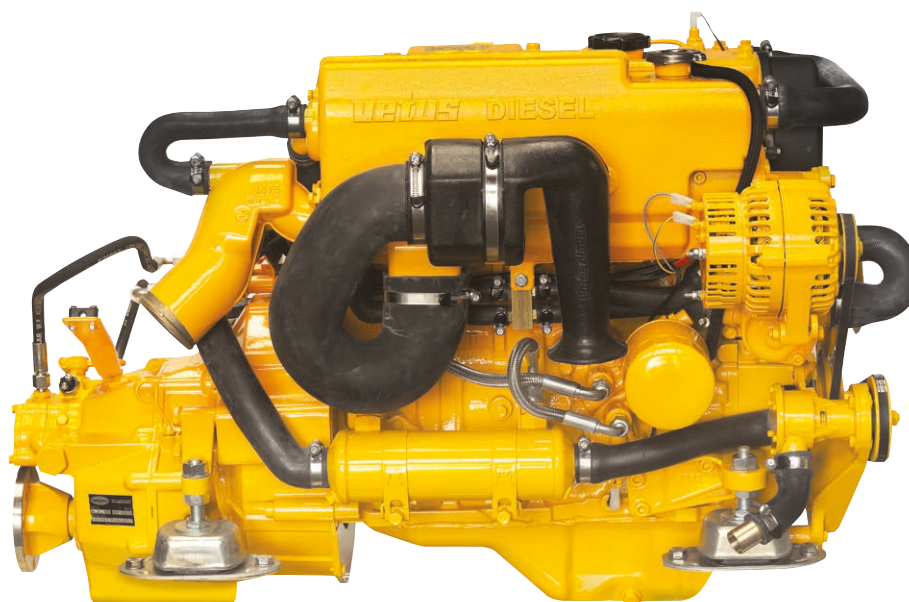

H-LINE

VH4.65

● ● ● ● 48 kW / 65.3 HP

VH4.80^{*)}

● ● ● ● 59 kW / 80.3 HP

*) Available outside the EU, RCD2 pending

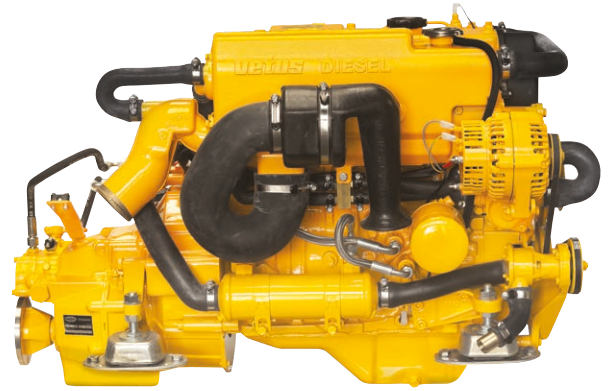

TECHNICAL SPECIFICATIONS

Supplied as standard with instrument panel type MPA22KBS2 / BS25 (see page 105), four flexible engine mounts type HY100 (see page 51) and an oil sump pump.

Engine model	VH4.65 / VH4.80	
*Max. output at flywheel (ISO 3046-1)	48 kW (65.3 hp) (VH4.65)	59 kW (80.3 hp) (VH4.80)
*Max. output at propeller shaft (ISO 3046-1)	46.6 kW (63.4 hp) (VH4.65)	57.2 kW (77.6 hp) (VH4.80)
Maximum rpm	3000 (VH4.65) / 4000 (VH4.80)	
Bore x stroke	3.58" x 3.94" (91.1 mm x 100 mm)	
Displacement	159 cu.inch (2607 cm ³)	
Number of cylinders	4 in line	
Combustion system	indirect injection	
Compression ratio	22:1	
Firing order	1-3-4-2	
Intake	Naturally aspirated	
Electrical system	12 Volt - 115 Amps.	
Cooling system (standard)	indirect cooling (keel cooling optional)	
Gearbox (standard)	TM345(A)	
Ratio	2 / 2.47:1	
Gearbox options	ZF25A 1.93 / 2.29 / 2.71:1 ZF25 1.97 / 2.8:1	
Saildrive	SP60 2.15:1 SD10 2.23:1	
Dry weight (incl. std. gearbox)	528 lbs (240 kg) (VH4.65)	539 lbs (245 kg) (VH4.80)
Fuel consumption at 2500 rpm	260 g / kW.h (190 g / hp.h)	
Max. torque	170 Nm / 2.200 rpm	
Max. backwards installation angle	15°	
Max. lateral inclination angle;	Continuously	25°
	5 minutes max.	30°
Suction height of fuel lift pump	5 ft. (1.5 m)	
Calorifier connection kit	optional	
Instrument panel (standard)	MPA22KBS2 / BS25	
Warning lights and audible alarm	oil pressure, temperature (coolant and exhaust), charging current	
Control light for	pre-heating	
Electric circuit protection	fuse 10 Amps.	
Certifications	EU-RCD II (VH4.65) EU-RCDI, RCDII pending (VH4.80) RRR emission standards (VH4.65/VH4.80)	

* In accordance with ISO 8665

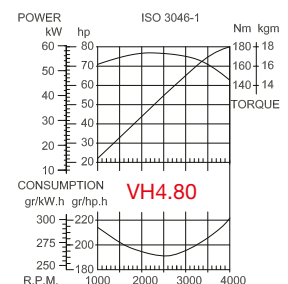
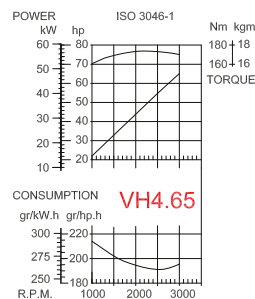
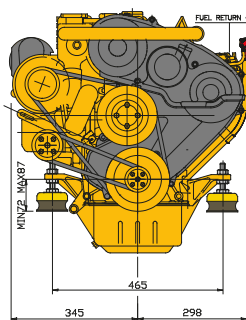
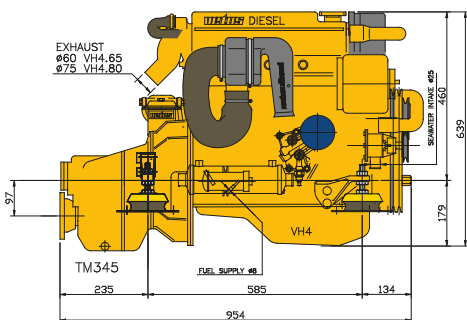

Certified within 5%

EQUIPMENT SELECTION TABLE FOR M-LINE AND H-LINE



COMFL

See flexible couplings on page 66



See fuel filters on page 123

See propellers on page 78



FTR470

See water strainers on page 53



SISCO

See remote controls on page 44



NLP40

See waterlocks on page 88 and 92



NLP40HD

Engine model	M2.13		M2.18		M3.29		M4.35		M4.45		M4.56		VH4.65		VH4.80			
Gearbox reduction	2:1	2.6:1	2:1	2.6:1	2:1	2.6:1	2:1	2.5:1	2:1	2.5:1	2:1	2,47:1	2:1	2.63:1	1.97:1	2.8:1		
VETUS water lubricated propeller shaft system																		
* Shaft diam., Remanit 4462	25				30				35		30		35		30		40	
VETUS manganese bronze propeller for displacement boats																		
* 3-blade, P3B, diameter in inches	13"	15"	13"	15"	14"	16"	18"	20"	18"	20"	17"	21"	request	22"				
* 4-blade, P4E, diameter in inches	on request																	
Flexfold NiAlBz folding propellers for sailing boats can exclusively be purchased through the Flexofold network (look at: www.flexofold.com)																		
2-blade, FoF folding propeller	13"	15"	13"	15"	15"	n.a.												
3-blade, FoF folding propeller	n.a.				15"	16"	17"	17"	18"	18"	20"	18"	20"	request	20"			
4-blade, FoF folding propeller	on request																	
VETUS flexible couplings																		
* Bullflex type	01		02		04		08		04		08		04		08			
* Uniflex type					13		16		13				16					
* Combiflex type					12		n.a.		12				n.a.					
VETUS water strainer																		
* hose connection diam. inches (mm)					²⁵ / ₃₂ " (20)								1" (25)					
* water strainer, type FTR470, FTR330 or CWS:					330 or 470/19								330 or 470/25 / CWS1					
* water strainer kit, type					WKIT33019								WKIT33025					
VETUS water separator / fuel filter																		
* hose connection suction/return in inches (mm)							⁵ / ₁₆ "(8) - ⁵ / ₁₆ "(8)											
* water separator / fuel filter, type:							(75)330VTEB or WS180											
VETUS water-injected exhaust systems																		
* exhaust hose, diam. inches (mm)	1 ⁹ / ₁₆ " (40)				2" (50)				2 ³ / ₈ " (60)				3" (75)					
* waterlock, type	NLP(3)40/LP40 NLP40HD				NLP(3)50/L50R/S NLP50HD				NLP(3)60/LP60 NLP60HD				NLP(3)75/LP75 NLP75HD					
* combi waterlock/muffler, type	NLP40				NLP50				n.a.				n.a.					
* muffler, type	MP40				MP50				MP60		MP60		MP75					
* gooseneck, type	LT40				LT50				LT60		LT60		LT75					
* combi muffler/gooseneck, type	NLP40				NLP50				n.a.		n.a.		n.a.					
* transom exhaust connection, type TRC	40R / PV or SV				50R / PV or SV				60R / PV or SV				TRC7590R					
* anti-siphon, type AIRVENT or ASD	V or H																	
VETUS engine remote controls																		
* to be selected	SICO, SISCO, AFSTZIJ, RCTOPB, RCTOPS, AFSTTOP																	
VETUS maintenance free batteries																		
* voltage									12									
* starter battery, min. Ah	55								108									
* service battery, Ah.	to be selected																	
VETUS louvered air suction vents																		
* per engine, type ASV, SSV or SSVL	1 x 25	2 x 20	2 x 25	2 x 40 or 4 x 20	2 x 50 or 4 x 30	2 x 60 or 4 x 30/ 3 x 40	2 x 70 or 2 x 30 + 2 x 40	2 x 80 or 4 x 40										

OPTIONS FOR M-LINE AND H-LINE

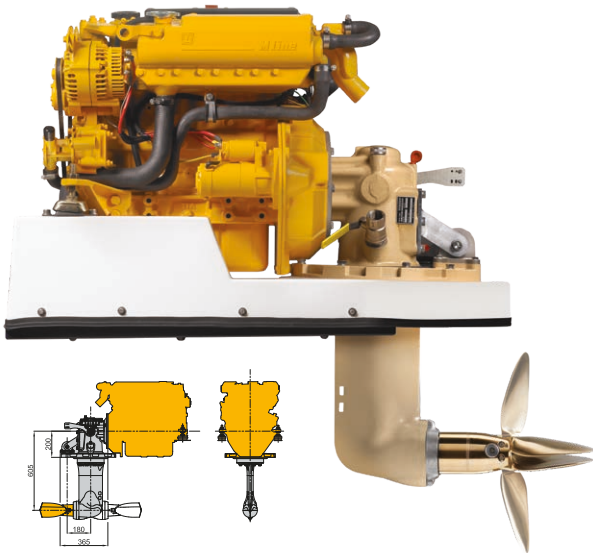

Saildrive

VETUS can supply a saildrive for all M-Line and H-Line engines. There are two different types available which are the Technodrive SP60, ratios 2.15:1 or 2.38:1 and the ZF SD10, ratios 2.23:1 or 2.49:1. They can be used for both single and twin engine installations.

The underwater drive leg can be fitted 180° reversed. This will permit the engine to be installed ahead or behind the saildrive unit for greater flexibility of installation.

We will be pleased to recommend the correct Flexofold propeller for your saildrive.



Filters

Front mounted oil and fuel filters including a bracket are available as an option on the M-Line range, making servicing as convenient as possible.

Code	Engine type
08-01454	M2
08-01455	M3
08-01479	M4
08-01456	M2 + electric fuel pump
08-01457	M3 + electric fuel pump

Saildrive kits

All VETUS M-Line engines and model VH4.65 can be supplied with an adapter kit to fit an existing Volvo Penta sail drive. Kits are available for 110S, 120S or 120SB saildrives.

Code	Saildrive
STM7614	110S
STM7619	120S
STM7621	120SB

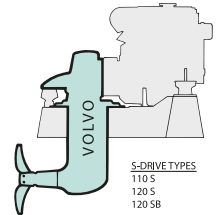

Second alternator

Engine models M4.35, M4.45 and M4.56 can be supplied with a second alternator of 110 A. When this option is specified, the front belt cover is not fitted. For other M series engines a second alternator of 75 A can be ordered.

Please contact your local VETUS dealer for more information.

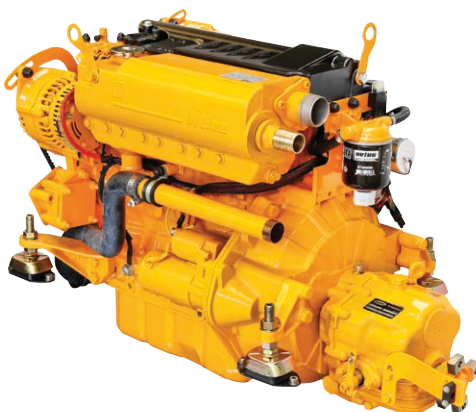

Keelcooling

M-Line and H-Line models are also available as keelcooled versions. Keelcooling systems are normally installed when the boat is used in shallow waters.

Please ask your dealer for details.

HYDRAULIC PROPULSION

In many cases it may be preferable to drive the propeller shaft by means of a hydraulic motor, instead of using the conventional set up of engine and gearbox.

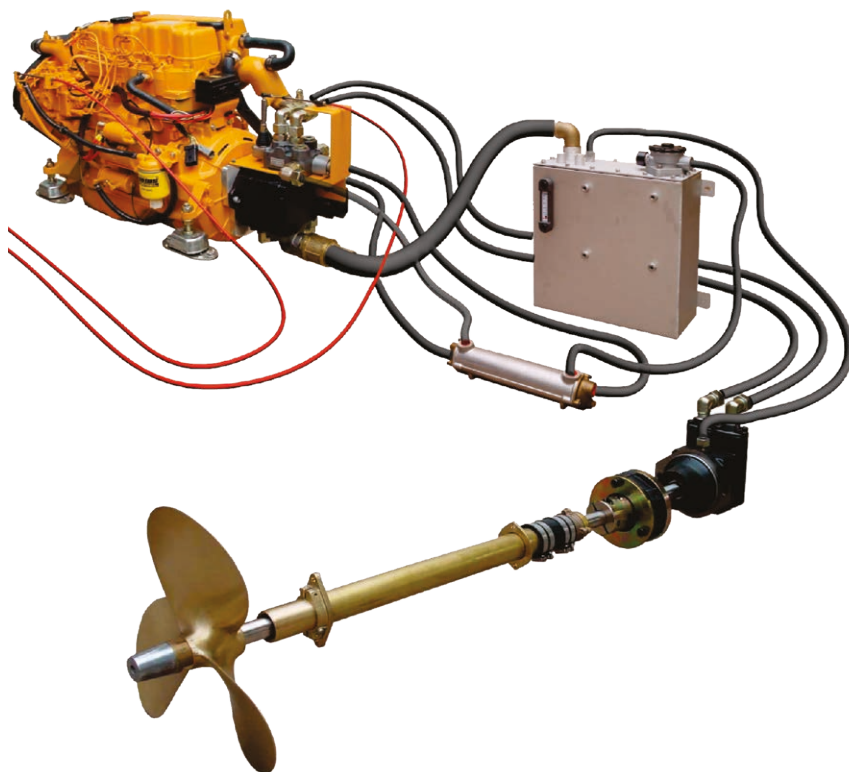

How it works

A hydraulic vane pump is fitted to the engine in place of the gearbox. This pump draws hydraulic fluid from a storage tank and delivers it under pressure to the speed and direction control valve. The control valve determines the direction and volume of hydraulic flow to the hydraulic vane motor, which can then rotate clockwise or counter clockwise as selected. This hydraulic motor drives the propeller shaft via a flexible coupling.

The VETUS system uses a hydraulic pump and motor with fixed swept volumes. The transmission ratios (reduction) in the propulsion system are achieved by the difference in volume between the vane pump and the hydraulic motor.

The reduction between the engine RPM and the shaft RPM is 2:1 for models HPM4.35, HPM4.45 and HPM4.56 and 1.9:1 for model HPH4.65. The maximum permissible engine power is 50 kW (67 HP), with a maximum engine speed of 3,000 RPM. In most cases a shaft diameter \varnothing 1" (25 mm) will suffice. The output flange of the VETUS hydraulic motor fits all VETUS flexible couplings.

Scope of supply

VETUS hydraulic propulsion is available in 4 versions:

Model HPM4.35 has a VETUS M4.35 marine diesel engine of 24.3 kW (33 hp).

Model HPM4.45 has a VETUS M4.45 marine diesel engine of 30.9 kW (42 hp).

Model HPM4.56 has a VETUS M4.56 marine diesel engine of 38 kW (52 hp).

Model HPH4.65 has a VETUS VH4.65 marine diesel engine of 48 kW (65 hp).

VETUS hydraulic vane motor



Stainless steel storage tank



VETUS hydraulic vane pump



All versions include

- Hydraulic vane pump
- Adapter flange and coupling to fit the pump to the relevant engine
- Hydraulic vane motor
- 35 litre hydraulic oil tank
- Oil cooler
- Control valve
- Flexible engine mounts
- Engine instrument panel and loom

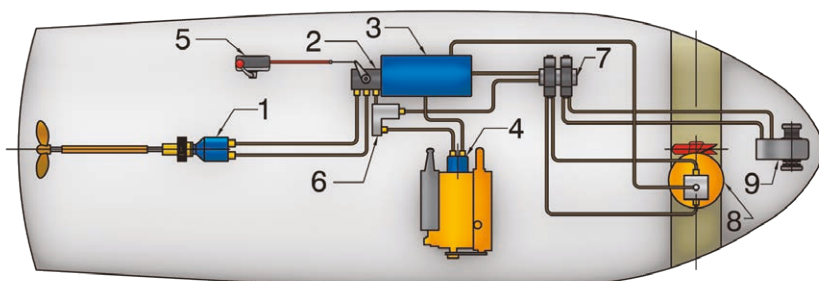

1. Hydraulic vane motor
2. Mechanically operated control valve
3. Stainless steel storage tank
4. Hydraulic vane pump
5. Remote control handle with cable
6. Connection for ancillary devices
7. Control unit for ancillary devices
8. Bow thruster
9. Anchor windlass

POWERPACK

Hydraulic powerpack

A stand-alone diesel engine with a hydraulic pump, dedicated to driving a hydraulic system

Although most hydraulic systems will use the propulsion engines or genset engine as the prime mover, there are some circumstances where a powerpack is necessary or more economical to operate, including:

- When adequate power for hydraulic applications is not available from propulsion or genset engines
- When running large propulsion engines or genset engines to power relatively small hydraulic power needs consumes excessive quantities of fuel, is uneconomical and over time, damaging to the propulsion or genset engines through under-loading
- When station holding can be accomplished by thrusters only without running main propulsion engines
- On some towed workboats and barges which do not have propulsion engines but which can be maneuvered around a worksite on thrusters only
- When some functions conventionally powered by electricity can be driven hydraulically, substantially reducing genset size
- When propulsion transmission is completely hydraulic, as in some single engine catamarans
- When a hydraulically driven "pony" shaft and feathering propeller is installed in the hull as a "get-you-home" drive to save the day in the event of main engine failure. (This concept is also particularly useful (and comforting) on single engine trawlers and similar vessels equipped with PTO fitted gensets.)

Typically a VETUS powerpack will consist of an M or VH series diesel engine with an appropriately sized hydraulic pump (variable volume, load-sensing or vane type depending upon the application) mounted on an adaptor plate in place of a gearbox. VETUS diesel engines meet all European emission requirements but at the time of publication of this catalogue are not EPA certified for use in the USA or Canada. If the powerpack is entirely devoted to propulsion, then its diesel engine will be controlled by a throttle lever, but in a multiple user-device system with a load sensing pump an electronic control will be fitted to the powerpack engine.

As with all VETUS hydraulic systems, a customer support engineer will work with you to configure the powerpack and related systems to suit your vessel and its needs.

There are three VETUS powerpack models available:

PPM435
PPM445
PPH465

Model	Power engine	Max rpm	Hydr. pump
PPM435	33 HP	3000	30 cm ³ / rpm
PPM445	42 HP	3000	30 cm ³ / rpm
PPH465	65 HP	3000	30 cm ³ / rpm

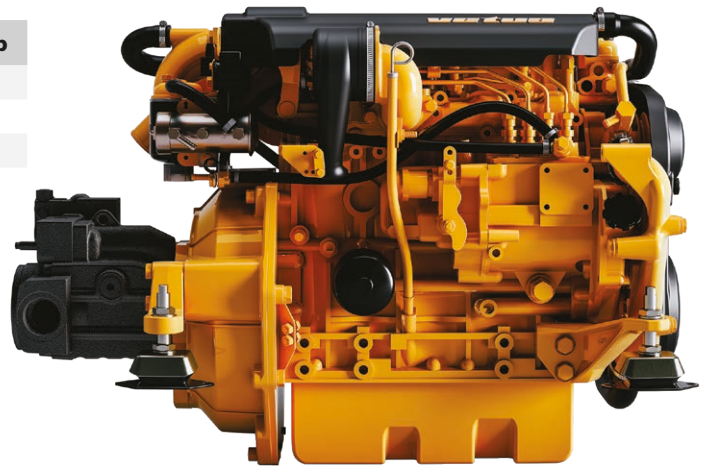

ACCESSORIES INCLUDED AS STANDARD WITH A VETUS POWERPACK



Four flexible engine mounts.



Engine instrument panel type MPA22KBS2. Including 4 m cable. A flybridge panel is available as an option.

F-LINE

Next generation F-Line 4-cylinder engines

VETUS proudly presents the new generation of high performance common-rail diesel engines with variable geometry turbocharging, which is especially designed for installation in fast semi-planing and planing boats. These marine engines are compact, lightweight, fuel efficient and have an excellent power-to-weight ratio. The new range covers three different models; VF4.145, VF4.180 and VF4.200 which are supplied with a SAEJ1939 Canbus protocol, meaning more precise data collection through less wiring. The wiring itself is made from higher grade material and less prone to interference. The VETUS F-line marine diesel engines meet the RCD2012/53/EU emission regulations.

The F-Line series can be recognized from the V-shaped intercooler and a newly designed top cover which gives this range the well-known VETUS appearance, complemented by a revised heat shield on the turbocharger. Components are rearranged for better accessibility and easy maintenance. The new position of the oil filter is near one of the engine mounts. Moving the filter away from the hot side increases the accessibility and makes room for another improvement: to prevent oil spills with filter changes, a small collector is integrated on the engine mount itself keeping your engine bay clean and tidy.

The VETUS F-line can be supplied as a gearbox and Mercurier sterndrive version.

Specifications

- New VETUS top cover which can be used as a step
- Power output from 145 - 190 hp @ max 4100 rpm
- Canbus system SAEJ1939
- Components repositioned for better accessibility and easy maintenance
- High quality wiring
- Supplied with an aluminium MPA34 Canbus instrument panel
- As an option a potentiometer can be supplied for mechanical controls
- Meets the new RCD2013/53/EU emission regulations
- Suitable for semi-planing and planing boats, RIB'S and tenders, runabouts, speed boats, and cruisers

The extensive VETUS dealer network is on hand to provide service, spare parts and points of contact worldwide. A VETUS marine diesel engine brings with it over 50 years of experience in producing reliable and compact marine engines, ensuring safe and continuous boating pleasure.

All VETUS marine diesel engines come with a 5 year warranty in accordance with the VETUS Warranty and Service Conditions.

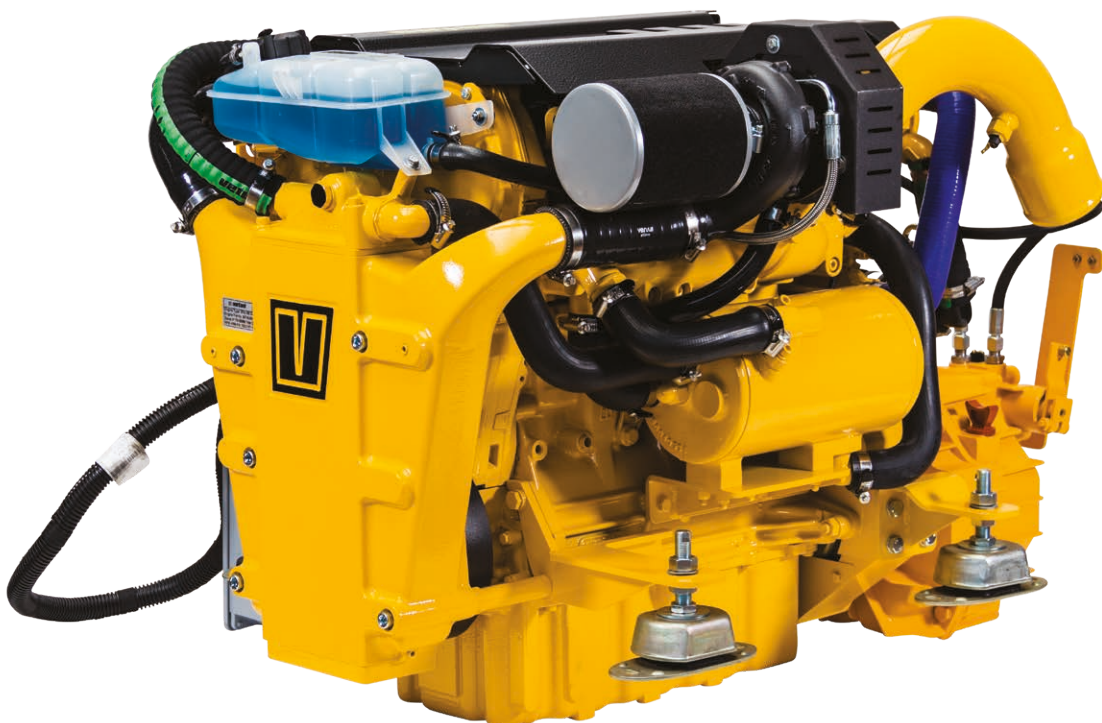

F-LINE

VF4.145

● ● ● ● 108 kW / 145 HP

4 stroke diesel, in line, common rail

TECHNICAL SPECIFICATIONS

Supplied as standard with instrument panel type MPA34CANBS2 (see page 105) and four flexible engine mounts type HY150 (see page 51).



Engine model	VF4.145
CAN bus	SAE J1939
Max. output at flywheel (ISO 3046-1)	108 kW (145 hp)
Max. output at propeller shaft (ISO 3046-1)	104.7 kW (142.4 hp)
Maximum rpm	4100
Bore x stroke	3 ⁹ / ₃₂ " x 3 ¹⁷ / ₃₂ " (83 x 90.4 mm)
Total displacement	119.3 cu.inch (1956 cm ³)
Number of cylinders	4 in line
Injection	Direct injection, common-rail
Intake	Turbo-charged with variable geometry turbo
Compression ratio	16,5:1
Firing order	1-3-4-2
Alternator	12 Volt - 105 Amps.
Torque	280 Nm / 2300 rpm
Idle speed	800 rpm
Fuel consumption at max. rpm	235 g / kW.h

Gearbox (standard)	TM345(A)
Ratio	2 / 2,47:1
Gearbox (optional)	ZF45, TM485A / ZF45A ZF63IV
Sterndrive	Bravo I, II and III
Dry weight (incl. standard gearbox)	705.4 lbs (320 kg)
Fuel lift pump	59 ¹ / ₁₆ " (1.5 m)
Max. installation angle (backwards)	10°
Max. athwartship angle (continuously)	20°

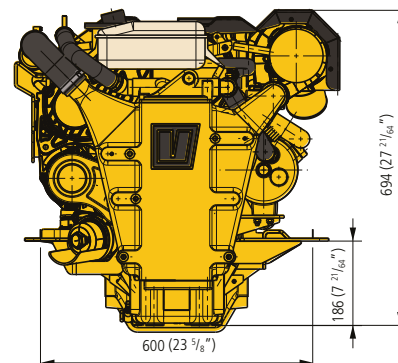
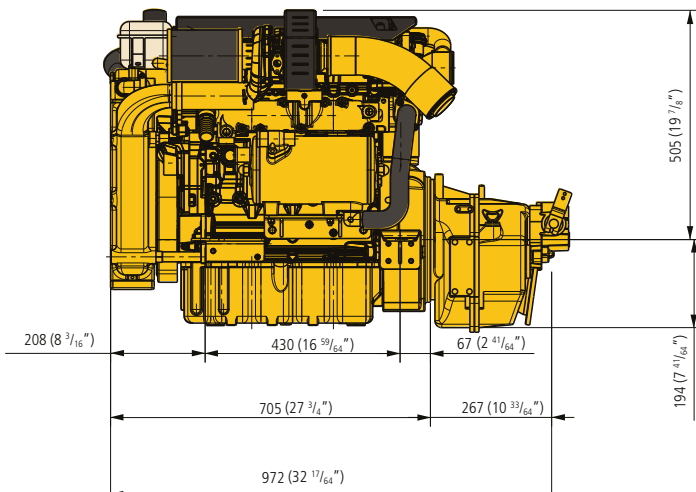
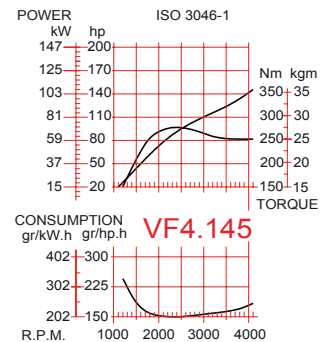

F-LINE

VF4.180

● ● ● ● 129 kW / 175 HP

4 stroke diesel, in line, common rail

TECHNICAL SPECIFICATIONS

Supplied as standard with instrument panel type MPA34CANBS2 (see page 105) and four flexible engine mounts type HY150 (see page 51).



Engine model	VF4.180
CAN bus	SAE J1939
Max. output at flywheel (ISO 3046-1)	129 kW (175 hp)
Max. output at propeller shaft (ISO 3046-1)	125.1 kW (170.1 hp)
Maximum rpm	4100
Bore x stroke	3 ⁹ / ₃₂ " x 3 ¹⁷ / ₃₂ " (83 x 90.4 mm)
Total displacement	119.3 cu.inch (1956 cm ³)
Number of cylinders	4 in line
Injection	Direct injection, common-rail
Intake	Turbo-charged with variable geometry turbo
Compression ratio	16,5:1
Firing order	1-3-4-2
Alternator	12 Volt - 105 Amps.
Torque	340 Nm / 2300 rpm
Idle speed	800 rpm
Fuel consumption at max. rpm	222 g / kW.h

Gearbox (standard)	ZF45
Ratio	2,2 / 2,5 / 3:1
Gearbox (optional)	TM485A / ZF45A
	ZF63IV
Stern drive	Bravo I, II and III
Dry weight (incl. standard gearbox)	705.4 lbs (320 kg)
Fuel lift pump	59 ¹ / ₁₆ " (1.5 m)
Max. installation angle (backwards)	10°
Max. athwartship angle (continuously)	20°

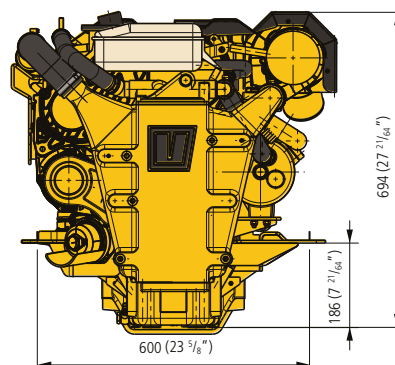
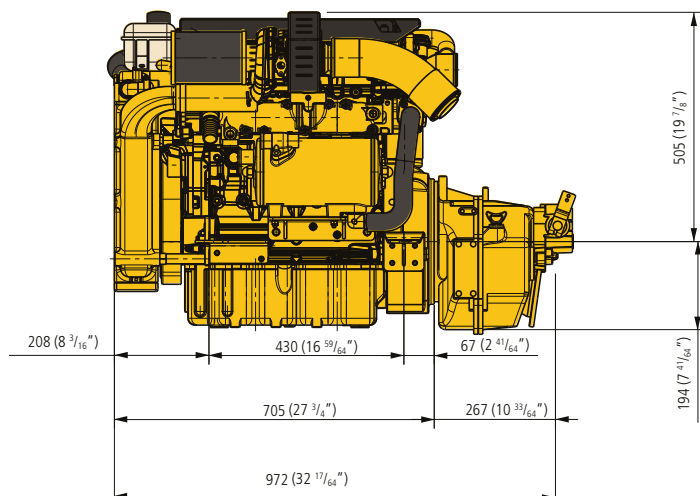
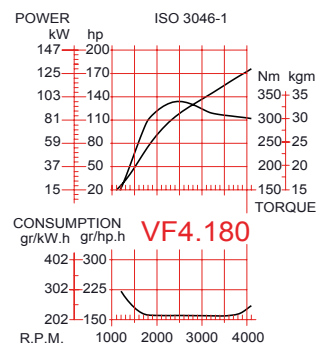

F-LINE

VF4.200

● ● ● ● 140 kW / 190 HP

4 stroke diesel, in line, common rail

TECHNICAL SPECIFICATIONS

Supplied as standard with instrument panel type MPA34CANBS2 (see page 105) and four flexible engine mounts type HY150 (see page 51).



Engine model	VF4.200
CAN bus	SAE J1939
Max. output at flywheel (ISO 3046-1)	140 kW (190 hp)
Max. output at propeller shaft (ISO 3046-1)	135.8 kW (184.3 hp)
Maximum rpm	4100
Bore x stroke	3 ⁹ / ₃₂ " x 3 ¹⁷ / ₃₂ " (83 x 90.4 mm)
Total displacement	119.3 cu.inch (1956 cm ³)
Number of cylinders	4 in line
Injection	Direct injection, common-rail
Intake	Turbo-charged with variable geometry turbo
Compression ratio	16,5:1
Firing order	1-3-4-2
Alternator	12 Volt - 105 Amps.
Torque	355 Nm / 2300 rpm
Idle speed	800 rpm
Fuel consumption at max. rpm	237 g / kW.h

Gearbox (standard)	ZF45
Ratio	2,2 / 2,5 / 3:1
Gearbox (optional)	TM485A / ZF45A
	ZF631V
Stern drive	Bravo I, II and III
Dry weight (incl. standard gearbox)	705.4 lbs (320 kg)
Fuel lift pump	59 ¹ / ₁₆ " (1.5 m)
Max. installation angle (backwards)	10°
Max. athwartship angle (continuously)	20°

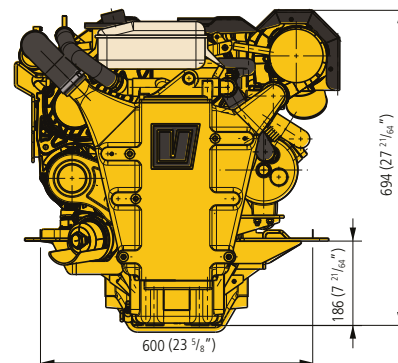
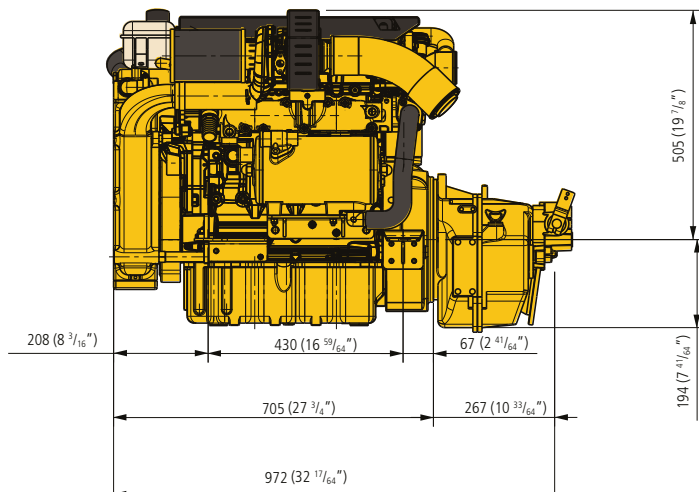
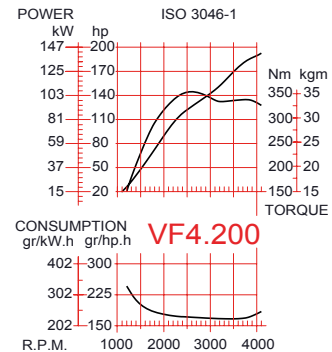

EQUIPMENT SELECTION TABLE FOR F-LINE

Engine model	VF4.145E			VF4.180E				VF4.200E					
Gearbox reduction	1,54:1	2:1	2,47:1	1,26:1	1,51:1	2:1	2,5:1	3:1	1,26:1	1,51:1	2:1	2,5:1	3:1
VETUS lubricated sterngear systems													
* Shaft diam., Duplex 1-4462,	30	35	35	30	35	35	40	40	30	35	35	40	40
VETUS manganese bronze propeller													
* 4 or 5-blade	on request												
VETUS flexible couplings, to be selected													
* Bullflex type	8	12		8	8/12	12	12/16		8	8/12	12	12/16	
VETUS intermediate flange between gearbox and flexible coupling													
* type, suitable for Technodrive gearboxes:	TM345(A): CT50086			TM485(A): CT50009				TM485(A): CT50009					
* type, suitable for ZF gearboxes (not V-drive):	ZF45: CT50068			ZF45A: CT50009				ZF45A: CT50009					
* type, suitable for ZF gearbox for Bullflex 32:	n/a			n/a				n/a					
VETUS water strainer													
* hose connection diam. inches (mm)							1 1/4" (32mm)						
* water strainer, type FTR470, FTR330 or CWS:							FTR47032 or 330/32 / CWS1 1/4						
* water strainer installation kit							WKIT33032						
VETUS fuel filter/water separator													
* hose connection suction/return in inches (mm)							5/16" (8mm) - 5/16" (8mm)						
* fuel filter/water separator, type							75340VTEB or 340VTEB						
VETUS exhaust system with water injection													
* exhaust hose, diam. inches (mm)							3 1/2" 90						
* waterlock, type							NLP / MV / MF or MGP						
* gooseneck, type							LT9090						
* transom connection type							TRC 90SV or PV/TC90						
* anti-siphon, type ASD or AIRVENT							V or H						
VETUS engine remote control													
* type	A mechanical remote control or an electronic remote control can be used with our VF engines												
VETUS maintenance free batteries													
* voltage							12V						
* start battery, Ah							min. 120 Ah, max. 200 Ah						
* light battery, Ah							to be selected						
VETUS louvered air suction vents													
* per engine, type ASV, SSV or SSVL	4 x 70			2 x 80 + 2 x 90 / 2 x 90+ 2 x 100				2 x 80 + 2 x 90 / 2 x 90+ 2 x 100					

Selection table EC3/4 electronic remote control for VETUS VF Engines

1st position = throttle, 2nd position = gearbox

M = Mechanical, E = Electrical

		1 Engine	2 Engines	1 Engine	2 Engines
		M/M	M/M	M/E	M/E
EC3/4 remote control					
EC3/4 handle for 1 engine, without trim	EC3H1/EC4H1(R)	1	xx	1	xx
EC3/4 handle for 2 engines, without trim	EC3H2/4H2	xx	1	xx	1
EC3/4 handle for 1 engine, with trim	EC3HT1/4HT1	1	xx	1	xx
EC3/4 handle for 2 engines, with trim	EC3HT2/4HT2	xx	1	xx	1
VETUS control box					
Control box, engine electronic, gearbox electrical, with trim 12V	EC312EE	xx	xx	1	1
Control box, engine electronic, gearbox electrical, with trolling 12V	EC312EET	xx	xx	1	1
Control box, 1 engine electronic, gearbox mechanical, no trim 12V	EC312EM1	1	xx	xx	xx
Control box, 2 engines electronic, gearbox mechanical, no trim 12V	EC312EM2	xx	1		
Control box, 1 engine electronic, gearbox mechanical, with trim 12V	EC312EMT1	1	xx		
Control box, 2 engines electronic, gearbox mechanical, with trim 12V	EC312EMT2	xx	1		
Required cables					
Can-bus cable control box -> control head 3/5/10 m	DTCAN3/5/10M	1	1	1	1
Extension can-bus cable	DTCAN30M	Optional			
Can-bus T-piece	CANT	Optional			
Push/pull cable	CABLE/CABLF	1	2	xx	xx
Cable from EC312EE to trim/trolling, length 2m	EC3T2	xx	xx	1	2
Cable from control box EC**EE to gearbox L=3m 6 wire	ECG3/6				
Cable from control box EC**EE to gearbox L=5m 6 wire	ECG5/6				
Cable from control box EC**EE to gearbox L=7m 6 wire	ECG7/6				
Cable from control box to VF engine, length 2m	EC3E3M	1	2		



D-LINE

COMMON-RAIL D-LINE ENGINES 122 - 210 HP

VETUS D-Line common-rail engines run smoothly, have a high power and torque, low revolutions and are highly reliable and durable. They are in conformity with the new RCD2 emission regulations. Extremely suitable for power hydraulics on board. These engines have a CAN bus system with a SAEJ1939 protocol but can easily work with NMEA2000 systems on board as well.

These VETUS D-Line engines have a water cooled top cover in order to reduce the heat in the engine room but also to reduce the engine noise of an already quiet engine block. This top cover can be used as a step as well. Other features added to the D-Line engines are: a smaller airfilter in order to save space in the engine room, new exhaust manifold insulation, high output alternator as standard (160 Amps) and a 2nd alternator as an option. When this option is specified, the front belt cover is not fitted. An electric sump pump is fitted as standard.

The following options can be ordered with the engine

- 12V or 24V electrical installation
- Double pole insulation
- PTO for installation a hydraulic pump
- Second alternator 12V / 160 Amps or 24V / 60 Amps
- Second alternator 24V / 75 Amps including ACR regulator (WP)
- Potentiometer for mechanical controls
- Calorifier kit
- Trolling valve
- Extra pulley 2x SPA
- Fly-bridge instrument panel

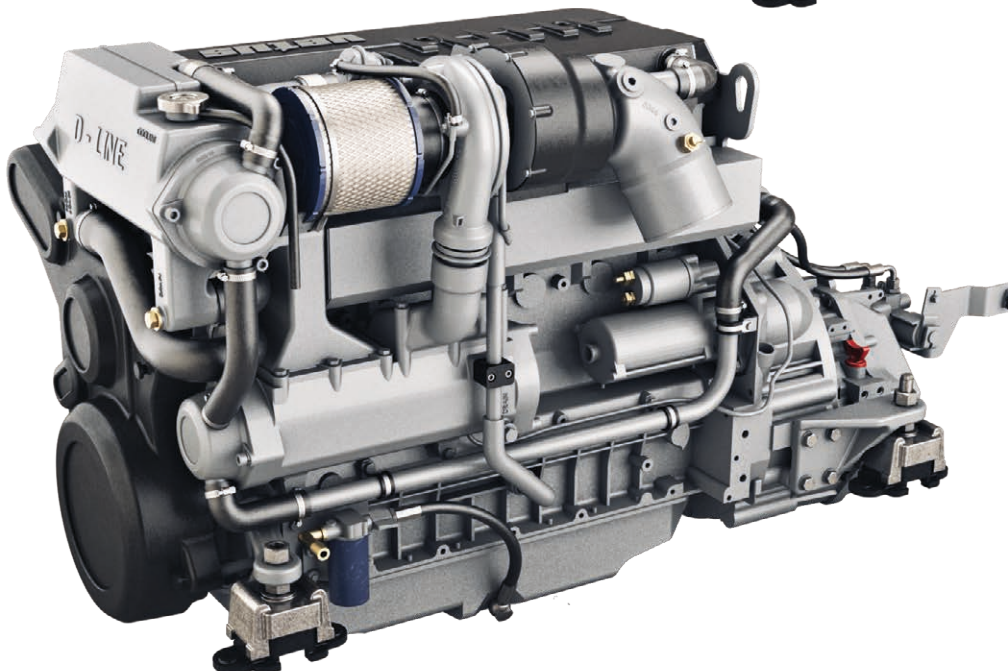
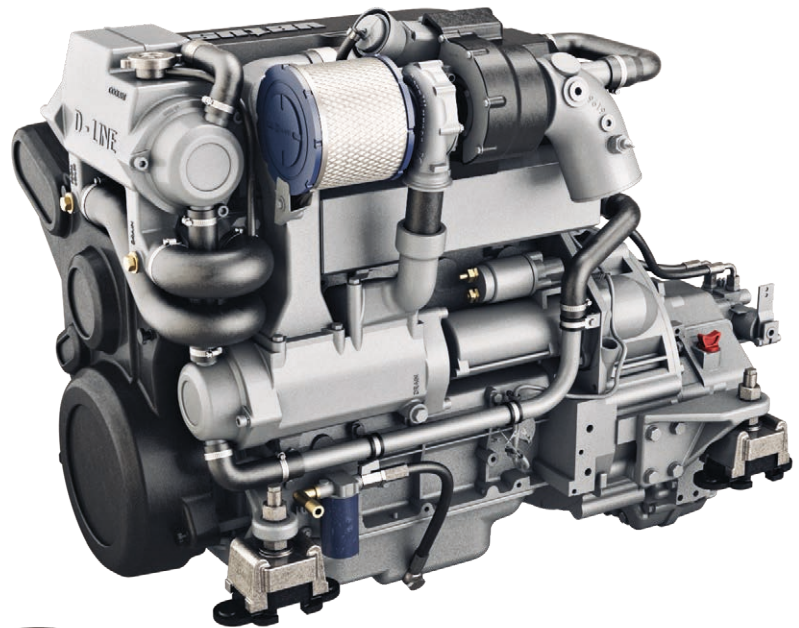

D-LINE

VD4.120

● ● ● ● 90 kW / 122 HP

DI diesel / 4 stroke / 4 cyl. in line
turbo-charged / aftercooled
common rail / EMR 3

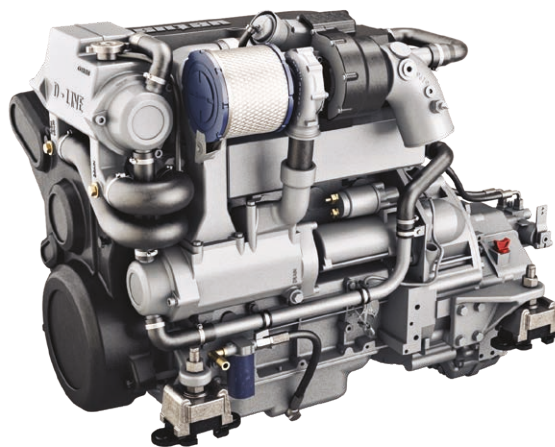

TECHNICAL SPECIFICATIONS

Supplied as standard with instrument panel type MPA34CANBS2 (see page 105) and four flexible engine mounts type LMX140 (see page 51).

Engine model	VD4.120
CAN bus	SAE J1939
Max. output at flywheel (ISO 8665)	90 kW (122 hp)
Max. output at propeller shaft (ISO 8665)	86 kW (117 hp)
Maximum rpm	2400
Bore x stroke	3 ³¹ / ₃₂ " (101 mm) x 4 ⁶¹ / ₆₄ " (126 mm)
Capacity	246.5 cu.inch (4040 cm ³)
Number of cylinders	4 in line
Cooling system	intercooling
Compression ratio	18:1
Firing order	1-3-4-2
Alternator	12 Volt - 160 Amps. 24 Volt - 60 Amps.
Optional 2nd alternator	12 Volt - 160 Amps. 24 Volt - 60 Amps. 24 Volt - 75 Amps. ACR regulator (WP)
Torque	449 Nm / 1600 rpm
Idle speed	800 rpm
Fuel consumption at max. rpm	235 g / kW.h
Gearbox (standard)	ZF45
Ratio	2.2 / 2.51 / 3.1

Gearbox (optional)	ZF45A 1.26:1 / 1.51 / 2.03 / 2.44:1 ZF631V 1.29 / 1.56 / 1.99 / 2.47:1
Dry weight (incl. standard gearbox)	1173 lbs (532 kg)
Fuel lift pump	5 ft. (1.5 m)
Max. installation angle (backwards)	15°
Max. athwartship angle (continuously)	30°
Calorifier connection kit	optional
Electric oil drain pump	standard
P.T.O. flange to install hydr. pump	optional
Instrument panel	MPA34CANBS2
Instruments	Key switch, tacho meter/hour counter, volt meter, oil pressure gauge, temperature gauge
Acoustic alarm	Oil pressure, temperature, charging current fresh and raw water
Electric circuit protection	Resetable circuit breaker
Certification	2013/53/EU RCD II

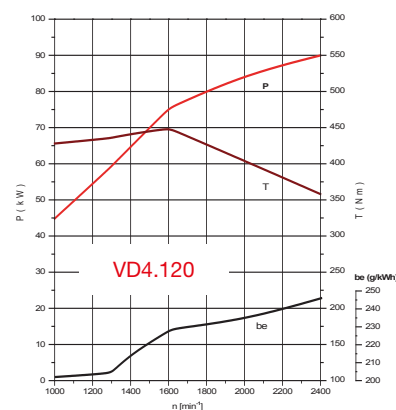
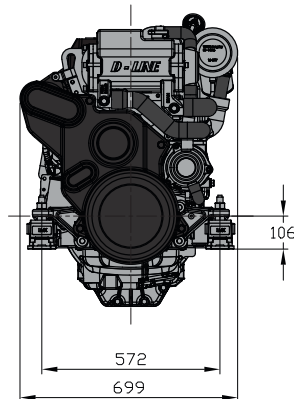
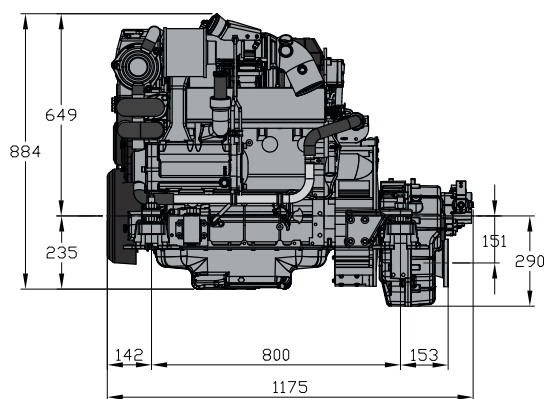

Certified within 5%

D-LINE

VD4.140

● ● ● ● 103 kW / 140 HP

DI diesel / 4 stroke / 4 cyl. in line
turbo-charged / aftercooled
common rail / EMR 3

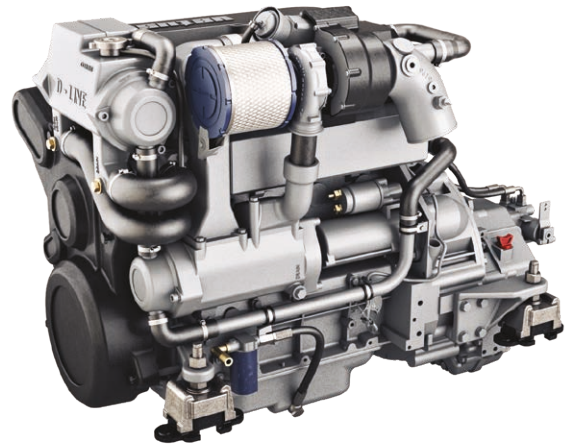

TECHNICAL SPECIFICATIONS

Supplied as standard with instrument panel type MPA34CANBS2 (see page 105) and four flexible engine mounts type LMX140 (see page 51).

Engine model	VD4.140
CAN bus	SAE J1939
Max. output at flywheel (ISO 8665)	103 kW (140 hp)
Max. output at propeller shaft (ISO 8665)	98.9 kW (134.4 hp)
Maximum rpm	2400
Bore x stroke	3 ³¹ / ₃₂ " (101 mm) x 4 ⁶¹ / ₆₄ " (126 mm)
Capacity	246.5 cu.inch (4040 cm ³)
Number of cylinders	4 in line
Cooling system	intercooling
Compression ratio	18:1
Firing order	1-3-4-2
Alternator	12 Volt - 160 Amps. 24 Volt - 60 Amps.
Optional 2nd alternator	12 Volt - 160 Amps. 24 Volt - 60 Amps. 24 Volt - 75 Amps. ACR regulator (WP)
Torque	520 Nm / 1600 rpm
Idle speed	800 rpm
Fuel consumption at max. rpm	235 g / kW.h
Gearbox (standard)	ZF45
Ratio	2.2 / 2.51 / 3.1

Gearbox (optional)	ZF45A 1.26:1 / 1.51 / 2.03 / 2.44:1 ZF63IV 1.29 / 1.56 / 1.99 / 2.47:1
Dry weight (incl. standard gearbox)	1173 (532 kg)
Fuel lift pump	5 ft. (1.5 m)
Max. installation angle (backwards)	15°
Max. athwartship angle (continuously)	30°
Calorifier connection kit	optional
Electric oil drain pump	standard
P.T.O. flange to install hydr. pump	optional
Instrument panel	MPA34CANBS2
Instruments	Key switch, tacho meter/hour counter, volt meter, oil pressure gauge, temperature gauge
Acoustic alarm	Oil pressure, temperature, charging current fresh and raw water
Electric circuit protection	Resetable circuit breaker
Certification	2013/53/EU RCD II

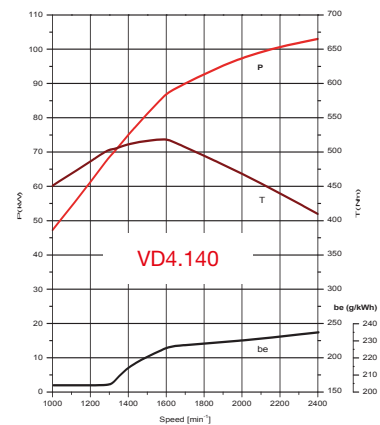
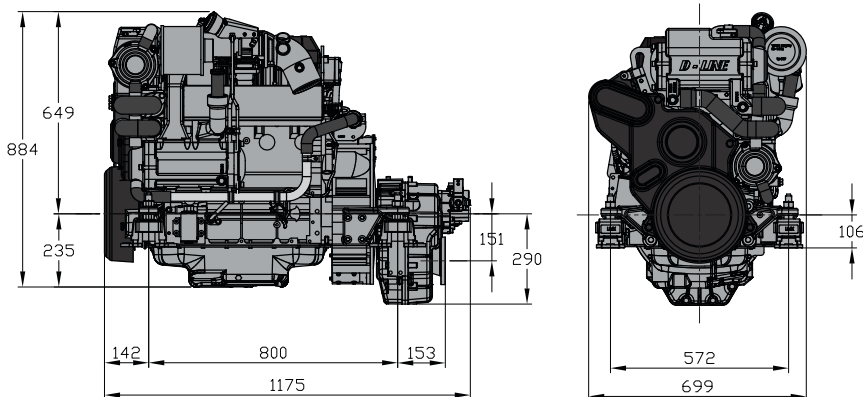

D-LINE

VD6.170

● ● ● ● ● ● 125 kW / 170 HP

DI diesel / 4 stroke / 6 cyl. in line
turbo-charged / aftercooled
common rail / EMR 3

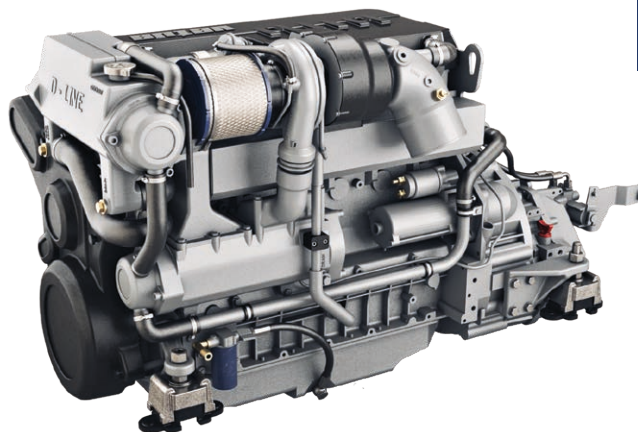

TECHNICAL SPECIFICATIONS

Supplied as standard with instrument panel type MPA34CANBS2 (see page 105) and four flexible engine mounts type LMX210 (see page 51).

Engine model	VD6.170
CAN bus	SAE J1939
Max. output at flywheel (ISO 8665)	125 kW (170 hp)
Max. output at propeller shaft (ISO 8665)	120 kW (163 hp)
Maximum rpm	2400
Bore x stroke	3 ³¹ / ₃₂ " (101 mm) x 4 ⁶¹ / ₆₄ " (126 mm)
Capacity	369.8 cu.inch (6060 cm ³)
Number of cylinders	6 in line
Cooling system	intercooling
Compression ratio	18:1
Firing order	1-5-3-6-2-4
Alternator	12 Volt - 160 Amps. 24 Volt - 60 Amps.
Optional 2nd alternator	12 Volt - 160 Amps. 24 Volt - 60 Amps. 24 Volt - 75 Amps. ACR regulator (WP)
Torque	680 Nm / 1600 rpm
Idle speed	800 rpm
Fuel consumption at max. rpm	240 g / kW.h
Gearbox (standard)	ZF63
Ratio	1.51 / 1.93 / 2.48 / 2.78:1

Gearbox (optional)	ZF63A 1.22 / 1.56 / 2.04 / 2.52:1 ZF63IV 1.29 / 1.56 / 1.99 / 2.47:1
Dry weight (incl. standard gearbox)	1448 lbs (657 kg)
Fuel lift pump	5 ft. (1.5 m)
Max. installation angle (backwards)	15°
Max. athwartship angle (continuously)	26°
Calorifier connection kit	optional
Electric oil drain pump	standard
P.T.O. flange to install hydr. pump	optional
Instrument panel	MPA34CANBS2
Instruments	Key switch, tacho meter/hour counter, volt meter, oil pressure gauge, temperature gauge
Acoustic alarm	Oil pressure, temperature, charging current fresh and raw water
Electric circuit protection	Resetable circuit breaker
Certification	2013/53/EU RCD II

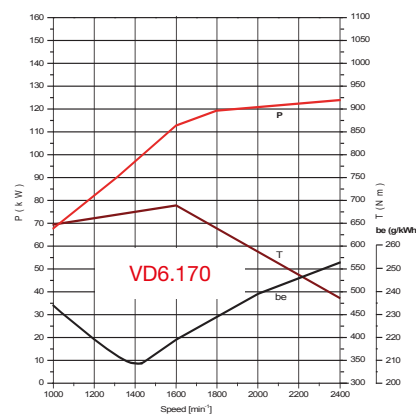
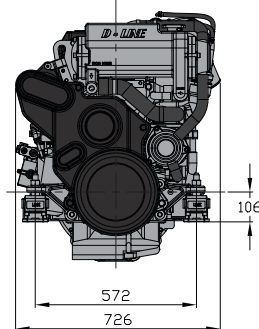
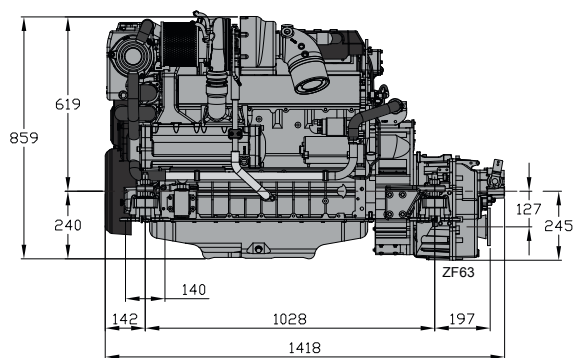

Certified within 5%

D-LINE

VD6.210

● ● ● ● ● ● 155 kW / 210 HP

DI diesel / 4 stroke / 6 cyl. in line
turbo-charged / aftercooled
common rail / EMR 3

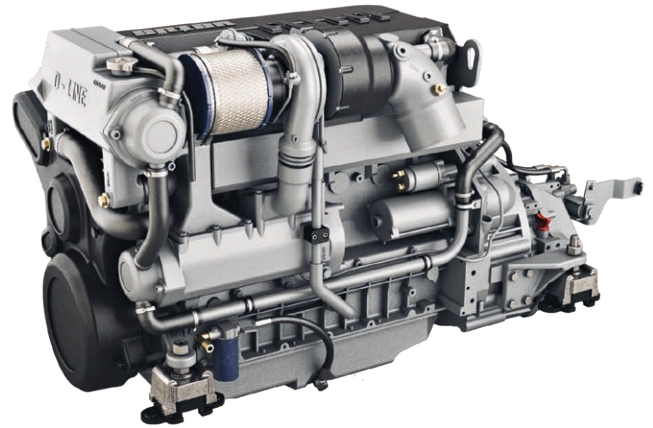

TECHNICAL SPECIFICATIONS

Supplied as standard with instrument panel type MPA34CANBS2 (see page 105) and four flexible engine mounts type LMX210 (see page 51).



Engine model	VD6.210
CAN bus	SAE J1939
Max. output at flywheel (ISO 8665)	155 kW (210 hp) (VD6.210)
Max. output at propeller shaft (ISO 8665)	149 kW (203 hp) (VD6.210)
Maximum rpm	2400
Bore x stroke	3 ³¹ / ₃₂ " (101 mm) x 4 ⁶¹ / ₆₄ " (126 mm)
Capacity	369.8 cu.inch (6060 cm ³)
Number of cylinders	6 in line
Cooling system	intercooling
Compression ratio	18:1
Firing order	1-5-3-6-2-4
Alternator	12 Volt - 160 Amps. 24 Volt - 60 Amps.
Optional 2nd alternator	12 Volt - 160 Amps. 24 Volt - 60 Amps. 24 Volt - 75 Amps. ACR regulator (WP)
Torque	810 Nm / 1600 rpm
Idle speed	800 rpm
Fuel consumption at max. rpm	240 g / kW.h
Gearbox (standard)	ZF63
Ratio	1.51 / 1.93 / 2.48 / 2.78:1

Gearbox (optional)	ZF63A 1.22 / 1.56 / 2.04 / 2.52:1 ZF63IV 1.29 / 1.56 / 1.99 / 2.47:1
Dry weight (incl. standard gearbox)	1448 lbs (657 kg)
Fuel lift pump	5 ft. (1.5 m)
Max. installation angle (backwards)	15°
Max. athwartship angle (continuously)	26°
Calorifier connection kit	optional
Electric oil drain pump	standard
P.T.O. flange to install hydr. pump	optional
Instrument panel	MPA34CANBS2
Instruments	Key switch, tacho meter/hour counter, volt meter, oil pressure gauge, temperature gauge
Acoustic alarm	Oil pressure, temperature, charging current fresh and raw water
Electric circuit protection	Resetable circuit breaker
Certification	2013/53/EU RCD II

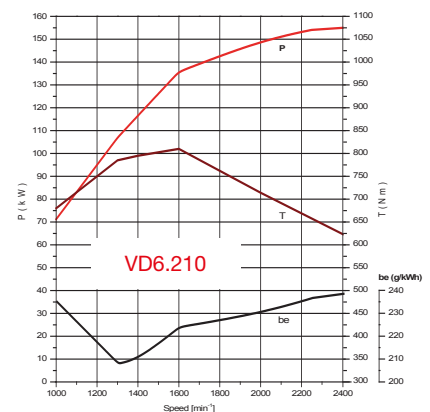
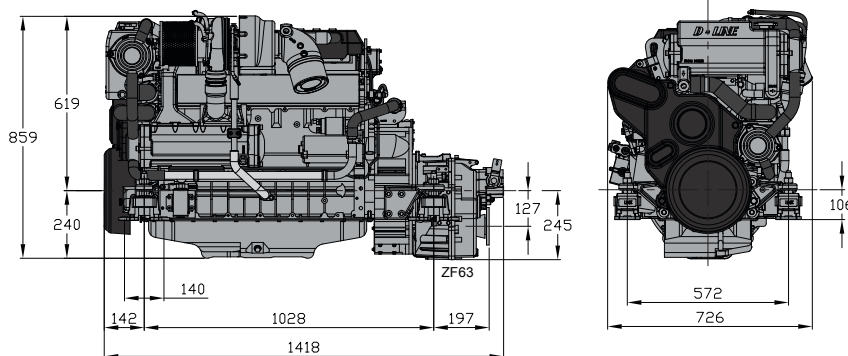

Certified within 5%

EQUIPMENT SELECTION TABLE FOR D-LINE



VDR

See flexible couplings on page 70



75330VTEB

See fuel filters on page 124



CWS

See water strainers on page 54



MGP

See waterlocks on page 90 and 92



HPW127

Engine model	VD4.120		VD4.140		VD6.170		VD6.210	
Gearbox reduction	2,2:1	2,5:1	2,2:1	2,5:1	2,04:1	2,5:1	2,04:1	2,5:1
VETUS water lubricated propeller shaft system								
* Shaft diam., Duplex 1-4462	40	40	40	40	45	45	45	50
VETUS manganese bronze propeller								
* 3- or 4-blade	on request							
VETUS flexible couplings								
* Bullflex type	12	12	12	16	16	16	16	32
VETUS intermediate flange between gearbox and flexible coupling								
* Type, only suitable for ZF gearbox	ZF45A: CT50009; ZF45: CT50068; ZF63(A)/16: CT50009; ZF63(A)/32: CT50065							
VETUS constant velocity joint with integrated thrust bearing								
* Type	depending on the application							
* Dimensions gearbox flange	ZF45: 6", ZF45A: 5", ZF63: 5", ZF63A: 5"							
VETUS water strainers								
* hose connection inches (mm)	1 1/4" (32)							
* water strainer, type FTR470, FTR330 or CWS:	330 or 470/32 / CWS1 1/4							
* water strainer kit, type	WKIT33032							
VETUS water separator / fuel filter								
* hose connection suction/return in inches (mm)	1/2" - 3/8" (12 - 10)							
* water separator / fuel filter, type:	(75)330VTEB or WS720							
VETUS water-injected exhaust systems								
* exhaust hose, diam. inches (mm)	4" (100)				5" (125)			
* waterlock, type	MF or MGP				MF - MGS or HPW127			
* muffler, type	MP100				n.a.			
* gooseneck, type	LT102				LT127			
* exhaust transom connection, type	TRCR/PV or SV							
* anti-siphon, type AIRVENT or ASD	AIRVENTV or -H/ASDV or -H							
VETUS engine remote controls								
* to be selected	SICO, SISCO, AFSTZIJ, RCTOPB, RCTOPS, AFSTTOP, EC4							
VETUS maintenance free batteries								
* voltage	12							
* start battery, min. Ah	108							
* light battery, Ah	to be selected							
VETUS louvered air suction vents								
* per engine, type ASV, SSV or SSVL	2 x 60 + 2 x 70		4 x 70		2 x 80 + 2 x 90		4 x 50 + 4 x 60	



SOLAS ENGINES

VETUS marinises diesel engines and has become a well-known brand in the marine market. The quality and reliability of the famous VETUS yellow engines is well-known by boat builders. Now VETUS also offers a range of SOLAS approved engines for life and rescue boats and tenders.

The range comprises of four models

M3.28 - 27hp @ 3600 rpm

M4.15 - 33hp @ 3000 rpm

M4.17 - 42hp @ 3000 rpm

M4.55 - 52hp @ 3000 rpm

Standard specification

- Keelcooling system with thermostat and dry exhaust fitting
- Tilt switch
- Marinisation parts with anti-corrosion treatment
- Electric fuel lift pump
- Automatic self-bleeding system
- Fuel filter/water separator
- Electric start
- Air inlet filter
- Alternator 12V/75A (M3) or 12V/110A (M4)
- Remote control panel type MP10 including 2 metre cable, warning lights and audible alarm for low oil pressure, high coolant temperature and exhaust temperature and manual turn switch for start and stop
- V-belt cover
- Pre-installed sump pump

Options

- Intercooling system with dry-run impeller. Includes exhaust injection bend with seawater protection alarm
- Fire fighting pump bracket + fire fighting pump
- Engine heating (48 Volt)
- Spring starter
- Hydraulic starter
- Remote control panels type MP22 or MP34
- Flexible engine mounts
- Bracket for remote oil and fuel filter
- Spare parts kit
- Complete propeller shaft system
- Exhaust system for intercooled engines
- Remote controls and push-pull cables
- All other around the engine equipment



AROUND THE ENGINE

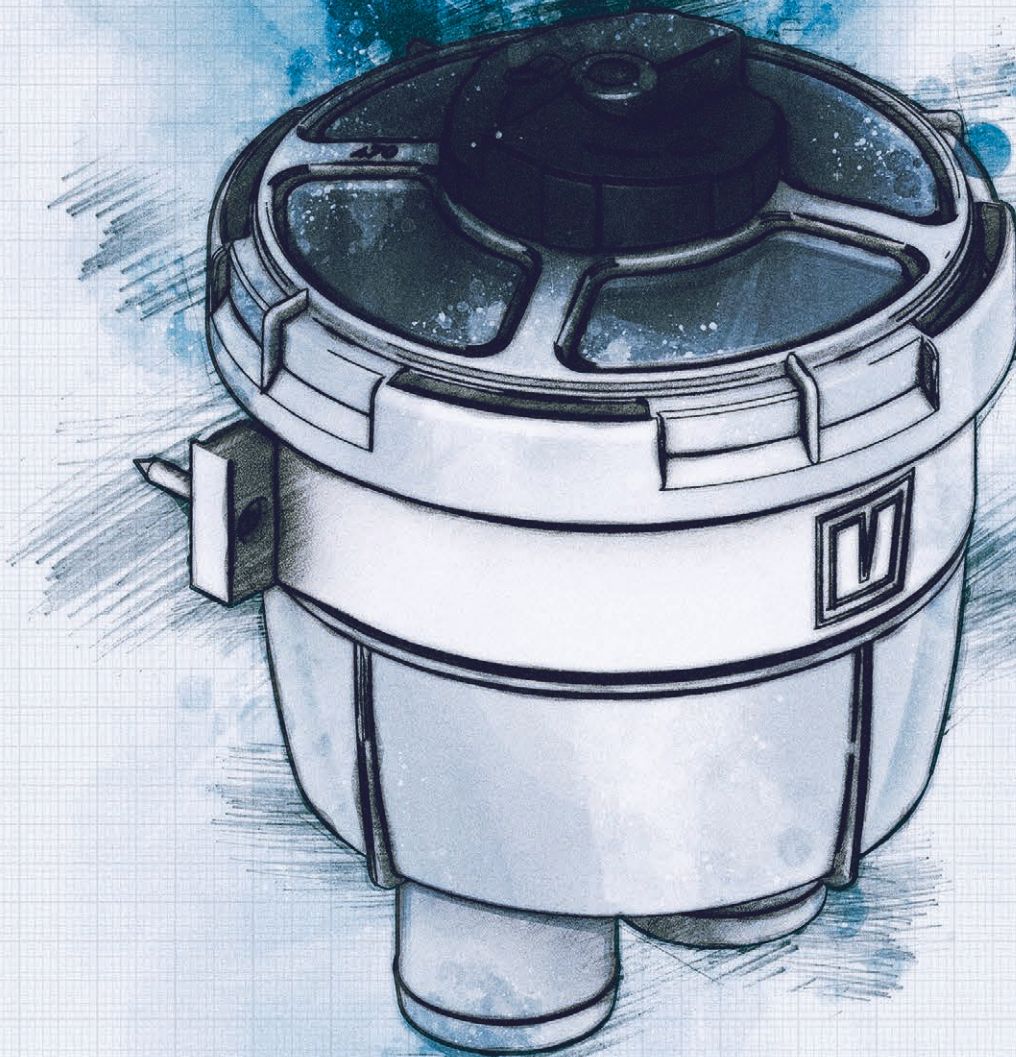

Overview VETUS around the engine

Mechanical engine remote controls see page 44



Electronic engine remote controls see page 46



Push-pull cables and accessories see page 49

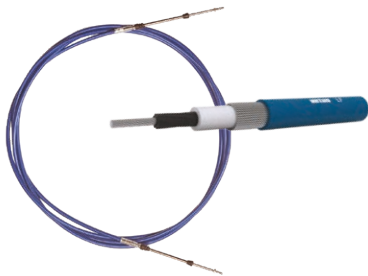

Flexible engine mounts see page 50



Cooling water strainers see page 52



Sound insulation materials see page 56

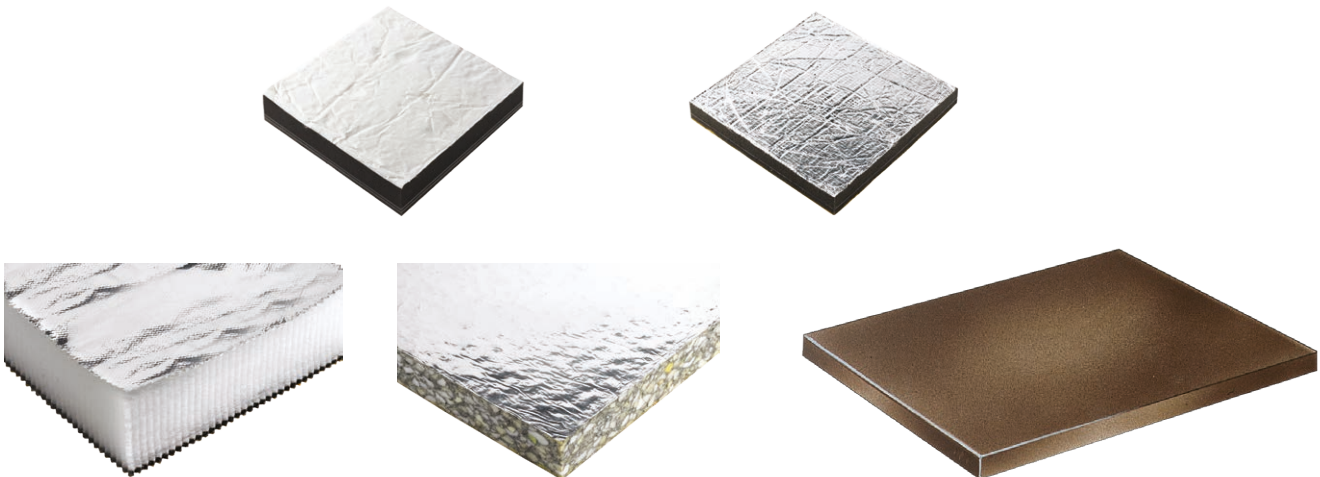

MECHANICAL ENGINE REMOTE CONTROLS

All remote controls (except type AFST) have a neutral safety switch as standard, which prevents the engine from being started when the gearbox is engaged. Controls which are shown with a red knob are also supplied with a black knob as standard.

Type SISCO - single lever

With stainless steel (AISI 316) handle and housing

VETUS single lever remote control for side mounting. The push-pull cables can be installed horizontally or vertically.

Type	Length inches (mm)	Width inches (mm)	Height inches (mm)	Handle length from centre inches (mm)	Mechanism depth from centre inches (mm)
SISCO	5 ²⁵ / ₃₂ (142)	5 (122)	3 (85)	7 ⁷ / ₈ (200)	9 ¹⁹ / ₃₂ (243)
SISCOG	5 ²⁵ / ₃₂ (142)	5 (122)	3 (85)	7 ⁷ / ₈ (200)	9 ¹⁹ / ₃₂ (243)



SISCO

SISCOG

Type SICO - single lever

With stainless steel (AISI 316) handle and plastic housing

VETUS single lever remote control for side mounting.

Type	Length inches (mm)	Width inches (mm)	Height inches (mm)	Handle length from centre inches (mm)	Mechanism depth from centre inches (mm)
SICO	5 ²⁵ / ₃₂ (147)	5 (127)	3 (85)	7 ⁷ / ₈ (200)	9 ¹⁹ / ₃₂ (243)
SICOG	5 ²⁵ / ₃₂ (147)	5 (127)	3 (85)	7 ⁷ / ₈ (200)	9 ¹⁹ / ₃₂ (243)



SICO

SICOG

Type RCTOPS - single lever

With high-gloss polished stainless steel (AISI 316) handle and housing

VETUS single lever remote control for top mounting.

Type	Length inches (mm)	Width inches (mm)	Height inches (mm)	Handle length from centre inches (mm)	Mechanism depth inches (mm)
RCTOPS	6 ³ / ₈ (162)	7 ³ / ₃₂ (104)	9 ¹⁹ / ₆₄ (237)	7 ⁷ / ₈ (200)	8 ³ / ₁₆ (208)
RCTOPSG	6 ³ / ₈ (162)	7 ³ / ₃₂ (104)	9 ¹⁹ / ₆₄ (237)	7 ⁷ / ₈ (200)	8 ³ / ₁₆ (208)



RCTOPS

RCTOPSG

Type RCTOPTS - twin lever

With high-gloss polished stainless steel (AISI 316) handles and housing

VETUS twin lever remote control for top mounting.

Type	Length inches (mm)	Width inches (mm)	Height inches (mm)	Handle length from centre inches (mm)	Mechanism depth inches (mm)
RCTOPTS	6 ³ / ₈ (162)	7 ⁷ / ₈ (200)	9 ¹⁹ / ₆₄ (237)	7 ⁷ / ₈ (200)	8 ³ / ₁₆ (208)
RCTOPTSG	6 ³ / ₈ (162)	7 ⁷ / ₈ (200)	9 ¹⁹ / ₆₄ (237)	7 ⁷ / ₈ (200)	8 ³ / ₁₆ (208)



RCTOPTS

RCTOPTSG

MECHANICAL ENGINE REMOTE CONTROLS

Type RCTOPTB - twin lever

With cast aluminium housing and stainless steel (AISI 316) handles

VETUS twin lever remote control for top mounting

Type	Length inches (mm)	Width inches (mm)	Height inches (mm)	Mechanism depth inches (mm)
RCTOPTB	6 ³ / ₈ (162)	7 ⁷ / ₈ (200)	9 ¹⁹ / ₆₄ (237)	8 ³ / ₁₆ (208)
RCTOPTBG	6 ³ / ₈ (162)	7 ⁷ / ₈ (200)	9 ¹⁹ / ₆₄ (237)	8 ³ / ₁₆ (208)



RCTOPTB



RCTOPTBG

Type RCTOPB - single lever

With cast aluminium housing and stainless steel (AISI 316) handles

VETUS single lever remote control for top mounting

Type	Length inches (mm)	Width inches (mm)	Height inches (mm)	Mechanism depth inches (mm)
RCTOPB	6 ³ / ₈ (162)	7 ³ / ₃₂ (104)	9 ¹⁹ / ₆₄ (237)	8 ³ / ₁₆ (208)
RCTOPBG	6 ³ / ₈ (162)	7 ³ / ₃₂ (104)	9 ¹⁹ / ₆₄ (237)	8 ³ / ₁₆ (208)



RCTOPB



RCTOPBG

Black/silver plastic housings with black metal and plastic levers

(Without neutral safety switch)

Type AFSTTOPT

VETUS twin lever control for top mounting with plastic housing and handle. Top mounting for 2 engines.

Type AFSTTOP

VETUS single lever control for top mounting with plastic housing and handle. Top mounting for 1 engine.

Type	Length inches (mm)	Width inches (mm)	Height inches (mm)
AFSTTOPT	6 ¹ / ₁₆ (154)	8 ³ / ₁₆ (208)	9 ³ / ₈ (238)
AFSTTOP	6 ¹ / ₁₆ (154)	4 ⁴¹ / ₆₄ (118)	9 ³ / ₈ (238)



AFSTTOPT



AFSTTOP

Type AFSTZIJ

This side mount engine control can be used with mechanically controlled engines from 12 - 110 hp. The AFSTZIJ should be mounted in reach of the vessel's helm on either port or starboard side.

The mechanical part of the lever is made of painted zinc, finished with a plastic housing and an ergonomically shaped rubber grip. The AFSTZIJ works with push/pull cables and features an integrated safety mechanism to protect the transmission. The gearbox can only be shifted at idling speed. The AFSTZIJ is the ideal engine control for sailing boats.

Type	Length inches (mm)	Width inches (mm)	Height inches (mm)
AFSTZIJ	5 ⁷ / ₁₆ (138)	4 ²¹ / ₆₄ (110)	3 ⁵ / ₆₄ (78)

AFSTZIJ



ELECTRONIC ENGINE REMOTE CONTROL

Type EC4

High quality with the latest technology

This high quality electronic engine control lever is made of high-grade stainless steel (AISI 316) with hand-polished stainless steel (AISI 316) casing and is suitable for power and sailing yachts. It can operate 1 or 2 engines and has multiple helm station possibilities with identical controls at all helm stations. The communication goes via CAN-bus protocol.

The EC4 is easy to install and configure and meets the EMC requirements as standard.

Characteristics

- Available for 12 and 24 Volt
- Waterproof (IP67)
- Suitable for mechanically controlled engines, combination mechanical / electronic engine control or fully electronic engine control
- Suitable for mechanical or hydraulic gearboxes and stern drives

Optional

Trolling valve control, trim tab or bow thruster control.



EC4

Type	Length inches (mm)	Width inches (mm)	Height inches (mm)	Engines
EC4H1	5 ⁵ / ₁₆ (151)	5 ¹ / ₂ (140)	6 ¹¹ / ₁₆ (161)	1 (left handle)
EC4H1R	5 ⁵ / ₁₆ (151)	5 ¹ / ₂ (140)	6 ¹¹ / ₁₆ (161)	1 (right handle)
EC4HT1	5 ⁵ / ₁₆ (151)	5 ¹ / ₂ (140)	6 ¹¹ / ₁₆ (161)	1 with trim control
EC4H2	5 ⁵ / ₁₆ (151)	5 ¹ / ₂ (140)	6 ¹¹ / ₁₆ (161)	2
EC4HT2	5 ⁵ / ₁₆ (151)	5 ¹ / ₂ (140)	6 ¹¹ / ₁₆ (161)	2 with trim control

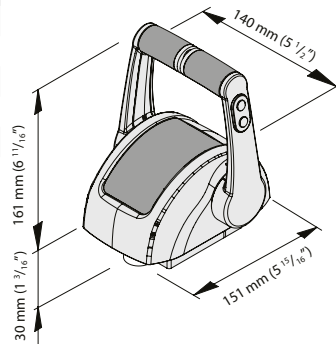

This engine control can be used with electrical and / or mechanical controlled diesel engines and gearboxes. Ask your dealer for more information.

Type EC3

The housing of the EC3 model is made from composites. All other technical specifications are the same as the EC4.

Type	Length inches (mm)	Width inches (mm)	Height inches (mm)	Engines
EC3H1	6 ¹ / ₈ (155)	6 ¹ / ₈ (155)	6 ¹⁴ / ₁₆ (174)	1
EC3HT1	6 ¹ / ₈ (155)	6 ¹ / ₈ (155)	6 ¹⁴ / ₁₆ (174)	1 with trim control
EC3H2	6 ¹ / ₈ (155)	6 ¹ / ₈ (155)	6 ¹⁴ / ₁₆ (174)	2
EC3HT2	6 ¹ / ₈ (155)	6 ¹ / ₈ (155)	6 ¹⁴ / ₁₆ (174)	2 with trim control

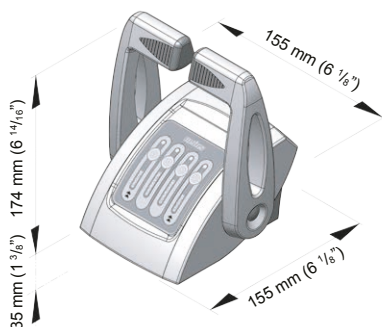

EC3

Selection table



EC3 / EC4 Electronic motor control system			1 Engine	2 Engine	1 Engine	2 Engine	1 Engine	2 Engine	1 Engine	2 Engine	Optional
Control method: first position=Throttle, Second position = Gear actuation M = mechanical, E = Electrical			M/M	M/M	M/E	M/E	E/E	E/E	E/M	E/M	Per extra control head Max. total units = 4
EC3 Composite control head 1 engine	EC3H1		O = 1		O = 1		O = 1		O = 1		+1/+2/+3
EC3 Composite control head 1 engine + Trim buttons	EC3HT1		O = 1		O = 1		O = 1		O = 1		+1/+2/+3
EC3 Composite control head twin engines	EC3H2			O = 1		O = 1		O = 1		O = 1	+1/+2/+3
EC3 Composite control head twin engines + Trim buttons	EC3HT2			O = 1		O = 1		O = 1		O = 1	+1/+2/+3
EC4 Stainless steel control head 1 engine	EC4H1/ EC4H1R (right)		O = 1		O = 1		O = 1		O = 1		+1/+2/+3
EC4 Stainless steel control head 1 engine + Trim buttons	EC4HT1		O = 1		O = 1		O = 1		O = 1		+1/+2/+3
EC4 Stainless steel control head 2 engines	EC4H2			O = 1		O = 1		O = 1		O = 1	+1/+2/+3
EC4 Stainless steel control head 2 engines + Trim buttons	EC4HT2			O = 1		O = 1		O = 1		O = 1	+1/+2/+3
Electronic control box for full mechanical control	12 +24V	EC3UMM1	1	2	x	x	x	x	x	x	
Electronic control box for full mechanical control and trim	12+24V	EC3UMMT1	1	2	x	x	x	x	x	x	
Electronic control box for mechanical motor and electrical gear	12+24V	EC3UME1	x	x	1	2	x	x	x	x	
Electronic control box for 2 mechanical motor and electrical gear	12+24V	EC3UME2	x	x	x	1	x	x	x	x	
Electronic control box for mechanical motor and electrical gear and trim	12+24V	EC3UMET1	x	x	1	2	x	x	x	x	
Electronic control box for 2 mechanical motor and electrical gear and trim	12+24V	EC3UMET2	x	x	x	1	x	x	x	x	
Electronic control box for mechanical motor and electrical gear and trolling	12+24V	EC3UMETR1	x	x	1	2	x	x	x	x	
Electronic control box for full electric control and trim	12V	EC312EE	x	x	x	x	1	1	x	x	
Electronic control box for full electric control and trim	12V+24V	EC3UEE	x	x	x	x	1	1	x	x	
Electronic control box for full electric control and trolling	12+24V	EC312EET	x	x	x	x	1	1	x	x	
Electronic control box for electric motor control and mechanical gear	12V	EC312EM1	x	x	x	x	x	x	1	2	
Electronic control box for electric motor control and mechanical gear and trim	12V	EC312EMT1	x	x	x	x	x	x	1	2	
Electric throttle cable universal L=3M		EC3E3U	x	x	x	x	O = 1	O = 2	O = 1	O = 2	
Electric throttle cable for VF engine L=3M		EC3E3M	x	x	x	x	O = 1	O = 2	O = 1	O = 2	
Electric gear cable L=3M (12V only boxes 3 wires)		EC3G3M	x	x	O = 1	O = 2	O = 1	O = 2	x	x	***
Electric gear cable L=3M (12V+24V boxes 6 wires)		ECG3/6	x	x	O = 1	O = 2	O = 1	O = 2	x	x	
Electric gear cable L=5M (12V+24V boxes 6 wires)		ECG5/6	x	x	O = 1	O = 2	O = 1	O = 2	x	x	
Electric gear cable L=7M (12V+24V boxes 6 wires)		ECG7/6	x	x	O = 1	O = 2	O = 1	O = 2	x	x	
Trim/Trolling cable L=2M		EC3T2	O = 1		O = 1		O = 1		O = 1		
Trim/Trolling cable L=3M		EC3T3	O = 1		O = 1		O = 1		O = 1		
Trim/Trolling cable L=3M for Mercruiser		EC3T3MM	O = 1		O = 1		O = 1		O = 1		

x = Not applicable O = Optional *** = For box with 3p connector



ELECTRONIC ENGINE REMOTE CONTROL

Type ECS

The ECS electronic engine controls developed by Rexroth meet the highest production and quality standards and provide operators with maximum reliability, as proven by endurance testing with one million lever actuations. They feature plug-and-play installation and easy operation with a unique design and extensive range of options.

Type ECS can be used to control single or twin engine applications from up to four control stations. Trolling gear control is available as an option. The system is designed for pleasure and small work boats and is compatible with all common engine types and reversing gears. The hardware originates from proven automotive applications. The well-established CAN-bus technology ensures reliable communication between all the components. Sophisticated auto-diagnostics inform the operator of the current operating state.



ECS

Type	Length inches (mm)	Width inches (mm)	Height inches (mm)
ECSH1	4 ⁵⁹ / ₆₄ (125)	5 ¹ / ₈ (130)	6 ⁵ / ₁₆ (160)
ECSH2	4 ⁵⁹ / ₆₄ (125)	5 ¹ / ₈ (130)	6 ⁵ / ₁₆ (160)

Design - pairing form with function

- Timeless appearance
- Easy to integrate
- Backlit illumination

User experience

- Wi-Fi web server for diagnostics
- Auto-configuration
- Language-independent icons
- Plug and play installation

Safety

- Proven BOSCH components
- ABYC compliant

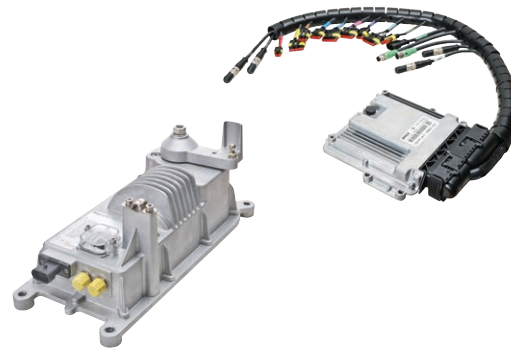

Electronic motor control system	1 Engine		2 Engines		1 Engine		2 Engines		Optional
	1	2	1	2	1	2	1	2	
Control method first position=Throttle, Second position = Gearbox M = Mechanical, E = Electrical	M/M	M/M	M/E	M/E	E/M	E/M	E/E	E/E	Per extra control head. Max. total units = 4
ECS Control head 1 engine	1	xx	1	xx	1	xx	1	xx	+1/+2/+3
ECS Control head twin engines	xx	1	xx	1	xx	1	xx	1	+1/+2/+3
ECS system control unit	1	1	1	1	1	1	1	1	
ECS Single engine wiring harness	1	xx	1	xx	1	xx	1	xx	
ECS Twin engine wiring harness	xx	1	xx	1	xx	1	xx	1	
ECS Actuator 12/24V (incl. 1 connection kit for push-pull cable *)	2	4	1	2	1	2	xx	xx	
Mechanical push-pull cables and connectors									
ECS power cable 5/10 m (**)	3	5	2	3	2	3	xx	xx	
ECS bus cable (station and prop). 5/10/15/20/30 m	3	5	2	3	2	3	1	1	+1/+2/+3
ECS gender changer male / female (to extend standard cable length)	0	0	0	0	0	0	0	0	
ECS Terminating resistor	2	2	2	2	2	2	xx	xx	
ECS Gear control cable without connector 10 m /a	xx	xx	1 (a/b)	2 (a/b)	xx	xx	1 (a/b)	2 (a/b)	
ECS Gear control cable solenoid valve 5/10 m /b	xx	xx	1 (a/b)	2 (a/b)	xx	xx	1 (a/b)	2 (a/b)	
ECS electrical throttle cable 4-20mA 10/20 m /c	xx	xx	xx	xx					
ECS electrical throttle cable 0-5V 10/20 m /d	xx	xx	xx	xx	1 (c/d/e)	2 (c/d/e)	1 (c/d/e)	2 (c/d/e)	
ECS electrical throttle cable PWM 10/20 m /e	xx	xx	xx	xx					
ECS auxilliary cable start interlock 10 m	0 = 1	0 = 2	0 = 1	0 = 2	0 = 1	0 = 2	0 = 1	0 = 2	
ECS cable start interlock contact safety stop high idle 10 m	0 = 1	0 = 2	0 = 1	0 = 2	0 = 1	0 = 2	0 = 1	0 = 2	
ECS cable alarm and monitoring interface 10 m	0 = 1	0 = 2	0 = 1	0 = 2	0 = 1	0 = 2	0 = 1	0 = 2	
ECS Power ignition cable 20 m	0 = 1	0 = 1	0 = 1	0 = 1	0 = 1	0 = 1	0 = 1	0 = 1	
ECS trolling/PWM (special order)									

(*) Mechanical push pull cables to be ordered from the VETUS catalogue

(**) 10M power supply wire not to be used with 12V actuator

xx = Not applicable (a/b/c/d/e) = Select correct cable 0 = Optional

PUSH-PULL CABLES

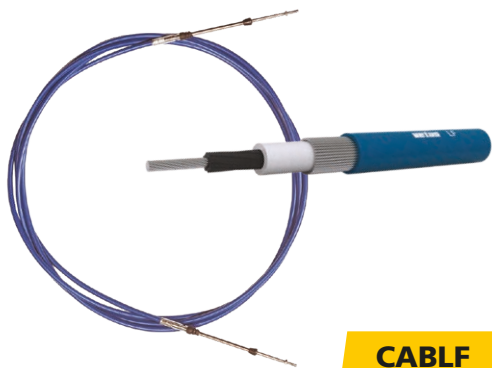

CABLF

Type LF (low friction)

Superb strength and flexibility

This high quality cable utilises a multi-strand wire core and a ribbed synthetic sheath to ensure that contact with the outer casing is kept to a minimum. Type LF is ideal for long and complicated runs and dual station installations.

Specifications

- Available lengths from 1.6 ft (0,5 m) to 33 ft (15 m) (up to 50 ft (17 m) available to special order)
- Nominal travel 3" (75 mm)
- Minimum bend radius 6½" (165 mm)
- Stroke 3" (76,2 mm)
- Standard rod 10-32 UNF threaded ends

Type	Description
CABLF05	LF cable, length 1.64 ft (0.5 m)
CABLF10	LF cable, length 3.28 ft (1.0 m)
CABLF15	LF cable, length 5 ft (1.5 m)
CABLF20	LF cable, length 6.65 ft (2.0 m)
CABLF25	LF cable, length 8.2 ft (2.5 m)
CABLF30	LF cable, length 9.84 ft (3.0 m)
CABLF35	LF cable, length 11.48 ft (3.5 m)
CABLF40	LF cable, length 13.12 ft (4.0 m)
CABLF45	LF cable, length 14.76 ft (4.5 m)
CABLF50	LF cable, length 16.4 ft (5.0 m)
CABLF55	LF cable, length 18.04 ft (5.5 m)
CABLF60	LF cable, length 19.69 ft (6.0 m)
CABLF65	LF cable, length 21.33 ft (6.5 m)

Type	Description
CABLF70	LF cable, length 22.97 ft (7.0 m)
CABLF75	LF cable, length 24.61 ft (7.5 m)
CABLF80	LF cable, length 26.25 ft (8.0 m)
CABLF85	LF cable, length 27.88 ft (8.5 m)
CABLF90	LF cable, length 29.53 ft (9.0 m)
CABLF95	LF cable, length 31.17 ft (9.5 m)
CABLF100	LF cable, length 32.81 ft (10.0 m)
CABLF105	LF cable, length 34.45 ft (10.5 m)
CABLF110	LF cable, length 36.09 ft (11 m)
CABLF120	LF cable, length 39.37 ft (12 m)
CABLF130	LF cable, length 42.65 ft (13 m)
CABLF140	LF cable, length 45.93 ft (14 m)
CABLF150	LF cable, length 49.21 ft (15 m)

Type	Description
CABLE05A	Standard 33C cable*, length 1.64 ft (0.5 m)
CABLE10A	Standard 33C cable*, length 3.28 ft (1.0 m)
CABLE15A	Standard 33C cable*, length 5 ft (1.5 m)
CABLE20A	Standard 33C cable*, length 6.65 ft (2.0 m)
CABLE25A	Standard 33C cable*, length 8.2 ft (2.5 m)
CABLE30A	Standard 33C cable*, length 9.84 ft (3.0 m)
CABLE35A	Standard 33C cable*, length 11.48 ft (3.5 m)
CABLE40A	Standard 33C cable*, length 13.12 ft (4.0 m)
CABLE45A	Standard 33C cable*, length 14.76 ft (4.5 m)
CABLE50A	Standard 33C cable*, length 16.4 ft (5.0 m)

* Normal friction

Cable accessories

Ball-joint / Cable clamp

An extra for all VETUS push-pull cables.

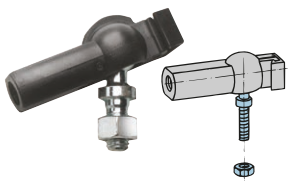

Ball-joint

KOGELGEWR

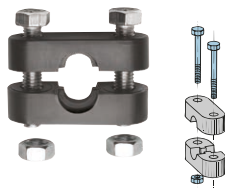

Cable clamp

KABELKL

Type	Description
KABELKL	Cable clamp for cables type 33 and LF
KOGELGEWR	Ball-joint for cables type 33 and LF

Shut-off control

Type DC

Type DC is corrosion resistant and easy to install (horizontally or vertically) and can be used with VETUS push-pull cables. Comes with a 30° mounting bracket.



DC

Type	Description
DC	Cable pull handle type DC

Dual station units type DS

Type DS combines the action of a single lever control from either of 2 command stations, providing a single output to the engine throttle or gearbox lever. 2 Dual station units are needed per engine (type DS-UNIT for the gearbox and type DS-KITF for the throttle).

DS-kit throttle

(only suitable for throttle control by pulling).



DSKITF

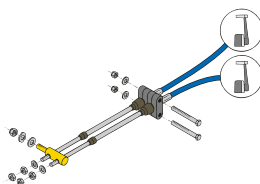

Type	Description
DSKITF	Dual station unit type DS, for throttle
DS	Dual station unit type DS, for gearbox

DS-unit (gearbox)

DS

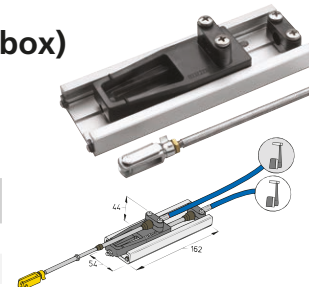

FLEXIBLE ENGINE MOUNTS

The torque of an engine is one of the deciding factors for determination of the load applied to the engine mounts. When more powerful engines are installed, it is important to use the following formula to define the load per support in kg (4 supporting points).

$$\frac{\text{engine weight in kg}}{\text{number of supports}} + \frac{\text{kW} \times 487 \times \text{reduction of gearbox}}{\text{engine revs/min.} \times \text{centre to centre spacing in metres of the longitudinal engine bearers}} = \text{max. load per support in kg}$$

Type K25V and K35V

For small engines and generator sets with 1 or 2 cylinders

These flexible mounts contain a special rubber compound with excellent vibration damping properties. They are suitable for marine engines in the power range between 4 and 15 kW (6-20 hp).



KSTEUN25V



KSTEUN35V

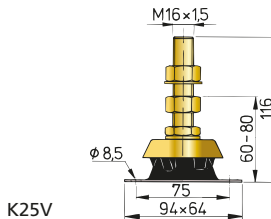

K25V

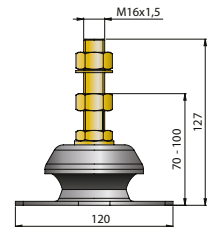

K35V

Type K40A

For 3-cylinder marine diesel engines

Type K40 has a relatively soft, rubber compound which fulfills the requirements of light-weight vessels with a modern 3-cylinder marine diesel engine. The rubber elements create optimum vibration dampening. Type KSTEUN40 features internal buffers which limit the engine movements when started or stopped. It is also secured against overload and shearing off.



KSTEUN40A

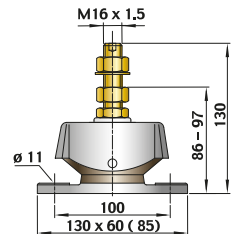

Type K

For smaller engines up to ± 60 kW (80 hp)

This type is suitable for smaller engines up to approximately 60 kW (80 hp).

KSTEUN50V

KSTEUN75V

KSTEUN80V

KSTEUN100V

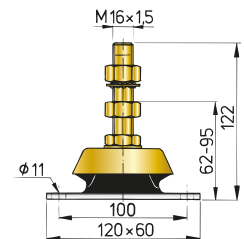

Type	Stiffness ratio			Min. load lbs (kg)	Min. compression inches (mm)	Max. load lbs (kg)	Max. compression inches (mm)	Hardness in ° Shore
	vertical	athwart ships	fore and aft					
KSTEUN25V	1	1,4	1,4	33.07 (15)	1/16 (1,3)	55 (25)	1/8 (3)	45
KSTEUN35V	1	1,4	1,4	33.07 (15)	1/16 (1,3)	66 (30)	1/4 (7)	45
KSTEUN40A	1	1	2,4	55.12 (25)	3/16 (5)	88 (40)	5/16 (8)	50
KSTEUN50V	1	0,75	2,5	55.12 (25)	1/16 (2)	110 (50)	3/16 (4)	45
KSTEUN75V	1	0,75	2,5	83.78 (38)	1/16 (2)	165 (75)	3/16 (4)	55
KSTEUN80V	1	0,75	2,5	88.18 (40)	1/16 (2)	176 (80)	3/16 (4)	60
KSTEUN100V	1	0,75	2,5	110.23 (50)	1/16 (2)	220 (100)	3/16 (4)	65

FLEXIBLE ENGINE MOUNTS

Type MITSTEUN

For marine diesel engines with 18 up to 26 kW (25-35 hp)

This hydro-damper is a combination of a conventional rubber-metal damper and a hydraulic shock absorber. Its reduction of vibration and noise is truly amazing. The maximum static load per support is 132 lbs (60 kg) and the maximum thrust 110 lbs (50 kg).

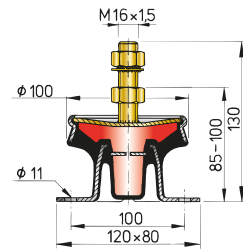

MITSTEUN

Type HY

For heavy-weight engines with 4 or more cylinders

This type is extremely suitable for application with marine diesel engines in the power range between 30 and 125 kW (40-170 hp), by virtue of a low stiffness combined with high stiffness in the longitudinal direction.

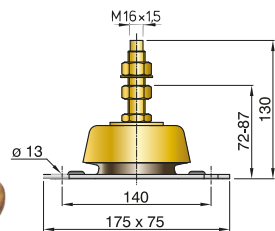
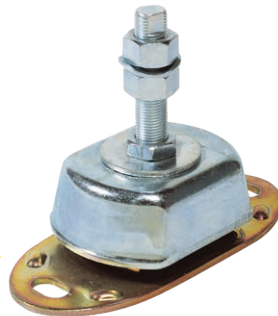

HY100

HY150

HY230

Type LMX

For marine diesel engines with 70 up to 350 kW (95-480 hp)

This type has been designed with particular regard to the power to weight ratio of modern diesel engines. The weight of an engine, in comparison to its thrust, has become lower and lower. Type LMX guarantees optimum damping of vibrations, even at idling revs. It has a very high horizontal and aft stiffness which allows the acceptance of considerable thrust. The cushioning of vibrations in horizontal direction athwart-ships is of equal excellence.

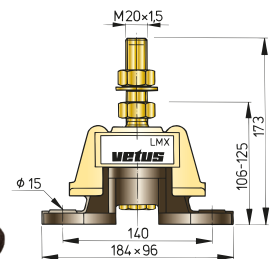
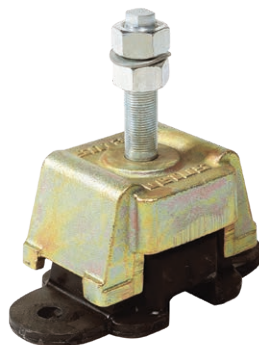

LMX140

LMX210

LMX340

LMX500

Type	Stiffness ratio			Min. load lbs (kg)	Min. compression inches (mm)	Max. load lbs (kg)	Max. compression inches (mm)	Hardness in ° Shore
	vertical	athwart ships	fore and aft					
MITSTEUN	1	1	1	56 (25)	1/16 (1,3)	148 (67)	3/16 (4)	45
HY100	1	1,2	3,5	88 (40)	1/16 (2)	220 (100)	3/16 (5)	40
HY150	1	1,2	3,5	132 (60)	1/16 (2)	330 (150)	3/16 (5)	50
HY230	1	1,2	3,5	202 (92)	1/16 (2)	507 (230)	3/16 (5)	60
LMX140	1	1	7	187 (85)	1/8 (3)	309 (140)	3/16 (5)	35
LMX210	1	1	7	276 (125)	1/8 (3)	463 (210)	3/16 (5)	45
LMX340	1	1	7	452 (205)	1/8 (3)	750 (340)	3/16 (5)	55
LMX500	1	1	7	661 (300)	1/8 (3)	1102 (500)	3/16 (5)	65

COOLING WATER STRAINERS

All VETUS cooling water strainers have a transparent cover for easy inspection of the filter without dismantling. Cleaning of the filter seldom needs to be done but can be easily and quickly achieved.

Typical installation

VETUS advises to install the water strainer always above the waterline. Only type CWS, the metal filter, can be installed below the waterline. Always install a sea-cock behind the inlet water scoop.

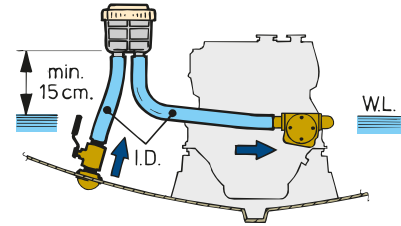

Type FTR140

This water strainer is available with 3 different hose connection diameters. See page 55 for water strainer install kit.

Specifications

- Housing of Polypropylene GF
- Filter element of HD Polyethylene
- Cover of Styrol/Acrylonitrile SAN

Type	Internal hose Ø		Recommended input
	mm	inches	l/min.
FTR140/13	12,7	1/2	23
FTR140/16	15,9	5/8	35
FTR140/19	19,1	3/4	51

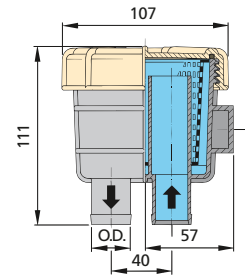

FTR140

Type FILTER150

This water strainer is suitable for Ø 1 1/8" (28,5 mm) hoses.

Specifications

- Housing of Polypropylene GF
- Filter element of Polyamide
- Cover of A.B.S.

Type	Internal hose Ø		Recommended input
	mm	inches	l/min.
FILTER150	28,5	1 1/8	114

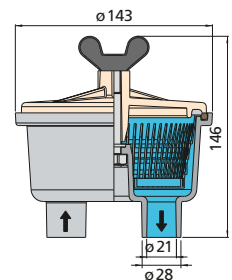

FILTER150

Type FTR330

This water strainer is available for 6 different hose connections. See page 55 for water strainer install kit.

Specifications

- Housing of polypropylene GF
- Filter element of HD Polyethylene
- Cover of Styrol/Acrylonitrile SAN

Type	Internal hose Ø		Recommended input
	mm	inches	l/min.
FTR330/13	12,7	1/2	23
FTR330/16	15,9	5/8	35
FTR330/19	19,1	3/4	51
FTR330/25	25,4	1	91
FTR330/32	31,8	1 1/4	143
FTR330/38	38,1	1 1/2	200

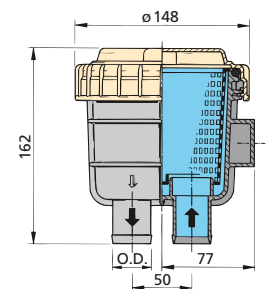

FTR330

COOLING WATER STRAINERS

Type FTR470

Easy mounting with 360° rotating wall bracket

This strainer is supplied with a rotating stainless steel (AISI 316) wall bracket for easy alignment of the hose connections and clamping it securely in place. This eliminates the need for back-bolting and dramatically simplifies the mounting process.

Specifications

- Housing of Polypropylene GF
- Filter element of HD Polyethylene
- Cover of Polypropylene GF/Polycarbonate

See page 55 for the water strainer installation kit.

Type	Internal hose Ø		Recommended input
	mm	inches	l/min.
FTR470/13	12,7	½	23
FTR470/16	15,9	5/8	35
FTR470/19	19,1	¾	51
FTR470/25	25,4	1	91
FTR470/32	31,8	1¼	143
FTR470/38	38,1	1½	200



FTR470

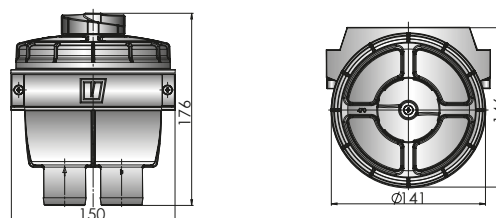

Type FTR33038M

This water strainer has the standard housing of the FTR330 made of the Navidurin® material. De lid is replaced by a aluminum version. Tested until 6 bar and is suitable for use under the waterline. Hose connection Ø 1½" (38,1 mm)

Specifications

- NAVIDURIN® material
- Easy inspection without dismanteling
- Easily removable cover
- Robust and durable filter

Type	Internal hose Ø		Recommended input
	mm	inches	l/min.
FTR33038M	38,1	1½	200

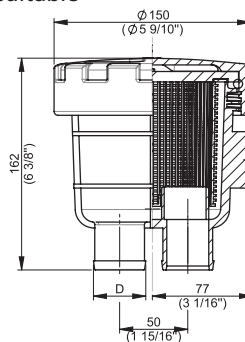

FTR33038M

Type FTR1320

This type is provided with adjustable stainless steel (AISI 316) brackets for bulkhead mounting and is available with 3 different threaded connection diameters. Hose pillars are not supplied as standard. They can be found on page 378 of this catalogue.

Specifications

- Housing of Polypropylene GF
- Filter element Polyethylene
- Cover of A.B.S.

Type	D	Internal hose Ø		recommended input l/min.
		mm	inches	
FTR1320/38	G 1½	38	1½	205
FTR1320/50	G 2	50	2	365
FTR1320/63	G 2½	63	2½	570

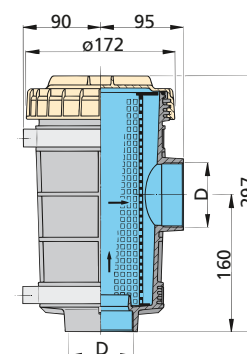

FTR1320

COOLING WATER STRAINERS

Type FTR1900

This type has 2 different threaded connection diameters and comes with adjustable stainless steel (AISI 316) mounting brackets for bulkhead installation. Hose pillars are not supplied as standard. They can be found on page 378 of this catalogue.

Specifications

- Housing of Polypropylene
- Stainless steel (AISI 316) filter element
- Acrylic cover

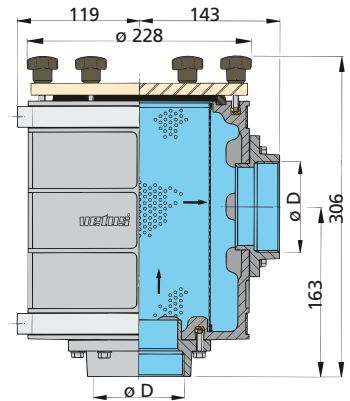

FTR1900

Type	D	Internal hose Ø		recommended input l/min.
		mm	inches	
FTR1900/63	G 2½	63	2½	570
FTR1900/76	G 3	76	3	820

New metal filter - CWS series

VETUS introduces a new metal filter type CWS. For installations where the cooling water strainer must be mounted close to or below the waterline and for commercial applications, these nickel plated bronze are an ideal solution. The cover is removable with one screw. Tested up to 7 bar overpressure.

This filter is available in 3 different sizes, with threaded connections of G1, G1 ¼ and G1 ½. Matching V-Quipment hose connections are available separately, see table below for item numbers.

Specifications

- Housing of nickel plated bronze
- Cover of polycarbonate
- Filter element of stainless steel (AISI 316)
- Mounting bracket of nickel plated bronze
- Can be mounted near or below the waterline
- V-Quipment hose connections available separately, see also page 374



CWS

Type	Matching hose connector			Hose size	Recommended input (l/min.)
	Bronze	Brass	Brass		
CWS1	HPB1	HPM1	SLP125	25,4 mm - 1 inch	91
CWS1¼	HPB1¼	HPM1¼	SLP1¼/438	31,8 mm - 1¼ inch	143
CWS1½	HPB1½	HPM1½	SLP1½/432	38,1 mm - 1½ inch	200

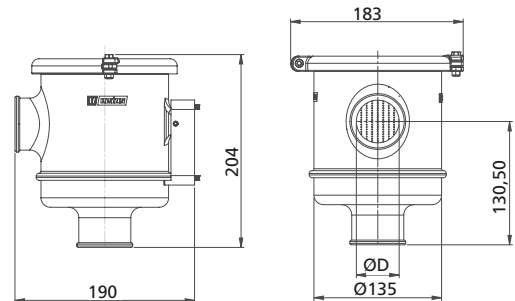

Type FTR525

This water strainer has G 1½ threaded connections. A set of stainless steel (AISI 316) mounting brackets can be supplied as an option. Hose pillars are not supplied as standard. They can be found on page 378 of this catalogue.

Specifications

- Stainless steel (AISI 316) housing and filter element
- Acrylic cover

Type	D	Internal hose Ø		recommended input l/min.
		mm	inches	
FTR525	G 1½	38	1½	205

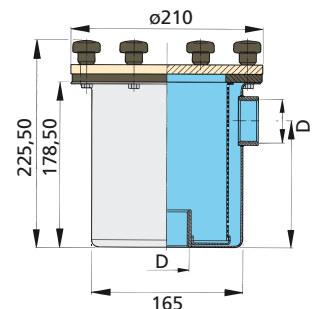

FTR525

ACCESSORIES

Water strainer kit

Kit to install any VETUS cooling water strainer with either 1/2, 3/4, 1, 1 1/4 or 1 1/2" (13, 19, 25 or 32 mm) hose connection.

The kit consists of: 2 mtr Drinking water hose, 1 pc Ball valve, 4 pcs Hose clamps, 1 pc Waterscoop, 1 pc Hose pillar.



WKIT330..

Type	Hose connection	Thread connection
WKIT33013	1/2"	1/2"
WKIT33016	5/8"	3/4"
WKIT33019	3/4"	3/4"
WKIT33025	1"	1"
WKIT33032	1 1/4"	1 1/4"
WKIT33038	1 1/2"	1 1/2"

Connection parts for water strainers, type CONN330

Easy interconnecting

With these connection parts 2 water strainers type 330/32 or 470/32 can be interconnected with a maximum capacity of 460 L/min.

Type 470 cannot be rotated when the kit is used.



CONN330

Type	Description
CONN330	Connection kit for two FTR330/32 strainers

Bilge water/oil separator, type BISEP

Collecting and retaining oil and grease from bilge water

This VETUS separator has a replaceable filter element with a capacity of 600 grams. It can remove 95% of oil in the bilge water. The bilge pump used in combination with this filter should have a maximum capacity of 25 litres/min.

The BISEP19 is now supplied with new filter elements. These filter discs are made from a different material, have a larger capacity (up to 600 grams of oil) and filter up to 15.000 litres of water, outperforming the previous filter by 87%!

The new filter elements are reusable and made entirely from waste fibres. They absorb oils and oil-based contamination, thus removing oils, oil film and fats from the bilge water.

The absorbed oil can be collected and recycled, after which the filter can be washed and reused.

Specifications

- Connections for Ø 3/4" (19 mm) hoses
- Dimensions l 5 13/16" x w 5 15/16" x h 6 3/8" (148 x 150 x 162 mm)

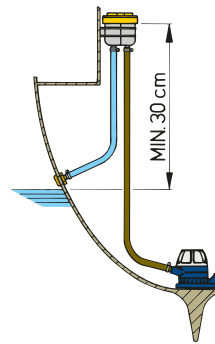

BISEP19

Type	Description
BISEP19	Bilge water/oil separator
BISEP19F2	Replacement element for bilge water/oil filter BISEP19, set of 15 pieces

Cooling water hose, type MWHOSE

For all cooling fluids

Type MWHOSE is made of EPDM rubber with synthetic fabric and spiralled steel reinforcement. Suitable for cooling water, both suction and pressure (max. 36,2 psi (2,5 bar)), salt and fresh water. Temperature resistant between -22°F (-30°C) and + 248°F (120°C).

Unlike lower quality un-reinforced hoses, MWHOSE will not kink or fold shut, thereby preventing a major cause of low seawater flow to the engine cooling system and consequent damage to the impeller and the exhaust system. Similar benefits accrue from the use of this hose for cockpit drains and other critical water connections.

For a complete overview, specifications and dimensions of hoses see page 404.

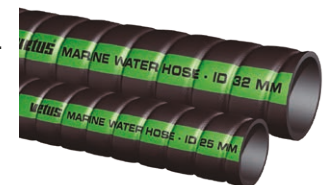

MWHOSE

SOUND INSULATION MATERIALS

VETUS sound insulation, discover peace and quiet!

VETUS sound insulation is a versatile range of materials especially developed for marine applications. These products are liquid tight, fire resistant and consist of the highest quality insulation foams. VETUS' product lines are based on 2 insulation foams, Sonitech and Prometech, and are available in various sheet thicknesses. The sound absorption coefficients of these base foam materials are tested according to ISO 10534.

Base materials

The range is built around a number of base materials. Various compositions of these base materials form the four main product lines, which are available in various sheet thicknesses. In the selection table below the possible combinations are presented, to help you select the correct product for your application.

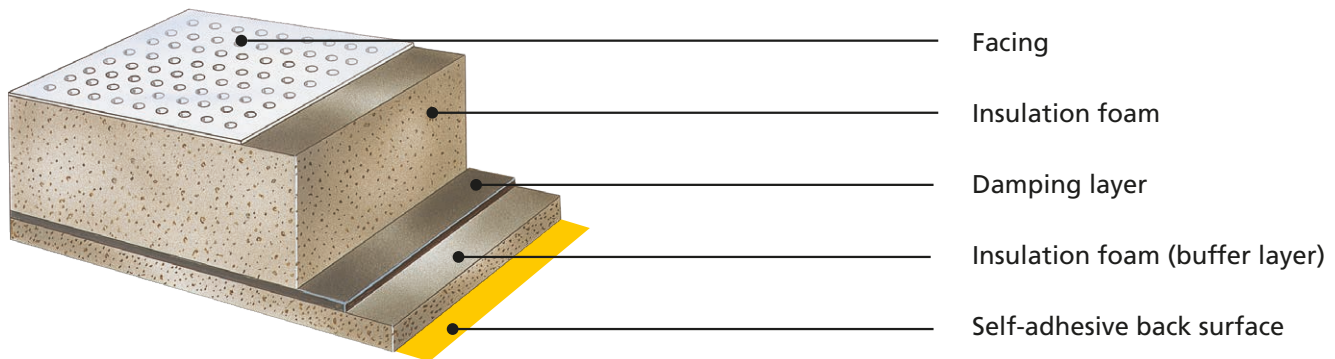

Sound insulation

The sound absorption coefficients of both base foam materials are tested according to ISO 10534.

Guaranteed fire resistance; Class 0

The 'BS476 Class 0' fire resistance rating is the most demanding rating on the market today. To achieve class 0 the product must achieve:

- BS476 part 7, Surface spread of flame, Class 1
- BS476 part 6, Fire propagation, Index I <12 and i1 < 6

This means that the material does not spread flames and limits the amount of heat released from the surface during a fire.

Range		Sonitech light				Sonitech single				Prometech single				Prometech double							
Product code (All sheets are 600 x 1000 mm)		ST020A	ST040A	ST020W	ST040W	ST135A	ST145A	ST135W	ST145W	PT112A	PT135A	PT145A	PT112W	PT135W	PT145W	PT225S	PT245S	PT260S	PT225W	PT245W	PT260W
Material	Sonitech	•	•	•	•	•	•	•	•												
	Prometech									•	•	•	•	•	•	•	•	•	•	•	•
	Number of damping layers	0	0	0	0	1	1	1	1	1	1	1	1	1	1	2	2	2	2	2	2
	Total thickness (inch)	25/32	1 37/64	25/32	1 37/64	1 3/8	1 49/64	1 3/8	1 49/64	1/2	1 3/8	1 49/64	1/2	1 3/8	1 49/64	1	1 49/64	1 49/64	1	1 49/64	1 49/64
Facing	Aluminium	•	•			•	•			•	•	•									
	White foil			•	•																
	Glass cloth Silver															•	•	•			
	Glass cloth White												•	•	•				•	•	•
Back	Self-adhesive	•	•	•	•	•	•	•	•	•	•	•	•	•	•	•	•	•	•	•	•
Weight	(lbs)	0.9	1.5	0.9	1.5	7.9	8.4	7.9	8.4	7.9	10.8	11.9	7.9	10.8	11.9	15.9	17.2	20.3	15.9	17.2	20.3
Class 0	Fire resistant									•	•	•	•	•	•	•	•	•	•	•	•

SOUND INSULATION MATERIALS

VETUS offers four product lines, based on two insulation foams; Sonitech and Prometech. Both foams have excellent sound reducing capabilities and are fire resistant. Prometech is rated to BS476 Class 0 fire resistance.

All sheets measure 39³/₈" (100 cm) x 25⁵/₈" (60 cm) and are supplied with a self-adhesive backing for quick and easy installation. The modified acrylic adhesive has high initial tack and adhesion of 1000 N/m to steel (ATM.1-PSTC.1).



Prometech double

Ultimate sound insulation and safety

This line is designed to absorb as much sound as possible. It is the top of the range product line with double damping layers.



Prometech single

Excellent sound insulation, highest safety level

This product has good sound reducing capabilities and the highest level of safety. Ideal for applications where space is limited.

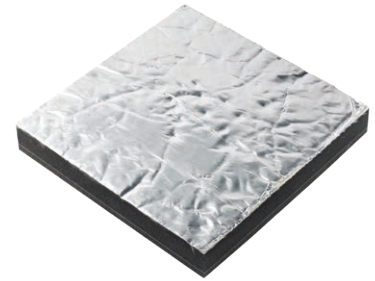

Sonitech single

Good sound insulation capabilities

These sheets have a single damping layer resulting in good sound insulation. It gives excellent results at reasonable prices.

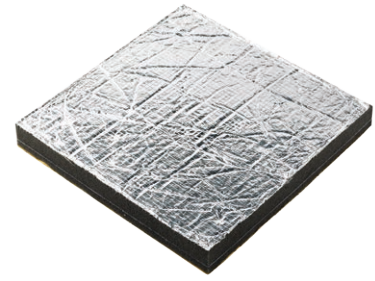

Sonitech light

Flexible and light-weight sheet

This product has efficient sound insulation and is ideal for use when cost or space is the prime concern.

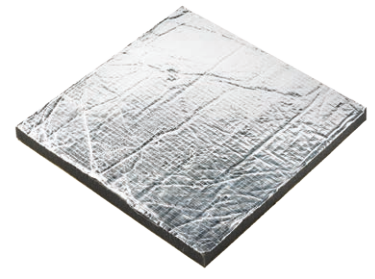

SOUND INSULATION MATERIALS

Installation guidelines

Preparing the engine room

Sound is like water and until the last gap is closed, it will find a way out of the engine room. Therefore it is important to cover as much of the surface in the engine room as possible and to close all possible leaks. Any small gaps or holes in, between or under the bulkheads should be filled with flexible sealant, foam or other material. When the 'engine room' is in direct contact with the bilge or other spaces that run through the boat, it is recommended to build bulkheads or a box around the engine.

Fitting the sheets

While fitting the sheets, work around obstacles by cutting the sheet into the right shape and try to fit the puzzle as neatly as possible before actually sticking the sheets in place. Note that tanks tend to amplify noise. When a tank is in the same space as the engine, cover the tank in insulation sheets or build a bulkhead between them.

Hatches and air intakes

Hatches and air intakes may leak noise. Hatches can be sound proofed by using an insulation tape between the touching surfaces. Air intakes however are more difficult to insulate, as the engine needs air for combustion and cooling. Creating a labyrinth or installing a special damper will generally solve the noise leak without choking the engine.

Sound deadening sheet type GF140S

Absorbing both high and low frequency noise and vibration

These modern light-weight sound deadening sheets are self-adhesive and have an aluminium face layer.

Specifications

- Dimensions 3.9 ft (120 cm) x 2.6 ft (80 cm) x 1⁹/₁₆" (40 mm)
- Weight per plate 12.35 lbs (5,6 kg)
- Temperature resistance up to 284°F (140°C)

Type	Description
GF140S	Sound-deadening glass wool sheet



GF140S

Sound deadening sheet type PU130S

Ideal for smaller engine installations

These sound deadening sheets have excellent noise and vibration reducing qualities and come in packs of 4 sheets.

Specifications

- Dimensions 3.3 ft (100 cm) x 1.6 ft (50 cm) x 1³/₁₆" (30 mm)
- Weight per plate 3.31 lbs (1,5 kg)
- Temperature resistance -22°F (-30°C) to + 194°F (90°C)

Type	Description
PU130S	Sound-deadening sheets (pack of 4 sheets)

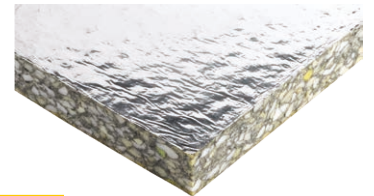

PU130S

SOUND INSULATION MATERIALS

Anti-reverberation material type ARM

Reduces structure borne sounds

Type ARM specifically reduces structure-borne sounds caused by, for example, the ship's propeller. These plates are suitable for steel and aluminium structures.

Specifications

- Plate dimensions 3.3 ft (100 cm) x 3.9 ft (120 cm) x $\frac{3}{16}$ " (4 mm)
- Weight per plate 18 lbs (8 kg)
- Temperature resistance -14°F (-10° C) to +194°F (90°C)



ARM10X12

Type	Description
ARM10X12	Anti-reverberation plate

Self-adhesive tape

Providing a neat and professional finish

When installing any VETUS sound insulation sheet, we recommend using these self-adhesive tapes to cover the joints.

Specifications

- Come in rolls of 98.5 ft (30 m) long and 2" (50 mm) wide
- Available in the colours grey (TAPEG30), white (TAPEW30) and aluminium (TAPEA30)



TAPE

Type	Description
TAPEG30	Self-adhesive tape, grey
TAPEW30	Self-adhesive tape, white
TAPEA30	Self-adhesive tape, aluminium

Glass cloth tape

For use with glass cloth faced insulation sheets

This tape is perfect for sound insulation applications, requiring strength, flexibility and resistance to heat. Especially suitable for use with the VETUS glass fibre faced sound isolation sheets.

Available in a 164' x 2" (50 m x 50 mm) size.



TAPEGF50

Type	Description
TAPEGF50	Self-adhesive tape, glass fibre



SOUND INSULATION MATERIALS

Rosettes

For easy installation of heavy sheets

These fixing rosettes made of Polypropylene are ideal for easy installing of heavy sheets. They come in packs of 15 pieces (screw not supplied).

Type	Description
FIXP	Ceiling rosette for fastening sound insulation sheets

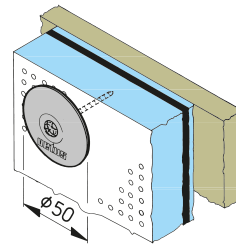

FIXP

Mounting bracket type MBSET

For easy fixing of ancillary equipment

With this stainless steel (AISI 316) mounting bracket you easily fix cooling water strainers, no-smell and fuel filters on sound insulation materials up to 1⁹/₁₆" (40 mm) thick. It is supplied with bolts, washers and self-locking nuts. Fixings to mount the bracket are not included.

Type	Description
MBSET01	Mounting bracket set M5 x 35 for ASD38V, ASD38H
MBSET02	Mounting bracket set for ASDV/H, AIRVENTV/H
MBSET03	Mounting bracket set for FTR140, WS180, WS720, NSFS
MBSET04	Mounting bracket set for fuel filters 704, 709 & 712
MBSET05	Mounting bracket set for FTR330, FILTER150, NSF



MBSET01

MBSET02

MBSET03

MBSET04

MBSET05

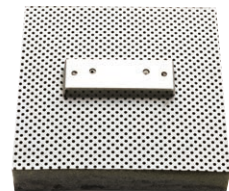

STERN GEAR SYSTEMS

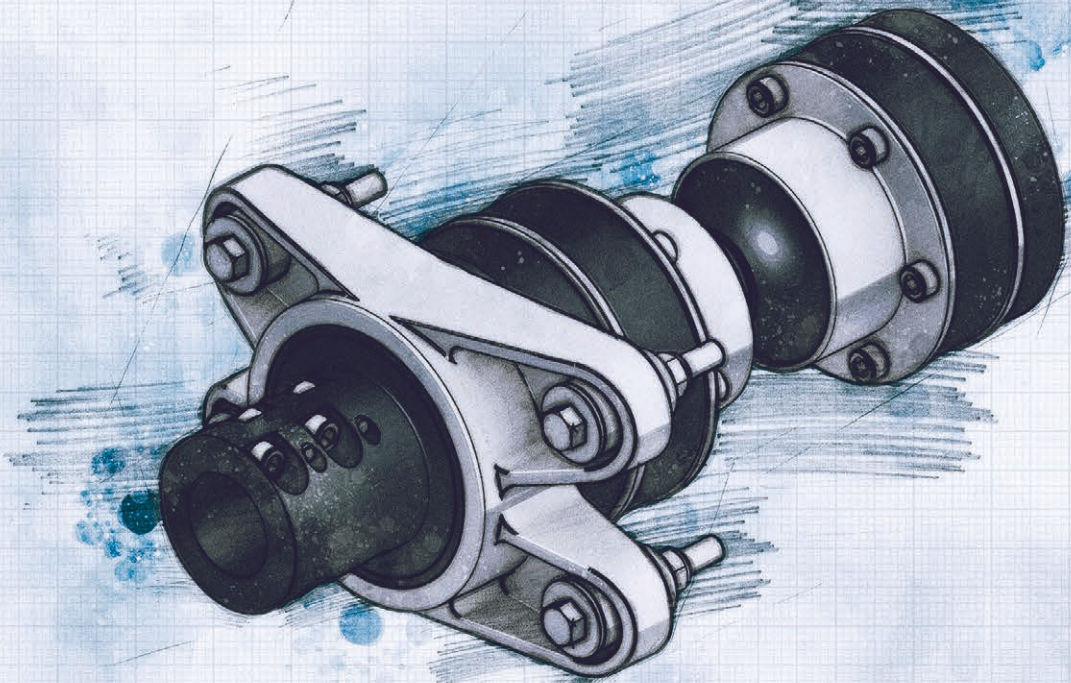

Overview VETUS stern gear systems

Stern gear see page 65



Flexible couplings see page 66



Constant velocity joint couplings see page 70



Adapter flanges see page 71



Water lubricated stern gear see page 72

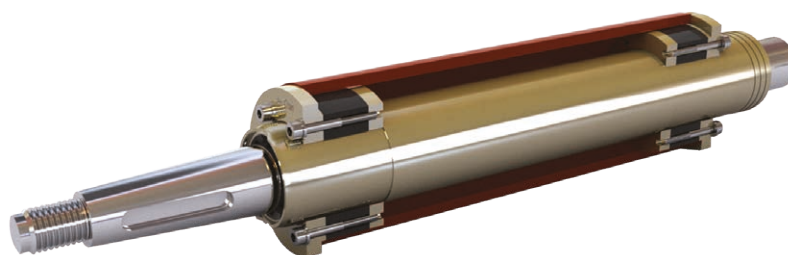

Propellers see page 78



Cutless bearings see page 80



WHY VETUS STERN GEAR SYSTEMS?

The stern gear is one of the most important systems in a boat and deserves special attention. After all, a well-calculated, manufactured and installed propeller shaft system can greatly enhance the performance and reliability of your boat. Our engineers, responsible for propulsion systems, feel like they represent the heart of the boat. They work with only the best quality propellers, propeller shafts, stern tubes and couplings to design perfectly tuned systems.

The desired boat speed, waterline length, hull shape and weight are the key factors to determine the perfect engine and gear box combination for a boat. Stern gear transfers the power of the engine to the water. The determination of the optimum propeller is specialized work that has to be carried out with sophisticated propeller calculation programmes and needs above all, experience.

VETUS has many years of experience with stern gear and offers a wide range of products which are environmentally friendly and which increase comfort on board. Water-lubricated propeller shafts eliminate the need for oil or grease while flexible couplings absorb deviations in the alignment of the propeller shaft and ensure that vibration transferred from the propeller shaft system to the boat is kept to a minimum.

A well-designed stern gear system needs

- A dynamically balanced propeller to prevent vibration, resonance and cavitation
- A propeller shaft to transmit the engine power to the propeller
- Rubber bearings to ensure that vibration and noise are reduced to a minimum
- A stern tube and reliable stern gland
- A coupling to make alignment of the shaft and engine easier

Good reasons to choose a VETUS stern gear system

- VETUS offers free calculation of the correct propeller size using a special computer program
- VETUS' large stock of standard high quality propellers in various sizes, pitches and blade areas
- VETUS provides in-house emergency repairs and modifies the bore and taper of stock propellers if necessary
- VETUS uses high quality corrosion-free materials designed for long life
- VETUS supplies a complete system, using both standard and custom made products
- VETUS offers various stern tube systems for shafts from 1" to 2 ³/₈" (25 to 60 mm) diameter
- VETUS offers various flexible couplings which significantly reduce vibration
- VETUS shaft assemblies protect the environment; water lubrication means no oil or grease pollution



WATER LUBRICATED STERN GEAR

Water lubricated stern gear for wooden, steel or polyester (G.R.P.) vessels

VETUS is able to deliver stern gear assemblies directly from stock. Machining, threading and keyway cutting have all been taken care of, so easy installation is guaranteed.

Specifications

- All VETUS propeller shafts are made of stainless steel type Duplex 1-4462, corrosion-free and with excellent running properties in rubber bearings
- Dual shaft seal (eliminating the need for a stuffing box)
- A propeller nut with integrated zinc anode is supplied as standard
- Water lubricated

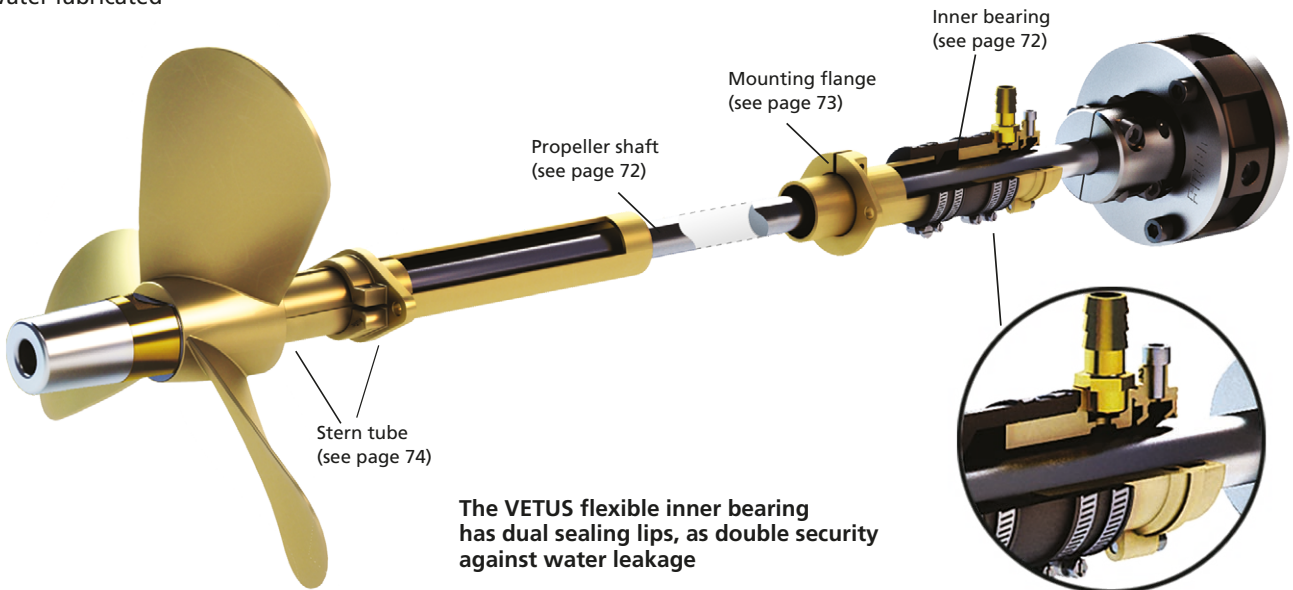

The VETUS flexible inner bearing has dual sealing lips, as double security against water leakage

Why Duplex 1-4462 instead of AISI 316

All VETUS propeller shafts are made of stainless steel type "Duplex 1-4462". In comparison with stainless steel materials like AISI 316 and Aquamet 17 or 22, the corrosion resistance of "Duplex 1-4462" is much greater. In addition the tensile strength of "Duplex 1-4462" is about 30% greater than AISI 316 and its hardness is approximately 40% higher. It is precisely this high degree of hardness, which gives "Duplex 1-4462" its excellent running properties in rubber bearings.

Example

Imagine, you have a shaft with a maximum shaft speed of 1400 r.p.m. and a diameter of $1\frac{3}{16}$ " (30 mm). The diagram shows (blue line) that the maximum distance between 2 bearings amounts to 5 ft 3" (1600 mm). If you have a shaft of e.g. 4 ft $11\frac{1}{16}$ " (1500 mm) length, then one rubber bearing will be sufficient. Should you have a shaft of 6 ft $6\frac{47}{64}$ " (2000 mm) length, in this case 2 rubber bearings have to be used. For shafts with a length of 10 ft 6" (3200 mm) or longer, 3 bearings are needed.

Depending on shaft length, diameter and speed of rotation (rpm), 1, 2 or 3 cutless bearings must be installed.

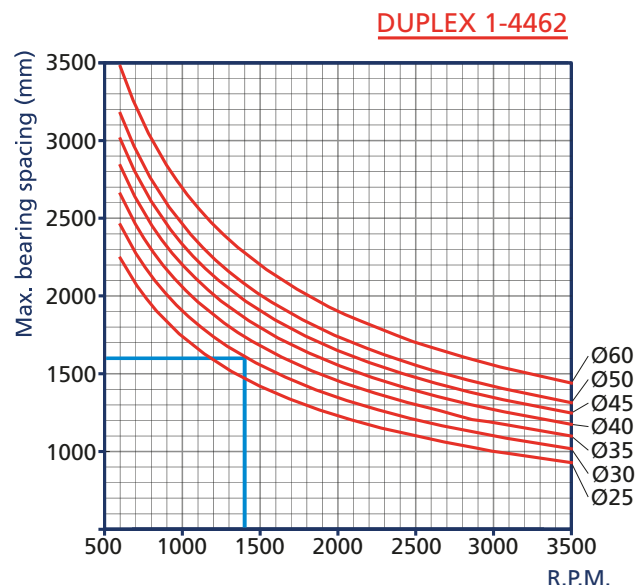
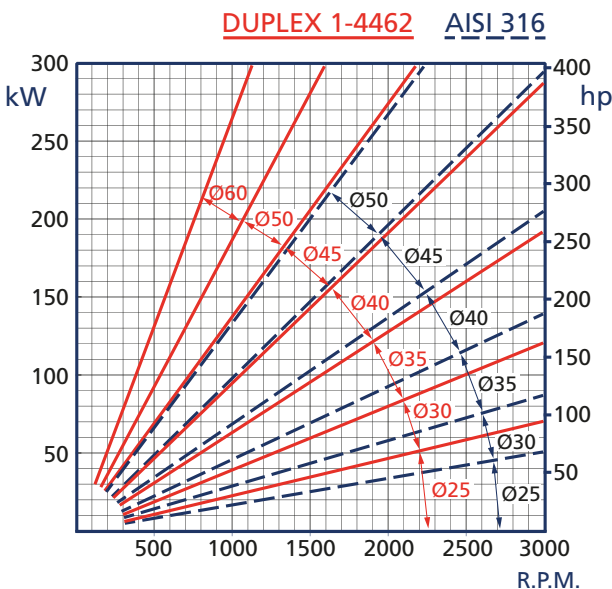

FLEXIBLE COUPLINGS

VETUS offers a variety of solutions to connect the propeller shaft to the engine. The flexible rubber element of the flexible coupling ensures low-noise vibration-free transmission, without backlash between the engine and the propeller shaft.

For smaller stern gear installations up to 1³/₁₆" (30 mm), depending on the space available in the engine room, you can either choose the Bullflex, Combiflex, Uniflex type 13 or the KO5. These couplings all permit a misalignment of 2°. Only the KO5 is suitable for V-drives. For stern gear installations up to 2³/₄" (70 mm), you can choose between Bullflex and Uniflex type 16.

Last but not least, VETUS offers the VDR. This double acting constant velocity joint comes with a thrust bearing. The VDR is used when considerable misalignment angles need to be overcome.

Type COMBIFLEX

Optimum damping of torsional vibrations

The Combiflex coupling has been designed to ensure optimum damping of torsional vibrations, created by cycle irregularities especially at low engine revolutions. The Combiflex coupling is secured against shearing off, both axially and radially, thus ensuring safe transmission under all circumstances. The Combiflex coupling also provides excellent alignment of the propeller shaft. Aligning the engine and propeller shaft can be a rather time consuming affair, however the Combiflex will remain perfectly centred onto the gearbox flange, even if the shaft has a misalignment of 2°. The parallel clamping hub ensures easy installation and probably even more importantly, easy dismantling of the shaft assembly.

Available for shafts of Ø 1" (25 mm) or 1³/₁₆" (30 mm). Comes with a 4" flange to fit most common gearbox models.

For specifications, please see table on the next page.

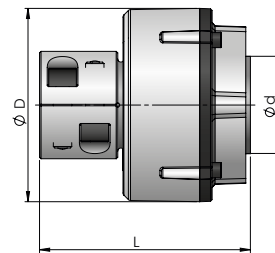

COMFL

Type Uniflex

Exact alignment and concentric installation of propeller shaft

Couplings of type Uniflex permit a misalignment of 2°. Uniflex couplings will centre the shaft on the gearbox by means of a conical clamping hub and are an ideal flexible coupling between a propeller shaft with a self-aligning bearing and an engine on flexible supports. These couplings are axially and radially secured against shearing off. When the propeller shaft is connected to the engine at an angle of 2°, the maximum admissible number of revolutions is 1.500 r.p.m. on the shaft.

Specifications Uniflex type 13 and 16

- With cylindrical bore
- Clamping hub for shafts with a diameter of 2⁵/₃₂", 1" and 1³/₁₆" (20, 25 and 30 mm) (type 13), and 1³/₁₆", 1³/₈" or 1⁹/₁₆" (30, 35 or 40 mm) for type 16
- 4" Connection (type 13) and/or 5" (type 16) for Hurth, Velvet, TD, ZF, PRM and other makes
- Not suitable for V-Drives

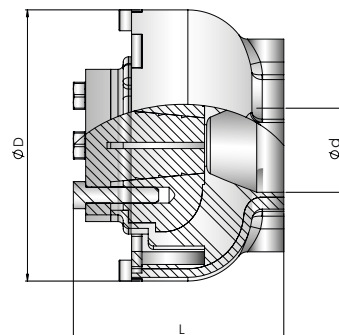

UNIFL

FLEXIBLE COUPLINGS

Type KO5 (type 6)

100% Concentric fit

This flexible coupling has a special conical clamping hub and is suitable for V-drives.

Type 6 saves considerable installation time. It is pilot bored $\varnothing 20$ mm or with a cylindrical bore for $\varnothing 25$, 30 and 35 mm shaft.

Comes with 4 and 5" connectors for Hurth, Velvet, TD, ZF and PRM.



KO5

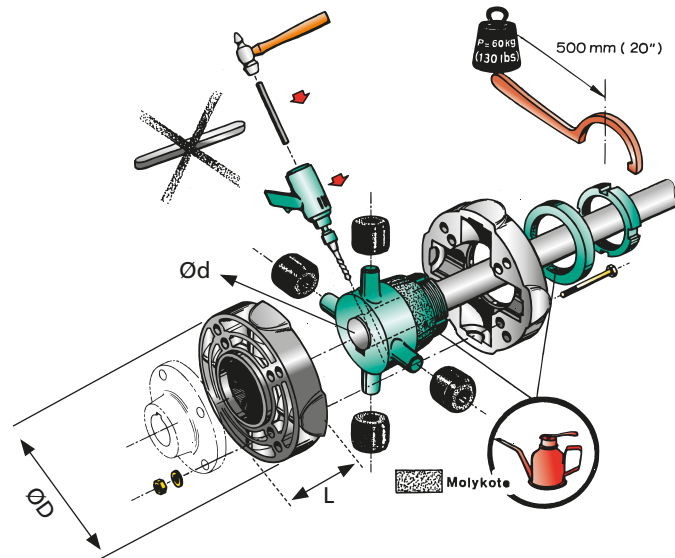

Specifications

Type	DIN 6270 B = pleasure craft. kW/100 r.p.m. on shaft (HP)	Example: at 1500 r.p.m. the max. admissible power is (DIN B)	DIN 6270 A = commercial craft. kW/100 r.p.m. on shaft (HP)	D inch (mm)	L inch (mm)	$\varnothing d$ (mm)	Weight lbs (kg)
COMFL1225	2,4 (3,2)	15 x 2,4 = 36 kW (48 hp)	1,7 (2,2)	4 $\frac{61}{64}$ (126)	5 $\frac{25}{64}$ (137)	25	7.7 (3,5)
COMFL1230	2,4 (3,2)	15 x 2,4 = 36 kW (48 hp)	1,7 (2,2)	4 $\frac{61}{64}$ (126)	5 $\frac{25}{64}$ (137)	30	7.1 (3,2)
KO51	3,9 (5,3)	15 x 3,9 = 58,5 kW (79,5 hp)	3,3 (4,5)	5 $\frac{25}{64}$ (137)	3 $\frac{5}{16}$ (84)	25	6.0 (2,7)
KO52	3,9 (5,3)	15 x 3,9 = 58,5 kW (79,5 hp)	3,3 (4,5)	5 $\frac{25}{64}$ (137)	3 $\frac{5}{16}$ (84)	30	6.0 (2,7)
KO53	3,9 (5,3)	15 x 3,9 = 58,5 kW (79,5 hp)	3,3 (4,5)	5 $\frac{25}{64}$ (137)	3 $\frac{5}{16}$ (84)	35	6.0 (2,7)
KO54 (type 6)	3,9 (5,3)	15 x 3,9 = 58,5 kW (79,5 hp)	3,3 (4,5)	5 $\frac{25}{64}$ (137)	3 $\frac{5}{16}$ (84)	20 Pilot	6.0 (2,7)
UNIFL1320	2,6 (3,6)	15 x 2,6 = 39 kW (53 hp)	1,8 (2,5)	5 $\frac{1}{8}$ (130)	3 $\frac{55}{64}$ (98)	20	5.3 (2,4)
UNIFL1325	2,6 (3,6)	15 x 2,6 = 39 kW (53 hp)	1,8 (2,5)	5 $\frac{1}{8}$ (130)	3 $\frac{55}{64}$ (98)	25	5.3 (2,4)
UNIFL1330	2,6 (3,6)	15 x 2,6 = 39 kW (53 hp)	1,8 (2,5)	5 $\frac{1}{8}$ (130)	3 $\frac{55}{64}$ (98)	30	5.3 (2,4)
UNIFL1630	5,2 (7,1)	15 x 5,2 = 79 kW (107 hp)	3,6 (5)	7 $\frac{53}{64}$ (199)	5 $\frac{5}{32}$ (131)	30	15.2 (6,9)
UNIFL1635	5,2 (7,1)	15 x 5,2 = 79 kW (107 hp)	3,6 (5)	7 $\frac{53}{64}$ (199)	5 $\frac{5}{32}$ (131)	35	15.2 (6,9)
UNIFL1640	5,2 (7,1)	15 x 5,2 = 79 kW (107 hp)	3,6 (5)	7 $\frac{53}{64}$ (199)	5 $\frac{5}{32}$ (131)	40	15.2 (6,9)

Bolt sets required to attach flexible coupling to gearbox drive flange

Type	Description
SET64	Set bolts for coupling type 6, for flange 4"
SET65	Set bolts for coupling type 6, for flange 5"
UNISSET4/5	Set studs and bolts (M10) for couplings Combiflex, Uniflex and Bullflex 1-8, for flange 4"/5"

FLEXIBLE COUPLINGS

Type Bullflex

Ensuring optimum damping of vibrations

The Bullflex is the answer to the increasing demand of greater boating comfort. It is especially designed to ensure optimum damping of vibrations. Torsional vibrations are smoothed out extremely efficiently by its very flexible rubber element, ensuring low-noise and vibration-free transmission without backlash between the engine and propeller shaft. Another strong characteristic is the excellent alignment of the propeller shaft. For the most popular Volvo, Yanmar and Kanzaki gearboxes special (also custom made) adapter flanges are available (see page 71).

Features

- Very high flexibility
- Secured against shearing off (axially and radially) ensuring safe transmission under all circumstances
- Misalignment of up to 2° permissible
- Excellent centring of the shaft, allowing high shaft revolutions
- Shaft remains centred even in reverse gear
- Possibility to remove the centring ring, in case two or more bearings are applied
- Built-in thrust damper reducing axial vibrations
- Non-tapered clamping hub for perfect centring and easy dismantling of the shaft assembly

Specifications

- Models 1, 2 and 4 have a 4" gearbox connection
- Models 8, 12 and 16 feature a 4 and 5" gearbox connection
- Model 32 is provided with 6 threaded M16 holes on a pitch circle diameter of Ø 4,75" (120,65 mm) enabling mounting of the couplings to most models of gearboxes (Hurth, Velvet, TD, ZF and P.R.M.)
- VETUS can also supply the required fastenings for installation of the Bullflex onto the gearbox.
This coupling is not suitable for V-Drives

For specifications, please see table on the next page.



Centring the Bullflex

An engine on flexible mountings will by definition, always move. When the propeller shaft is installed rigidly - which means to say: supported by two or more non-flexible bearings - the propeller shaft should not be affected by engine movements.

If this should happen, damage of engine mounting, coupling and sealing of the shaft may result. Where a rigid shaft assembly is installed, the centring ring can be removed from the Bullflex coupling. This must be done if the distance between the output flange of the gearbox and the first shaft bearing is less than 20 times the shaft diameter. Pendulum movements of the flexibly mounted engine will then not be transmitted onto the propeller shaft, but will be effortlessly absorbed by the Bullflex coupling. Naturally, removal of the centring ring has no adverse effects on the vibration damping properties. Where the propeller shaft is supported by one rigid bearing only, the Bullflex coupling - with its centring ring installed - will function as a flexible ball joint. The propeller shaft will thus be supported and centered inside the Bullflex coupling, regardless of any engine movements.

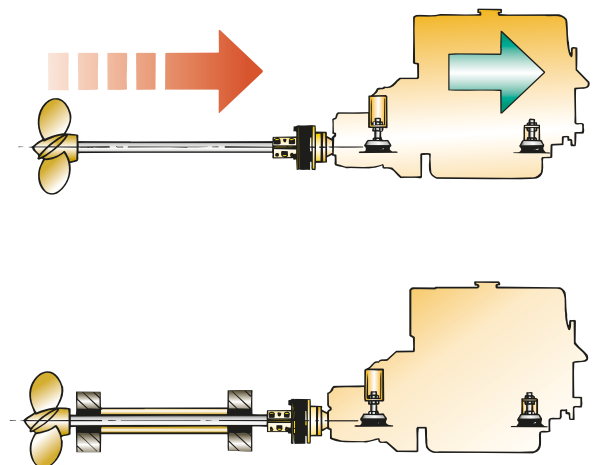

FLEXIBLE COUPLINGS

Type Bullflex

Example

An engine has an output of 84 kW at maximum 3,600 r.p.m. and a gearbox ratio of 2.1:1.

The maximum speed of the propeller shaft is $\frac{3,600}{2,1} = 1,714$ r.p.m.

Therefore, the power to be transmitted per 100 r.p.m. is $\frac{84}{17,14} = 4.9$ kW/100 r.p.m.

From the table, the correct model is a Bullflex 8 for a pleasure craft or a Bullflex 12 for a commercial craft. This formula can also be used with the relevant tables for Uniflex, Combiflex and Type 6 flexible couplings.

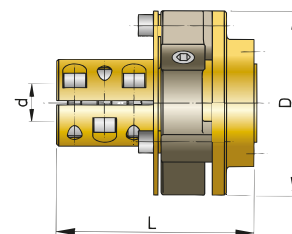

Type Bullflex	DIN 6270 B = pleasure craft kW (HP)/ 100 shaft RPM	DIN 6270 A = commercial craft kW (HP)/ 100 shaft RPM	maximum torque Nm		max. r.p.m. at zero misalignment	max. r.p.m. at 2° misalignment	D inch (mm)	L inch (mm)	d mm
			DIN	DIN					
			6270B	6270A					
1	0.8 (1.1)	0.5 (0.7)	75	45	7000	3500	3 ¹⁵ / ₁₆ (100)	3 ¹¹ / ₃₂ (85)	20, 25
2	1.6 (2.1)	0.9 (1.3)	150	90	6500	3250	4 ²³ / ₃₂ (120)	4 ²³ / ₃₂ (120)	20, 25
4	3.1 (4.3)	2.1 (2.8)	300	200	6000	3000	5 ²⁹ / ₃₂ (150)	6 (152)	25, 30
8	6.3 (8.5)	4.3 (5.8)	600	410	5000	2500	6 ¹¹ / ₁₆ (170)	6 ¹⁷ / ₃₂ (166)	30, 35, 40
12	9.8 (12.8)	7.1 (9.6)	900	540	4000	2000	7 ⁷ / ₈ (200)	6 ³¹ / ₃₂ (177)	35, 40, 45
16	12.6 (17.1)	9.8 (13.3)	1200	935	4000	2000	8 ⁵ / ₆₄ (205)	7 ³ / ₄ (197)	40, 45, 50
32	23.0 (31.3)	18.6 (25.3)	2200	1780	3600	1800	10 ¹⁵ / ₆₄ (260)	10 ²³ / ₆₄ (263)	40, 50, 60, 70

Specifications

Type	DIN 6270 B = pleasure craft kW (HP)/ 100 shaft RPM	DIN 6270 A = commercial craft kW (HP)/ 100 shaft RPM	maximum torque Nm		max. r.p.m. at zero misalignment	max. r.p.m. at 2° misalignment	D inch (mm)	L inch (mm)	d (mm)
			DIN	DIN					
			6270B	6270A					
BULFL0120	0.8 (1.1)	0.5 (0.7)	75	45	7000	3500	3 ¹⁵ / ₁₆ (100)	3 ¹¹ / ₃₂ (85)	20
BULFL0125	0.8 (1.1)	0.5 (0.7)	75	45	7000	3500	3 ¹⁵ / ₁₆ (100)	3 ¹¹ / ₃₂ (85)	25
BULFL0220	1.6 (2.1)	0.9 (1.3)	150	90	6500	3250	4 ²³ / ₃₂ (120)	4 ²³ / ₃₂ (120)	20
BULFL0225	1.6 (2.1)	0.9 (1.3)	150	90	6500	3250	4 ²³ / ₃₂ (120)	4 ²³ / ₃₂ (120)	25
BULFL0425	3.1 (4.3)	2.1 (2.8)	300	200	6000	3000	5 ²⁹ / ₃₂ (150)	6 (152)	25
BULFL0430	3.1 (4.3)	2.1 (2.8)	300	200	6000	3000	5 ²⁹ / ₃₂ (150)	6 (152)	30
BULFL0830	6.3 (8.5)	4.3 (5.8)	600	410	5000	2500	6 ¹¹ / ₁₆ (170)	6 ¹⁷ / ₃₂ (166)	30
BULFL0835	6.3 (8.5)	4.3 (5.8)	600	410	5000	2500	6 ¹¹ / ₁₆ (170)	6 ¹⁷ / ₃₂ (166)	35
BULFL0840	6.3 (8.5)	4.3 (5.8)	600	410	5000	2500	6 ¹¹ / ₁₆ (170)	6 ¹⁷ / ₃₂ (166)	40
BULFL1235	9.8 (12.8)	7.1 (9.6)	900	540	4000	2000	7 ⁷ / ₈ (200)	6 ³¹ / ₃₂ (177)	35
BULFL1240	9.8 (12.8)	7.1 (9.6)	900	540	4000	2000	7 ⁷ / ₈ (200)	6 ³¹ / ₃₂ (177)	40
BULFL1245	9.8 (12.8)	7.1 (9.6)	900	540	4000	2000	7 ⁷ / ₈ (200)	6 ³¹ / ₃₂ (177)	45
BULFL1640	12.6 (17.1)	9.8 (13.3)	1200	935	4000	2000	8 ⁵ / ₆₄ (205)	7 ³ / ₄ (197)	40
BULFL1645	12.6 (17.1)	9.8 (13.3)	1200	935	4000	2000	8 ⁵ / ₆₄ (205)	7 ³ / ₄ (197)	45
BULFL1650	12.6 (17.1)	9.8 (13.3)	1200	935	4000	2000	8 ⁵ / ₆₄ (205)	7 ³ / ₄ (197)	50
BULFL3245	23.0 (31.3)	18.6 (25.3)	2200	1780	3600	1800	10 ¹⁵ / ₆₄ (260)	10 ²³ / ₆₄ (263)	45
BULFL3250	23.0 (31.3)	18.6 (25.3)	2200	1780	3600	1800	10 ¹⁵ / ₆₄ (260)	10 ²³ / ₆₄ (263)	50
BULFL3260	23.0 (31.3)	18.6 (25.3)	2200	1780	3600	1800	10 ¹⁵ / ₆₄ (260)	10 ²³ / ₆₄ (263)	60
BULFL3270	23.0 (31.3)	18.6 (25.3)	2200	1780	3600	1800	10 ¹⁵ / ₆₄ (260)	10 ²³ / ₆₄ (263)	70

Model	Type	Shaft Size Imperial Ø
BUFL011	Type Bullflex1	1"
BUFL021	Type Bullflex2	1"
BUFL041	Type Bullflex4	1"
BUFL0814	Type Bullflex8	1¼"
BUFL0812	Type Bullflex8	1½"
BUFL1212	Type Bullflex12	1½"

Model	Type	Shaft Size Imperial Ø
BUFL1213	Type Bullflex12	1¾"
BUFL1612	Type Bullflex16	1½"
BUFL1613	Type Bullflex16	1¾"
BUFL162	Type Bullflex16	2"
BUFL3213	Type Bullflex32	1¾"
BUFL322	Type Bullflex32	2"

Type	Description
BUL16SET	Set stud & bolts 7/16" UNF for couplings type Bullflex 12 and 16
BUL32SET	Set stud & bolts For couplings type Bullflex 32
TMCSET	Set stud & bolts For couplings type Bullflex with Technodrive Gearbox
UNISET4/5	Set stud & bolts For couplings type 1-8, and for flange 4"/5"

DRIVE FOR PROPELLER SHAFT

Type VETUS DRIVE

More freedom for engine movement, less freedom for vibration

The VETUS DRIVE (Type VDR) is a combination of a self-aligning thrust bearing and a double acting constant velocity joint. The propeller thrust is absorbed by the inbuilt thrust bearing allowing the engine to be set up on softer mountings, resulting in lower vibration and transmitted noise. The VDR is made of stainless, black passivated steel and high performance rubber. This heavy duty VDR has been tested under the toughest conditions and is suitable for maximum thrust up to 24 000 N.

Specifications

- VDR6 is available for shaft diameters of 2" / 2³/₈" / 2³/₄" (50 / 60 / 70 mm)
- VDR2 and 4 are available for shaft diameters of 1" / 1¹/₁₆" / 1³/₈" / 1⁹/₁₆" / 1³/₄" / 2" (25 / 30 / 35 / 40 / 45 / 50 mm)
- Interchangeable with other well-known models
- Durable design with long lifetime

Note

For the most popular Volvo, Yanmar and Kanzaki gearboxes special (also custom made) adapter flanges are available (see page 71).

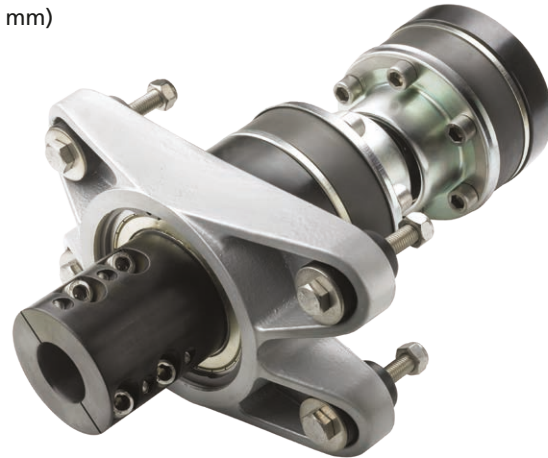

VDR

Dimensions for VDR constant velocity joint

Type	A mm	B mm	C mm	D Ø	E mm	F mm	G mm	H mm	I mm
VDR210254	325	217	101.6	60	63	145	45	25	143
VDR210255	325	217	127	60	63	145	45	25	143
VDR210304	325	217	101.6	60	63	145	45	30	143
VDR210305	325	217	127	60	63	145	45	30	143
VDR215254	376	268	101.6	60	63	145	45	25	175
VDR215255	376	268	127	60	63	145	45	25	175
VDR215304	376	268	101.6	60	63	145	45	30	175
VDR215305	376	268	127	60	63	145	45	30	175
VDR215354	401	268	101.6	69	88	145	45	35	200
VDR215355	401	268	127	69	88	145	45	35	200
VDR221304	429	321	101.6	60	63	145	45	30	183
VDR221305	429	321	127	60	63	145	45	30	183
VDR221354	454	321	101.6	69	88	145	45	35	208
VDR221355	454	321	127	69	88	145	45	35	208
VDR221404	454	321	101.6	69	88	145	45	40	208
VDR221405	454	321	127	69	88	145	45	40	208
VDR421404	437	294	101.6	85	90	214	53	40	188
VDR421405	437	294	127	85	90	214	53	40	188
VDR421454	437	294	101.6	85	90	214	53	45	188
VDR421455	437	294	127	85	90	214	53	45	188
VDR421505	448	294	127	89	102	214	53	50	199
VDR430404	538	395	101.6	85	90	214	53	40	233
VDR430405	538	395	127	85	90	214	53	40	233
VDR430454	538	395	101.6	85	90	214	53	45	233
VDR430455	538	395	127	85	90	214	53	45	233
VDR430504	549	395	101.6	89	101	214	53	50	244
VDR430505	549	395	127	89	101	214	53	50	244
VDR630505	522	333	127	87.5	87.5	250	87	50	250
VDR630605	522	333	127	87.5	87.5	250	87	60	250
VDR630705	522	333	127	87.5	87.5	250	87	70	250
VDR630506	522	333	152.4	87.5	87.5	250	87	50	250
VDR630606	522	333	152.4	87.5	87.5	250	87	60	250
VDR630706	522	333	152.4	87.5	87.5	250	87	70	250
VDR642505	579	362	127	87.5	87.5	250	87	50	250
VDR642605	579	362	127	87.5	87.5	250	87	60	250
VDR642705	579	362	127	87.5	87.5	250	87	70	250
VDR642506	579	362	152.4	87.5	87.5	250	87	50	250
VDR642606	579	362	152.4	87.5	87.5	250	87	60	250
VDR642706	579	362	152.4	87.5	87.5	250	87	70	250

DRIVE FOR PROPELLER SHAFT

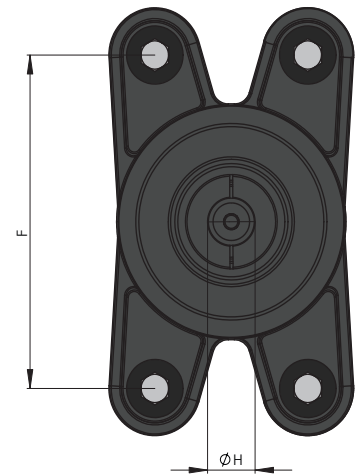
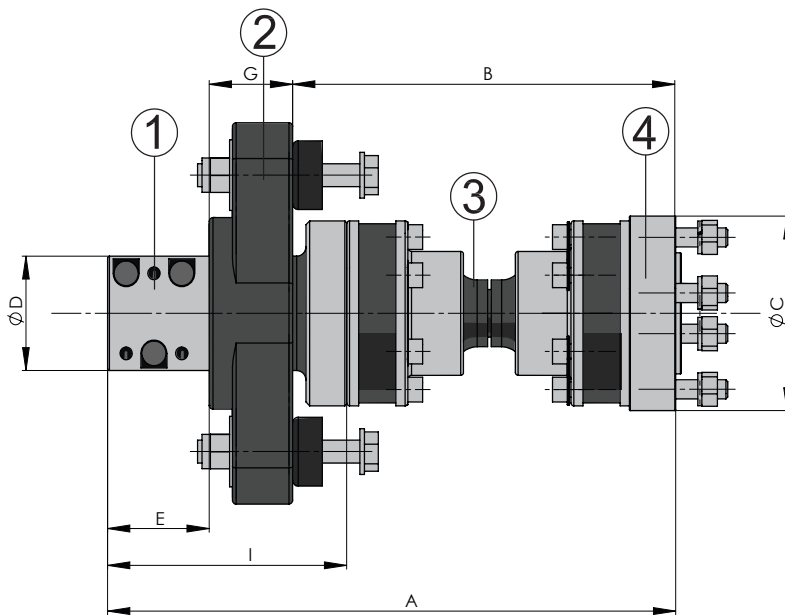

1. Clamp Hub
2. Thrust Bearing
3. CV Joint (Constant Velocity Joint)
4. Flange

The selection of the right VDR constant velocity joint is dependent on some variables: boatspeed, engine HP, RPM, gearbox and shaft diameter. We therefore recommend that you use the VETUS drive selection at our website.

Type FLANGE

Adapter flanges for connecting gearboxes to flexible couplings

These adapter flanges can be used for many gearboxes made by Volvo, Yanmar and Kanzaki and are available as an option. When the pump unit on some hydraulic gearboxes is positioned in a way that it is impossible to install a flexible coupling directly onto the output flange, an intermediate flange will have to be fitted as well. Intermediate flange are available on special request.

Type	Description
FLANGE1	Adapter flange for Yanmar KM2C; KMP2P; KM3P, Kanzaki KC30; KC45 and KC100
FLANGE2	Adapter flange for Volvo MS10A/L; MS15A/L and MS25A/L
FLANGE2A	Adapter flange for Volvo MS; MSB and all types MS2
FLANGE3	Adapter flange for Yanmar KM4A; KM4A1; KMH4A; KBW20-1; KBW21 and Kanzaki KC180



FLANGE



WATER LUBRICATED STERN GEAR

Propeller shaft type SA

Duplex 1-4462 stainless steel propeller shaft

This shaft is machined with 1:10 taper and a keyway as standard. It is supplied with key and propeller nut with integrated zinc anode. The dimensions of taper and keyway are in accordance with ISO 4566.

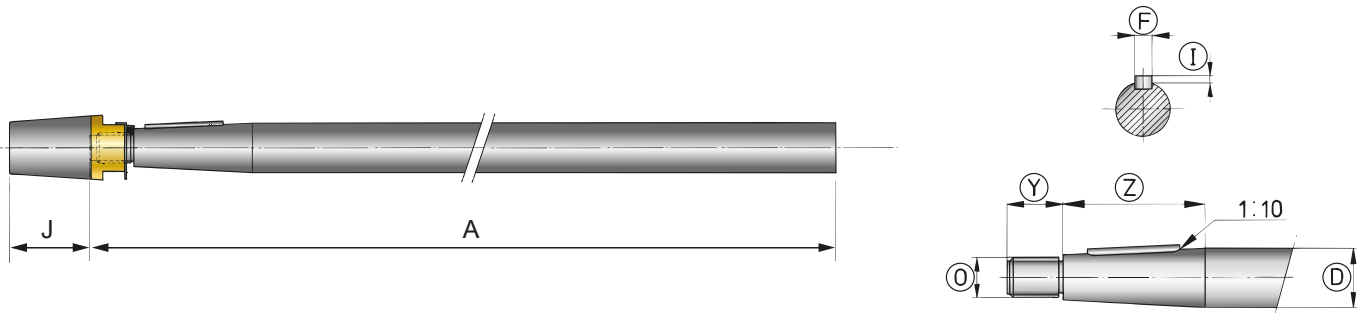

Shaft types with all dimensions in mm

Type	Ø D inch	Shaft lengths (A) (inches / mm)	F	I	J	O	Y	Z
SA25	1 (25)	39 ³ / ₈ / 59 ¹ / ₁₆ / 78 ³ / ₄ / 98 ⁷ / ₁₆ / 118 ¹ / ₈ (1000 / 1500 / 2000 / 2500 / 3000)	⁵ / ₁₆ (8)	¹ / ₈ (3)	¹ / ₁₆ (40)	M16 x 1.5	1 (25)	2 ¹¹ / ₆₄ (55)
SA30	1 ³ / ₁₆ (30)	39 ³ / ₈ / 59 ¹ / ₁₆ / 78 ³ / ₄ / 98 ⁷ / ₁₆ / 118 ¹ / ₈ (1000 / 1500 / 2000 / 2500 / 3000)	⁵ / ₁₆ (8)	¹ / ₈ (3)	2 ¹ / ₄ (57)	M20 x 1.5	1 ³ / ₁₆ (30)	2 ⁶ / ₆₄ (75)
SA35	1 ³ / ₈ (35)	39 ³ / ₈ / 59 ¹ / ₁₆ / 78 ³ / ₄ / 98 ⁷ / ₁₆ / 118 ¹ / ₈ (1000 / 1500 / 2000 / 2500 / 3000)	²⁵ / ₆₄ (10)	¹ / ₈ (3)	2 ¹ / ₈ (54)	M24 x 2	1 ³ / ₈ (35)	1 ¹ / ₃₂ (85)
SA40	1 ⁹ / ₁₉ (40)	on request	¹⁵ / ₃₂ (12)	¹ / ₈ (3)	2 ³³ / ₆₄ (64)	M24 x 2	1 ³ / ₈ (35)	3 ⁴⁷ / ₆₄ (95)
SA45	1 ⁴⁹ / ₆₄ (45)	on request	³⁵ / ₆₄ (14)	⁹ / ₆₄ (3,5)	2 ²³ / ₃₂ (69)	M30 x 2	1 ⁹ / ₁₉ (40)	4 ⁹ / ₆₄ (105)
SA50	1 ³¹ / ₃₂ (50)	on request	³⁵ / ₆₄ (14)	⁹ / ₆₄ (3,5)	3 ⁷ / ₆₄ (79)	M36 x 2	1 ⁴⁹ / ₆₄ (45)	4 ¹⁷ / ₃₂ (115)
SA60	2 ²³ / ₆₄ (60)	on request	⁴⁵ / ₆₄ (18)	⁵ / ₃₂ (4)	3 ²⁵ / ₃₂ (96)	M42 x 3	2 ¹¹ / ₆₄ (55)	5 ¹ / ₈ (130)

Type	Extra charge per 19 ¹¹ / ₁₆ (500)	Type	Extra charge per 19 ¹¹ / ₁₆ (500)
SA25/+	Extra charge per 19 ¹¹ / ₁₆ (500)	SA40/+	Extra charge per 19 ¹¹ / ₁₆ (500)
SA30/+	Extra charge per 19 ¹¹ / ₁₆ (500)	SA45/+	Extra charge per 19 ¹¹ / ₁₆ (500)
SA35/+	Extra charge per 19 ¹¹ / ₁₆ (500)	SA50/+	Extra charge per 19 ¹¹ / ₁₆ (500)
		SA60/+	Extra charge per 19 ¹¹ / ₁₆ (500)

Bronze self-aligning inner bearing and dual shaft seal

The VETUS flexible inner bearing used in this system has dual sealing lips for double security against water leakage.

Type	Description in inches (mm)	H	L	D	d
ZWB25I	Bronze flexible inner bearing Ø 1 (25), with dual lip seal	4 ¹³ / ₃₂ (112)	5 ⁴³ / ₆₄ (144)	1 ¹¹ / ₁₆ (43)	1 (25)
ZWB30I	Bronze flexible inner bearing Ø ³ / ₁₆ (30), with dual lip seal	4 ¹³ / ₃₂ (112)	5 ⁴³ / ₆₄ (144)	1 ⁶¹ / ₆₄ (49,5)	³ / ₁₆ (30)
ZWB35A	Bronze flexible inner bearing Ø 1 ³ / ₈ (35), with dual lip seal	4 ¹³ / ₃₂ (112)	5 ⁴⁵ / ₆₄ (145)	2 ¹³ / ₆₄ (56)	1 ³ / ₈ (35)
ZWB40A	Bronze flexible inner bearing Ø 1 ⁹ / ₁₆ (40), with dual lip seal	4 ³¹ / ₆₄ (114)	5 ²⁹ / ₃₂ (150)	2 ¹³ / ₃₂ (61)	1 ⁹ / ₁₆ (40)
ZWB45A	Bronze flexible inner bearing Ø 1 ⁴⁹ / ₆₄ (45), with dual lip seal	4 ⁵ / ₆₄ (129)	6 ²⁹ / ₆₄ (165)	2 ⁵¹ / ₆₄ (71)	1 ⁴⁹ / ₆₄ (45)
ZWB50A	Bronze flexible inner bearing Ø 1 ³¹ / ₃₂ (50), with dual lip seal	4 ⁵ / ₆₄ (129)	6 ²⁹ / ₆₄ (165)	2 ⁶³ / ₆₄ (76)	1 ³¹ / ₃₂ (50)
ZWB60	Bronze flexible inner bearing Ø 2 ²³ / ₆₄ (60), with dual lip seal	4 ⁵ / ₆₄ (129)	6 ²⁹ / ₆₄ (165)	3 ³⁵ / ₆₄ (90)	2 ²³ / ₆₄ (60)

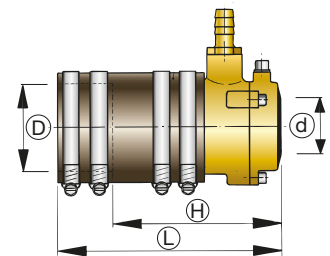

ZWB

ZWB2540 Replacement set for VETUS 1 (25) inner bearing with stuffing box

ZWB3044 Replacement set for VETUS ³/₁₆ (30) inner bearing with stuffing box

All dimensions are in inches (mm)

WATER LUBRICATED STERN GEAR

Self-aligning inner bearing and triple shaft seal for extra security

ZWBH seals are developed for use with water lubricated stern gear. This updated monoblock design works in the same way as the trusted ZWB seals, with the addition of one extra lip seal (three total) for added security. Minimal friction, oil and grease resistant and with a $\frac{3}{8}$ " (10 mm) vulcanised hose pillar for water injection; the ZWBH is ready for another round!

VETUS advises annual lubrication with silicon grease to keep this sterngear seal in optimal condition. ZWBH seals can withstand temperatures between -15° and $+85^{\circ}$ and are suitable for VETUS bronze, steel or GRP stern tubes. The set comes with two stainless steel hose clamps and grease.



ZWBH..

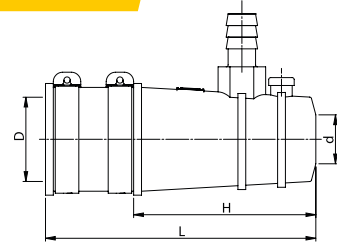

Type	Description	H	L	D	d
ZWBH25	Flexible inner bearing, with triple lip seal	$4\frac{13}{32}$ "	$5\frac{43}{64}$ "	$1\frac{11}{16}$ "	1"
ZWBH30	Flexible inner bearing, with triple lip seal	$4\frac{13}{32}$ "	$5\frac{43}{64}$ "	$1\frac{61}{64}$ "	$1\frac{3}{16}$ "
ZWBH35	Flexible inner bearing, with triple lip seal	$4\frac{13}{32}$ "	$5\frac{45}{64}$ "	$2\frac{13}{64}$ "	$1\frac{3}{8}$ "

Water lubrication connections

There are two possibilities to water lubricate your shaft assembly

1. By means of a water scoop G 3/8, with ball valve, hose pillar, 1 metre of water hose and hose clamps, or
2. By tapping a small amount of water from the main engine's raw water cooling circuit.

Type	Description
WCAPSET	Water scoop kit for $\varnothing 1 - \frac{3}{16} - \frac{3}{8}$ (25-30-35), shaft
WCAPS1/2	Water scoop kit for $\varnothing 1\frac{9}{16} - 1\frac{49}{64} - 1\frac{31}{32}$ (40-45-50), shaft

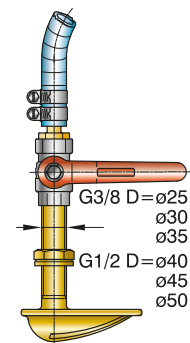

WCAPS

For the second option we offer the ZWBKIT. With this kit you have all you need to water lubricate your shaft assembly by using water from the main engine's raw water cooling circuit.

The kit consists of a T-piece $\frac{45}{64} - \frac{25}{64} - \frac{45}{64}$ (18 -10 -18 mm), 9.84 ft. (3 metres) of $\varnothing \frac{25}{64}$ (10 mm) hose (DWHOSE10A) and 4 hose clamps.

Type	Consist of	Code
ZWBKIT	1 TP1810 T-piece	TP1810
	3 Fresh water hose per metre	DWHOSE10A
	4 Hose clamps AISI 304 $\frac{23}{64}$ (9) $\varnothing \frac{5}{16} - \frac{5}{8}$ (8 - 16)	HCS08



ZWBKIT

Mounting flange for stern tube

The propeller end of the bronze stern tube is provided with an outer cutless bearing and a mounting flange. The slots in the tube are designed for easy replacement of the cutless bearing. A second flange maybe required to secure the inboard end of the stern tube and can be ordered separately.

Type	Ø D inch	R inch	S inch	T inch	U inch	Ø V inch
FLK25	1 (25)	$\frac{45}{64}$ (18)	$3\frac{25}{64}$ (86)	$2\frac{53}{64}$ (72)	$2\frac{3}{4}$ (70)	$\frac{21}{64}$ (8,5)
FLK30	$1\frac{3}{16}$ (30)	$\frac{45}{64}$ (18)	$3\frac{35}{64}$ (90)	$3\frac{5}{64}$ (78)	$2\frac{29}{32}$ (74)	$\frac{21}{64}$ (8,5)
FLK35	$1\frac{3}{8}$ (35)	$\frac{29}{32}$ (23)	$4\frac{13}{32}$ (112)	$3\frac{13}{16}$ (97)	$3\frac{5}{8}$ (92)	$\frac{13}{32}$ (10,5)
FLK40	$1\frac{9}{16}$ (40)	$\frac{29}{32}$ (23)	$4\frac{9}{16}$ (116)	$3\frac{31}{32}$ (101)	$3\frac{25}{32}$ (96)	$\frac{13}{32}$ (10,5)
FLK45	$1\frac{49}{64}$ (45)	$1\frac{7}{64}$ (28)	$5\frac{13}{64}$ (132)	$4\frac{11}{64}$ (118)	$4\frac{1}{4}$ (108)	$\frac{33}{64}$ (13)
FLK50	$1\frac{31}{32}$ (50)	$1\frac{7}{64}$ (28)	$5\frac{7}{16}$ (138)	$4\frac{59}{64}$ (125)	$4\frac{31}{64}$ (114)	$\frac{33}{64}$ (13)
FLK60	$2\frac{23}{64}$ (60)	$1\frac{7}{64}$ (28)	$5\frac{53}{64}$ (148)	$5\frac{23}{64}$ (136)	$4\frac{7}{8}$ (124)	$\frac{33}{64}$ (13)

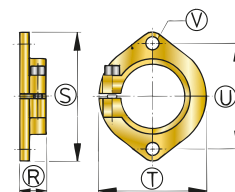

FLK

WATER LUBRICATED STERN GEAR

Bronze stern tube assembly

1. Propeller shaft
2. Stern tube
3. Mounting flange
4. Inner bearing

When ordering, please specify dimensions A, B and D.

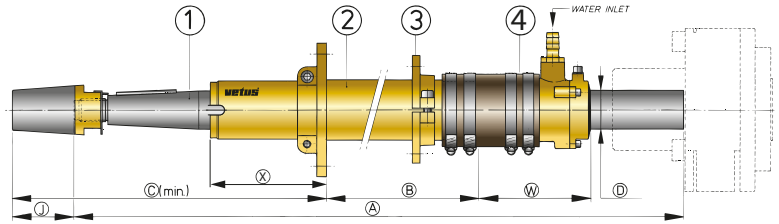

Type	Ø Shaft (D)	A	B	X	C	W	J
BL25	1 (25)	Shaft length	Stern tube length	$3\frac{7}{16}$ (88)	$8\frac{17}{64}$ (210)	$4\frac{13}{32}$ (112)	$1\frac{9}{16}$ (40)
BL30	$1\frac{3}{16}$ (30)			$4\frac{9}{64}$ (105)	$10\frac{33}{64}$ (267)	$4\frac{13}{32}$ (112)	$2\frac{1}{4}$ (57)
BL35	$1\frac{3}{8}$ (35)			$4\frac{39}{64}$ (117)	$11\frac{29}{64}$ (291)	$4\frac{13}{32}$ (112)	$2\frac{1}{8}$ (54)
BL40	$1\frac{9}{16}$ (40)			$4\frac{7}{16}$ (113)	$12\frac{7}{8}$ (327)	$4\frac{31}{64}$ (114)	$2\frac{33}{64}$ (64)
BL45	$1\frac{49}{64}$ (45)			$5\frac{45}{64}$ (145)	$1\frac{49}{64}$ (359)	$5\frac{5}{64}$ (129)	$2\frac{23}{32}$ (69)
BL50	$1\frac{31}{32}$ (50)			$6\frac{3}{8}$ (162)	$15\frac{25}{32}$ (401)	$5\frac{5}{64}$ (129)	$3\frac{7}{64}$ (79)
BL60	$2\frac{23}{64}$ (60)			$7\frac{31}{64}$ (190)	$16\frac{59}{64}$ (430)	$5\frac{5}{64}$ (129)	$3\frac{5}{32}$ (80)

Type BL

Bronze stern tube with mounting flange and 1 cutless bearing aft. The slots in the tube are designed for easy replacement of the cutless bearing.

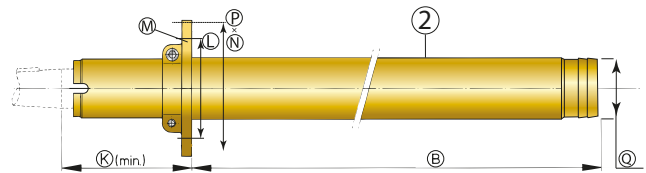

Type	Ø D inch (mm)	Length B	K	L	Ø M	N	P	Q
BL25	1 (25)	$19\frac{11}{16} / 39\frac{3}{8} / 59\frac{1}{16} / 78\frac{3}{4} / 98\frac{7}{16}$ (500 / 1000 / 1500 / 2000)	$3\frac{15}{32}$ (88)	$3\frac{35}{64}$ (90)	$2\frac{1}{64}$ (8,5)	$4\frac{21}{64}$ (110)	$2\frac{23}{64}$ (60)	$1\frac{11}{16}$ (43)
BL30	$1\frac{3}{16}$ (30)	$19\frac{11}{16} / 39\frac{3}{8} / 59\frac{1}{16} / 78\frac{3}{4} / 98\frac{7}{16}$ (500 / 1000 / 1500 / 2000)	$4\frac{6}{64}$ (105)	$3\frac{15}{16}$ (100)	$2\frac{1}{64}$ (8,5)	$4\frac{23}{32}$ (120)	$2\frac{41}{64}$ (67)	$1\frac{61}{64}$ (49,5)
BL35	$1\frac{3}{8}$ (35)	on request	$4\frac{39}{64}$ (117)	$4\frac{21}{64}$ (110)	$1\frac{13}{32}$ (10,5)	$5\frac{13}{64}$ (132)	3 (76)	$2\frac{1}{4}$ (57)
BL40	$1\frac{9}{16}$ (40)	on request	$4\frac{29}{64}$ (113)	$4\frac{9}{16}$ (116)	$1\frac{13}{32}$ (10,5)	$5\frac{7}{16}$ (138)	$3\frac{15}{64}$ (82)	$2\frac{7}{16}$ (62)
BL45	$1\frac{49}{64}$ (45)	on request	$5\frac{45}{64}$ (145)	$5\frac{29}{32}$ (150)	$3\frac{33}{64}$ (13)	$7\frac{3}{32}$ (180)	$3\frac{21}{32}$ (93)	$2\frac{51}{64}$ (71)
BL50	$1\frac{31}{32}$ (50)	on request	$6\frac{3}{8}$ (162)	$6\frac{3}{8}$ (165)	$1\frac{19}{32}$ (15)	$7\frac{3}{4}$ (197)	$3\frac{57}{64}$ (99)	3" 76,1
BL60	$2\frac{23}{64}$ (60)	on request	$7\frac{31}{64}$ (190)	$6\frac{7}{64}$ (155)	$1\frac{19}{32}$ (15)	$7\frac{3}{32}$ (180)	$4\frac{11}{64}$ (106)	$3\frac{5}{8}$ (92)

Type	Description
BL25/+	Extra charge per $19\frac{11}{16}$ (500)
BL30/+	Extra charge per $19\frac{11}{16}$ (500)
BL35/+	Extra charge per $19\frac{11}{16}$ (500)

Type	Description
BL40/+	Extra charge per $19\frac{11}{16}$ (500)
BL45/+	Extra charge per $19\frac{11}{16}$ (500)
BL50/+	Extra charge per $19\frac{11}{16}$ (500)
BL60/+	Extra charge per $19\frac{11}{16}$ (500)

Type BR2

Forward cutless bearing for bronze stern tube. When ordering please specify type BL and type BR2. The tube will be supplied with the second bearing already installed.

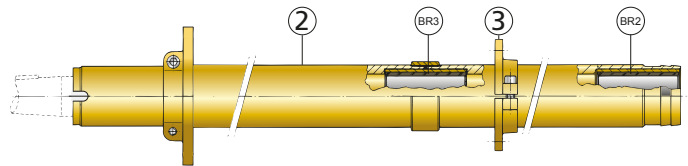

Type BR3

Intermediate cutless bearing for bronze stern tube. When ordering please specify type of BL, type BR2 and type BR3.

The tube will be supplied with ordered bearings already installed.

Forward bearing for stern tubes

Type	Description
BR225	Bearing for Ø 1 (25) stern tube
BR230	Bearing for Ø $1\frac{3}{16}$ (30) stern tube
BR235	Bearing for Ø $1\frac{3}{8}$ (35) stern tube
BR240	Bearing for Ø $1\frac{9}{16}$ (40) stern tube
BR245	Bearing for Ø $1\frac{49}{64}$ (45) stern tube
BR250	Bearing for Ø $1\frac{31}{32}$ (50) stern tube
BR260	Bearing for Ø $2\frac{23}{64}$ (60) stern tube

Intermediate bearing for stern tubes

Type	Description
BR325	Bearing for Ø 1 (25) stern tube
BR330	Bearing for Ø $1\frac{3}{16}$ (30) stern tube
BR335	Bearing for Ø $1\frac{3}{8}$ (35) stern tube
BR340	Bearing for Ø $1\frac{9}{16}$ (40) stern tube
BR345	Bearing for Ø $1\frac{49}{64}$ (45) stern tube
BR350	Bearing for Ø $1\frac{31}{32}$ (50) stern tube
BR360	Bearing for Ø $2\frac{23}{64}$ (60) stern tube

WATER LUBRICATED STERN GEAR

G.R.P. (Polyester) stern tube assembly

Type	Ø D	A	J	Ø Q	W	C	Length B			
BG25/0500	1 (25)	Shaft length	1 ⁹ / ₁₆ (40)	1 ⁴⁷ / ₆₄ (44)	4 ¹³ / ₃₂ (112)	5" (127)	22 ⁷ / ₈ (581,5)	42 ³⁷ / ₆₄ (1081,5)	62 ¹⁷ / ₆₄ (1581,5)	81 ¹⁵ / ₁₆ (2081,5)
BG30/0500	1 ³ / ₁₆ (30)		2 ¹ / ₄ (57)	1 ³¹ / ₃₂ (50)	4 ¹³ / ₃₂ (112)	6 ⁴⁹ / ₆₄ (172)	2 ³⁷ / ₁₆ (595,5)	43 ¹ / ₈ (1095,5)	62 ¹³ / ₁₆ (1595,5)	82 ¹ / ₂ (2095,5)
BG35/0500	1 ³ / ₈ (35)		2 ¹ / ₈ (54)	2 ¹ / ₄ (57)	4 ¹³ / ₃₂ (112)	7 ¹ / ₄ (184)	2 ³⁷ / ₁₆ (595,5)	43 ¹ / ₈ (1095,5)	62 ¹³ / ₁₆ (1595,5)	82 ¹ / ₂ (2095,5)
BG40/0500	1 ⁹ / ₁₆ (40)		2 ³³ / ₆₄ (64)	2 ³⁷ / ₁₆ (62)	4 ³¹ / ₆₄ (114)	8 ²⁷ / ₆₄ (214)	2 ³⁷ / ₁₆ (595,5)	43 ¹ / ₈ (1095,5)	62 ¹³ / ₁₆ (1595,5)	82 ¹ / ₂ (2095,5)

- 1. Propeller shaft
- 2. Stern tube
- 3. Inner bearing

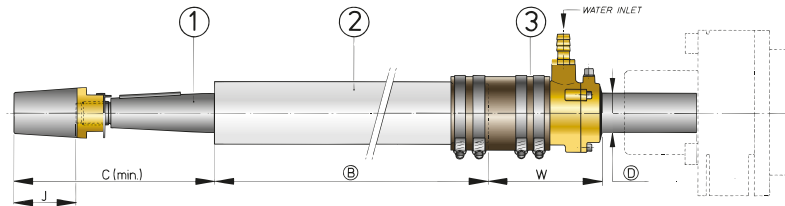

Note

G.R.P. tubes, can be supplied with the same ZWB dual shaft seal as shown on page 72. For the BG25 also the Triple lip seal shown at page 73 can be used. The stern tubes which are provided with a cutless bearing, must be bonded directly into the hull.

G.R.P. stern tubes - type BG

The propeller end of the G.R.P. stern tube is provided with an outer cutless bearing. The stern tubes must be bonded directly into the hull.

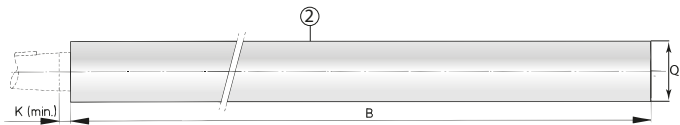

Type	Ø D	Length B			K	Ø Q	
BG25	1 (25)	22 ⁷ / ₈ (581,5)	42 ³⁷ / ₆₄ (1081,5)	62 ¹⁷ / ₆₄ (1581,5)	81 ¹⁵ / ₁₆ (2081,5)	5 ⁵ / ₁₆ (8)	1 ⁴⁷ / ₆₄ (44)
BG30	1 ³ / ₁₆ (30)	2 ³⁷ / ₁₆ (595,5)	43 ¹ / ₈ (1095,5)	62 ¹³ / ₁₆ (1595,5)	82 ¹ / ₂ (2095,5)	2 ²⁵ / ₆₄ (10)	1 ³¹ / ₃₂ (50)
BG35	1 ³ / ₈ (35)	2 ³⁷ / ₁₆ (595,5)	43 ¹ / ₈ (1095,5)	62 ¹³ / ₁₆ (1595,5)	82 ¹ / ₂ (2095,5)	2 ²⁵ / ₆₄ (10)	2 ¹ / ₄ (57)
BG40	1 ⁹ / ₁₆ (40)	on request			1 ¹⁵ / ₃₂ (12)	2 ⁷ / ₁₆ (62)	

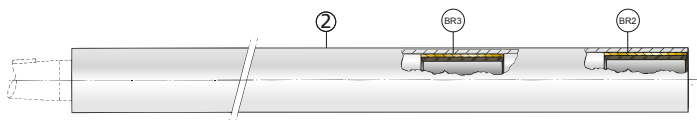

Depending on the length, diameter and RPM of the shaft, there is a need for 1, 2 or 3 cutless bearings.

Forward bearing for stern tubes

Type	Description
BR225	Bearing for Ø 1 (25) stern tube
BR230	Bearing for Ø 1 ³ / ₁₆ (30) stern tube
BR235	Bearing for Ø 1 ³ / ₈ (35) stern tube
BR240	Bearing for Ø 1 ⁹ / ₁₆ (40) stern tube

Intermediate bearing for stern tubes

Type	Description
BR325	Bearing for Ø 1 (25) stern tube
BR330	Bearing for Ø 1 ³ / ₁₆ (30) stern tube
BR335	Bearing for Ø 1 ³ / ₈ (35) stern tube
BR340	Bearing for Ø 1 ⁹ / ₁₆ (40) stern tube

WATER LUBRICATED STERN GEAR

Steel stern tube assembly

When ordering, please specify dimensions A, B and D.

Type	Ø Shaft (D)	Shaft length A	Stern tube length B	C	W	J
BS25	1 (25)	on request	on request	5" (127)	4 ¹³ / ₃₂ (112)	1 ⁹ / ₁₆ (40)
BS30	1 ³ / ₁₆ (30)	on request	on request	6 ⁴⁹ / ₆₄ (172)	4 ¹³ / ₃₂ (112)	2 ¹ / ₄ (57)
BL35S	1 ³ / ₈ (35)	on request	on request	7 ¹ / ₄ (184)	4 ¹³ / ₃₂ (112)	2 ¹ / ₈ (54)
BL40S	1 ⁹ / ₁₆ (40)	on request	on request	8 ⁷ / ₆₄ (206)	4 ³¹ / ₆₄ (114)	2 ³³ / ₆₄ (64)
BL45S	1 ⁴⁹ / ₆₄ (45)	on request	on request	8 ⁵⁷ / ₆₄ (226)	5 ⁵ / ₆₄ (129)	2 ²³ / ₃₂ (69)
BL50S	1 ³¹ / ₃₂ (50)	on request	on request	10" (254)	5 ⁵ / ₆₄ (129)	3 ⁷ / ₆₄ (79)
BL60S	2 ²³ / ₆₄ (60)	on request	on request	11 ¹⁹ / ₆₄ (287)	3 ²¹ / ₃₂ (93)	3 ²⁵ / ₃₂ (96)

1. Propeller shaft
2. Stern tube
3. Inner bearing

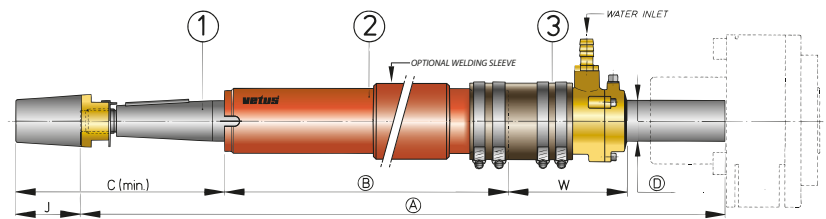

Steel stern tubes

The propeller end of the steel stern tube is provided with an outer cutless bearing. The slots in the tube are designed for easy replacement of the cutless bearing. All steel stern tubes may be supplied with additional sleeves to reduce distortion when welding. Please specify when ordering.

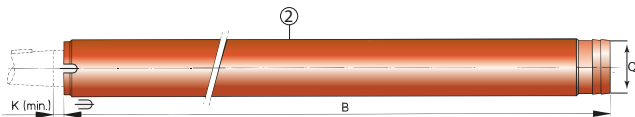

Type	Ø D	Length B	K	Ø Q
BS25	1 (25)	on request	5 ⁵ / ₁₆ (8)	1 ⁴⁷ / ₆₄ (44)
BS30	1 ³ / ₁₆ (30)	on request	2 ⁵ / ₆₄ (10)	2 ¹ / ₆₄ (51)
BL35S	1 ³ / ₈ (35)	on request	2 ⁵ / ₆₄ (10)	2 ¹ / ₄ (57)
BL40S	1 ⁹ / ₁₆ (40)	on request	1 ⁵ / ₃₂ (12)	2 ⁷ / ₁₆ (62)
BL45S	1 ⁴⁹ / ₆₄ (45)	on request	1 ⁵ / ₃₂ (12)	2 ³ / ₄ (70)
BL50S	1 ³¹ / ₃₂ (50)	on request	1 ⁹ / ₃₂ (15)	3" (76,1)
BL60S	2 ²³ / ₆₄ (60)	on request	1 ⁹ / ₃₂ (15)	3 ⁵ / ₈ (92)

Type BR2

Forward cutless bearing for steel stern tube. When ordering please specify type BL and type BR2. The tube will be supplied with second bearing already installed.

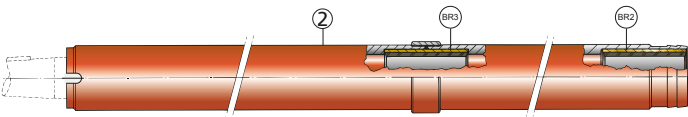

Forward bearing for stern tubes

Type	Description
BR225	Bearing for Ø 1 (25) stern tube
BR230	Bearing for Ø 1 ³ / ₁₆ (30) stern tube
BR235	Bearing for Ø 1 ³ / ₈ (35) stern tube
BR240	Bearing for Ø 1 ⁹ / ₁₆ (40) stern tube
BR245	Bearing for Ø 1 ⁴⁹ / ₆₄ (45) stern tube
BR250	Bearing for Ø 1 ³¹ / ₃₂ (50) stern tube
BR260	Bearing for Ø 2 ²³ / ₆₄ (60) stern tube

Type BR3

Intermediate cutless bearing for steel stern tube. When ordering please specify type BL, type BR2 and type BR3.

The tube will supplied with ordered bearings already installed.

Intermediate bearing for stern tubes

Type	Description
BR325S	Bearing for Ø 1 (25) stern tube
BR330S	Bearing for Ø 1 ³ / ₁₆ (30) stern tube
BR335S	Bearing for Ø 1 ³ / ₈ (35) stern tube
BR340S	Bearing for Ø 1 ⁹ / ₁₆ (40) stern tube
BR345S	Bearing for Ø 1 ⁴⁹ / ₆₄ (45) stern tube
BR350S	Bearing for Ø 1 ³¹ / ₃₂ (50) stern tube
BR360S	Bearing for Ø 2 ²³ / ₆₄ (60) stern tube

WATER LUBRICATED STERN GEAR

Type CS with dual lip seal and rubber bushings

This water-lubricated propeller shaft assembly uses a thick walled steel outer tube which can be welded into a steel boat with minimum distortion. In this steel tube you can easily fit a bronze stern tube with the aid of rubber bushings.

Specifications

- 1 rear cutless bearing (additional bearings can be supplied on request)
- Bronze stern tube (can be supplied with a VETUS self-aligning inner bearing with dual lip seal type ZWB)

For dimensions see table below. Please state dimensions A, B, D and E when ordering.

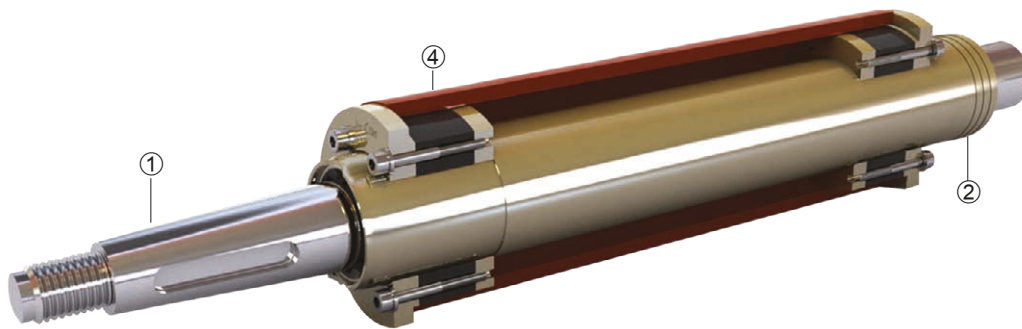

1. Propeller shaft
2. Stern tube
3. Inner bearing
4. Thick walled steel outer tube

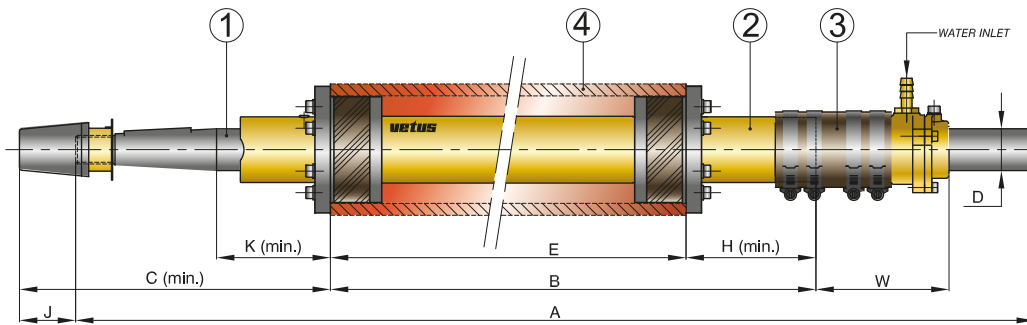

Ø D	A	B	C	E	H	J	K	W	Precision steel tube
1 ³ / ₈ (35)	on request	on request	11 ²⁹ / ₆₄ (291)	on request	2 ²³ / ₆₄ (60)	2 ¹ / ₈ (54)	4 ³⁹ / ₆₄ (117)	4 ¹³ / ₃₂ (112)	I.D. = 89 / O.D. = 101.6
1 ⁹ / ₁₆ (40)	on request	on request	12 ⁷ / ₈ (327)	on request	2 ³¹ / ₆₄ (63)	2 ³³ / ₆₄ (64)	4 ²⁹ / ₆₄ (133)	4 ³¹ / ₆₄ (114)	I.D. = 89 / O.D. = 101.6
1 ⁴⁹ / ₆₄ (45)	on request	on request	14 ⁹ / ₆₄ (359)	on request	2 ³¹ / ₆₄ (63)	2 ²³ / ₃₂ (69)	5 ⁴⁵ / ₆₄ (145)	5 ⁵ / ₆₄ (129)	I.D. = 112.8 / O.D. = 127
1 ³¹ / ₃₂ (50)	on request	on request	15 ²⁵ / ₃₂ (401)	on request	2 ³¹ / ₆₄ (63)	3 ⁷ / ₆₄ (79)	6 ³ / ₈ (162)	5 ⁵ / ₆₄ (129)	I.D. = 112.8 / O.D. = 127



PROPELLERS

The most essential component of your boat

VETUS makes good use of an especially developed computer programme, which determines exactly the right propeller for your boat. The most important elements of propeller design and manufacture are balance, dimensions, material and the blade area.

1. If you bear in mind that a propeller is often rotating at 2.000 r.p.m. (more than 30 revolutions per second), you will understand that it is an absolute must that a good propeller is well-balanced.
2. In order to achieve the best performance and to minimize vibration, it is extremely important to ensure that the pitch of each blade is identical and that the distance between the blades does not vary. This requires great manufacturing precision.
3. VETUS propellers are made of manganese bronze, an extremely resilient, yet flexible material.
4. The choice of a good propeller with all above combined qualities, is of the utmost importance.
5. A propeller specialist must always determine the diameter and pitch and the required (fixed) Fa/F ratio. This means the total area of the propeller circle (F) in comparison to the surface area (stretched and developed) of all blades (Fa). The choice of the Fa/F ratio is dependent on the shape of the underwater section and the speed of the boat in question.

3-Bladed propeller
Type P3B

P3B

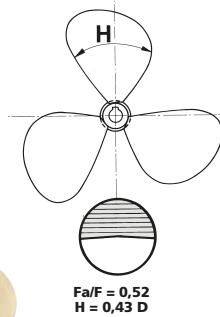

3-Bladed propeller
Type P3C

P3C

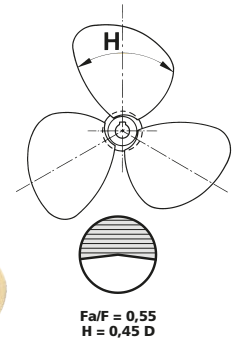
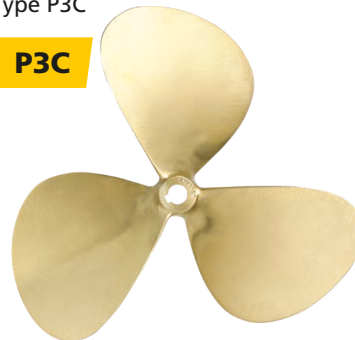

4-Bladed propeller
Type P4E

P4E

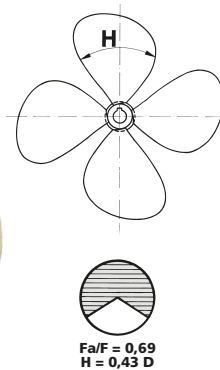

4-Bladed propeller
Type P4G

P4G

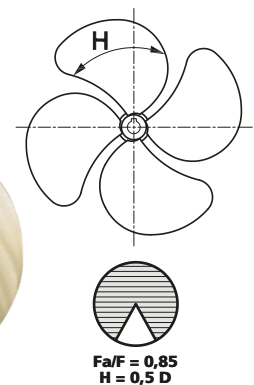

PROPELLERS

Propellers of different types and dimensions are available to special order

5-Bladed propeller
Type P5G

P5G

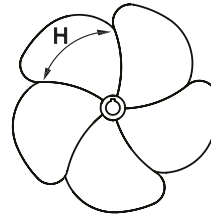

$$\begin{aligned} Fa/F &= 1,06 \\ H &= 0,5 D \end{aligned}$$

Note

Types P3B, P3C and P4E have standard shaft holes and keyway. Dimensions are according to ISO 4566. Sizes are indicated in the tables. VETUS can also supply matching propeller shafts from stock (see page 72).

Standard taper of shaft holes of VETUS propellers (1:10). Dimensions according to ISO 4566

Propeller diameter					Shaft hole		Hub	
3-bladed propeller P3B	3-bladed propeller P3C	4-bladed propeller P4E	4-bladed propeller P4G	5-bladed propeller P5G	Largest diameter D inch (mm)	Smallest diameter d inch (mm)	Hub length L inch (mm)	Keyway width B inch (mm)
12"-15"	12"-15"	14"-15"	-	-	1 (25)	$\frac{3}{4}$ (19)	$2\frac{23}{64}$ (60)	$\frac{5}{16}$ (8)
16"-18"	16"-18"	16"-17"	on request	on request	$1\frac{3}{16}$ (30)	$\frac{55}{64}$ (22)	$3\frac{5}{32}$ (80)	$\frac{5}{16}$ (8)
19"-21"	19"-21"	18"-20"	on request	on request	$1\frac{3}{8}$ (35)	$1\frac{1}{32}$ (26)	$3\frac{35}{64}$ (90)	$\frac{25}{64}$ (10)
22"-24"	22"-24"	21"-22"	on request	on request	$1\frac{9}{16}$ (40)	$1\frac{3}{16}$ (30)	$3\frac{15}{16}$ (100)	$\frac{15}{32}$ (12)
25"	25"	23"-24"	on request	on request	$1\frac{49}{64}$ (45)	$1\frac{11}{32}$ (34)	$4\frac{21}{64}$ (110)	$\frac{35}{64}$ (14)
greater than 25"	greater than 25"	on request	on request	on request	$1\frac{31}{32}$ (50)	$1\frac{1}{2}$ (38)	$4\frac{23}{32}$ (120)	$\frac{35}{64}$ (14)

How to order?

Please give us the propeller diameter and pitch, as well as the number of blades, the sense of rotation and the dimensions of the hub and the taper as shown below. In case propeller details are not known to you: VETUS makes use of an especially developed programme, which determines the exact right propeller for your boat.

Propeller shaft taper

All stock VETUS propellers have a standard taper of 1:10. This means that the difference between the largest and the smallest diameter of the tapered hole represents 10% of the propeller hub length ($D-d=0.1 \times L$). If required, we can machine the hub to a taper of 1:12, 1:16, etc. It takes a few days extra delivery time plus a small surcharge (see pricelist).

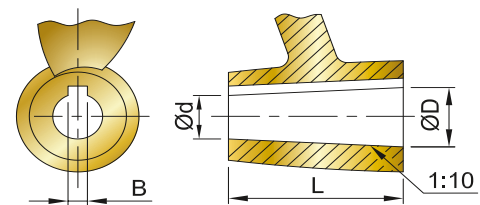

Note

VETUS offers a wide variety of propeller sizes to special order. Propellers are supplied in manganese bronze. Aluminium bronze propellers can also be supplied to special order.

Zinc anode for shaft nut

Type	Specifications
SN25B	Spare zinc anode for \varnothing 1 (25 mm) shaft nut
SN30B	Spare zinc anode for \varnothing $1\frac{3}{16}$ (30 mm) shaft nut
SN35B	Spare zinc anode for \varnothing $1\frac{3}{8}$ (35 mm) shaft nut
SN40B	Spare zinc anode for \varnothing $1\frac{9}{16}$ (40 mm) shaft nut
SN45B	Spare zinc anode for \varnothing $1\frac{49}{64}$ (45 mm) shaft nut
SN50B	Spare zinc anode for \varnothing $1\frac{31}{32}$ (50 mm) shaft nut
SN60B	Spare zinc anode for \varnothing $2\frac{23}{64}$ (60 mm) shaft nut

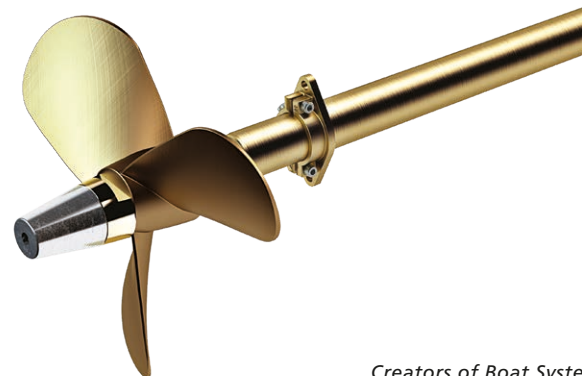

For more information or a overview of anodes see page 398.

BEARINGS

Water lubricated cutless bearings

These cutless bearings have a polyurethane-rubber lining. The outer bushings are made of either brass or phenolic resin. Phenolic resin is lightweight, cannot corrode and can easily be replaced. These bearings are available for shaft diameters between $\text{Ø } 25/32$ and $3^{15}/16$ " (20 and 100 mm) and from $\text{Ø } 1$ " through $\text{Ø } 4$ ". VETUS rubber bearings are also available for larger shaft diameters to special order.

For dimensions please see tables below.

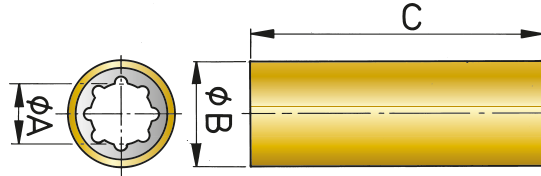

Rubber bearings with shaft size (A) in mm and shell size (B) in inches. Length (C) in mm.

Brass shell	Phenolic shell	A	B**	C
RULAGER20	RULAG25PH	20 *	1 $\frac{1}{4}$	76
RULAGER22		22 *	1 $\frac{1}{4}$	76
RULAGER25		25	1 $\frac{1}{2}$	100
RULAGER30	RULAG30PH	30	1 $\frac{3}{4}$	127
RULAGER35	RULAG35PH	35	1 $\frac{7}{8}$	140
RULAGER40	RULAG40PH	40	2 $\frac{1}{8}$	160
RULAGER45	RULAG45PH	45	2 $\frac{3}{8}$	180
RULAGER50	RULAG50PH	50	2 $\frac{5}{8}$	200
RULAGER60	RULAG60PH	60	3	240
RULAGER65		65 *	3 $\frac{3}{8}$	260
RULAGER70	RULAG70PH	70	3 $\frac{1}{2}$	280
RULAGER80	RULAG80PH	80	4	320

Rubber bearings with shaft size (A) in mm and shell size (B) in mm. Length (C) in mm.

Brass shell	Phenolic shell	A	B	C
RL2540	RL2540PH	25	40	100
RL3045	RL3045PH	30	45	120
RL3550	RL3550PH	35	50	140
RL4055	RL4055PH	40	55	160
RL4565	RL4565PH	45	65	180
RL5070	RL5070PH	50	70	200
RL6080	RL6080PH	60	80	240
RL7090	RL7090PH	70	90	280
RL8010	RL8010PH	80	100	320
RL9011	RL9011PH	90	110	360
RL1012	RL1012PH	100	125	400

Rubber bearings with shaft size (A) in inches and shell size (B) in inches. Length (C) in inches.

Brass shell	Phenolic shell	A	B	C
RULAG1	RL1PH	1	1 $\frac{1}{2}$	4
RULAG11/8	RL11/8PH	1 $\frac{1}{8}$	1 $\frac{5}{8}$	4 $\frac{1}{2}$
RULAG11/4	RL11/4PH	1 $\frac{1}{4}$	1 $\frac{3}{4}$	5
RULAG13/8	RL13/8PH	1 $\frac{3}{8}$	1 $\frac{7}{8}$	5 $\frac{1}{2}$
RULAG11/2	RL11/2PH	1 $\frac{1}{2}$	2	6
RULAG15/8		1 $\frac{5}{8}$	2 $\frac{1}{8}$	6 $\frac{1}{2}$
RULAG13/4	RL13/4PH	1 $\frac{3}{4}$	2 $\frac{3}{8}$	7
RULAG2	RL2PH	2	2 $\frac{5}{8}$	8
RULAG21/4	RL21/4PH	2 $\frac{1}{4}$	3	9
RULAG21/2	RL21/2PH	2 $\frac{1}{2}$	3 $\frac{1}{4}$	10
RULAG23/4	RL23/4PH	2 $\frac{3}{4}$	3 $\frac{3}{4}$	11
RULAG3	RL3PH	3	4	12
RULAG31/2	RL31/2PH	3 $\frac{1}{4}$	4 $\frac{1}{2}$	14
RULAG4	RL4PH	4	5	16



* Available to special order
 ** Used in VETUS stern gear



EXHAUST SYSTEMS

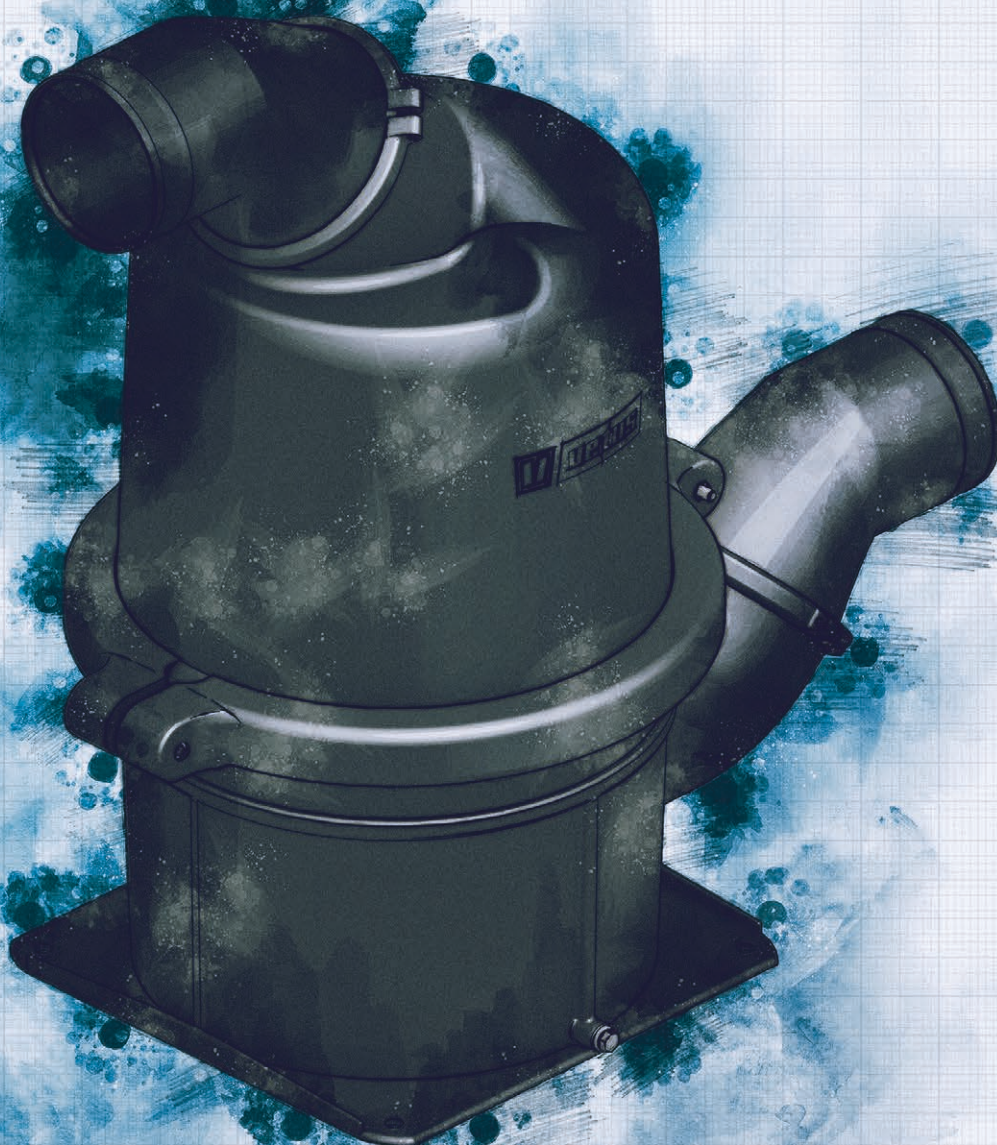

Overview VETUS exhaust systems

Waterlock

Standard installations see page 86

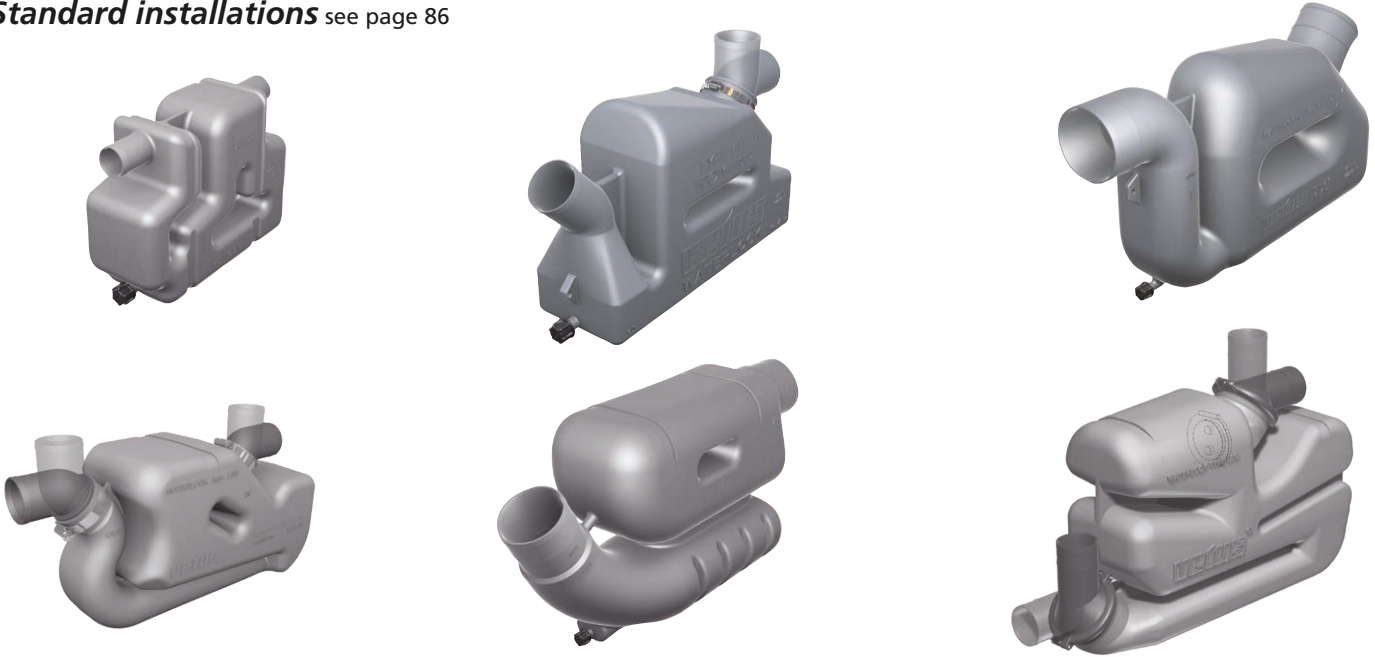

Waterlock

Dual stage see page 88



Waterlock

For installation in low building space, for instance sailing boats see page 89

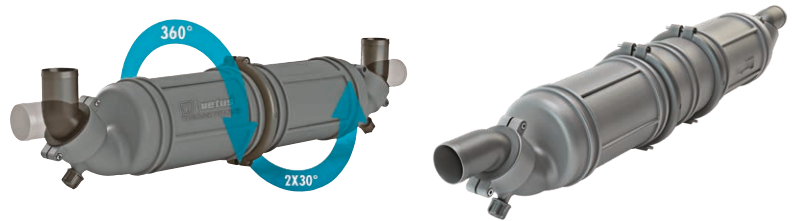

Waterlock

For larger boats and commercial applications see page 90



Muffler

For all types see page 94



Gooseneck see page 95

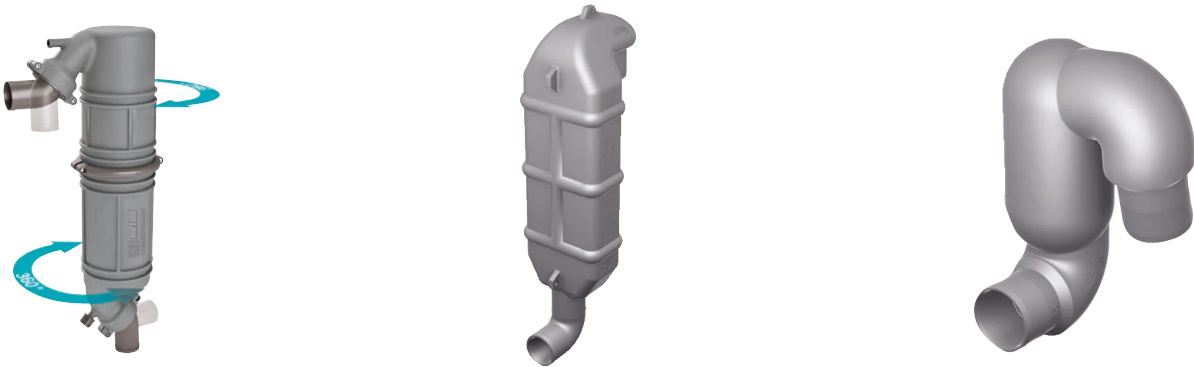

Airvent see page 96



Separator see page 98



Transom exhaust connections see page 99



A WET EXHAUST SYSTEM

A 'dry' exhaust system causes a tremendous amount of noise and diesel exhaust smell. A diesel engine can easily produce an exhaust gas temperature of 1112°F (600°C) or more. However, reduction of exhaust gas temperature to about 104 or 122°F (40 or 50°C) can be achieved by injecting the engine cooling water into the exhaust line. This is how a "wet" exhaust system works. In addition, the typical diesel exhaust smell is also considerably reduced.

Depending on the overall system design, the exhaust gas may flow through one or more of:

- Exhaust hose
- A waterlock/muffler
- A gooseneck
- A transom connector

Why VETUS exhaust systems

All VETUS exhaust systems meet the high standards our customers expect, with just some of the benefits highlighted below:

- All VETUS exhaust systems meet required ABYC standards
- Many system components come complete with rotating connections and bodies for easy installation of hoses from any angle
- Excellent noise reduction is combined with minimal back pressure
- Some available systems use a combination of gooseneck/muffler and waterlock/muffler
- The ASD airvent can be easily dismantled by hand for cleaning and all materials are fully corrosion resistant
- Exhaust hoses are extremely flexible, making installation quick and easy

VETUS OFFERS THE FOLLOWING EXHAUST COMPONENTS

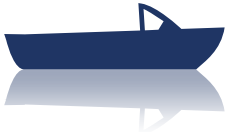

Waterlocks type WLOCK
 Waterlocks type LS
 Dual stage waterlocks type NLP
 Waterlock type MG
 Gooseneck type WLOCKLT and LT
 Waterlock/muffler type NLPH / NLPG



Up to 121hp with 0,1 bar back pressure
 Waterlock type NLPHD

Up to 302hp with 0,1 bar back pressure
 Waterlock type HPW (High Performance Waterlock)



Waterlock/muffler type NLPH
 Mufflers type DEMP
 Mufflers type MV and MF

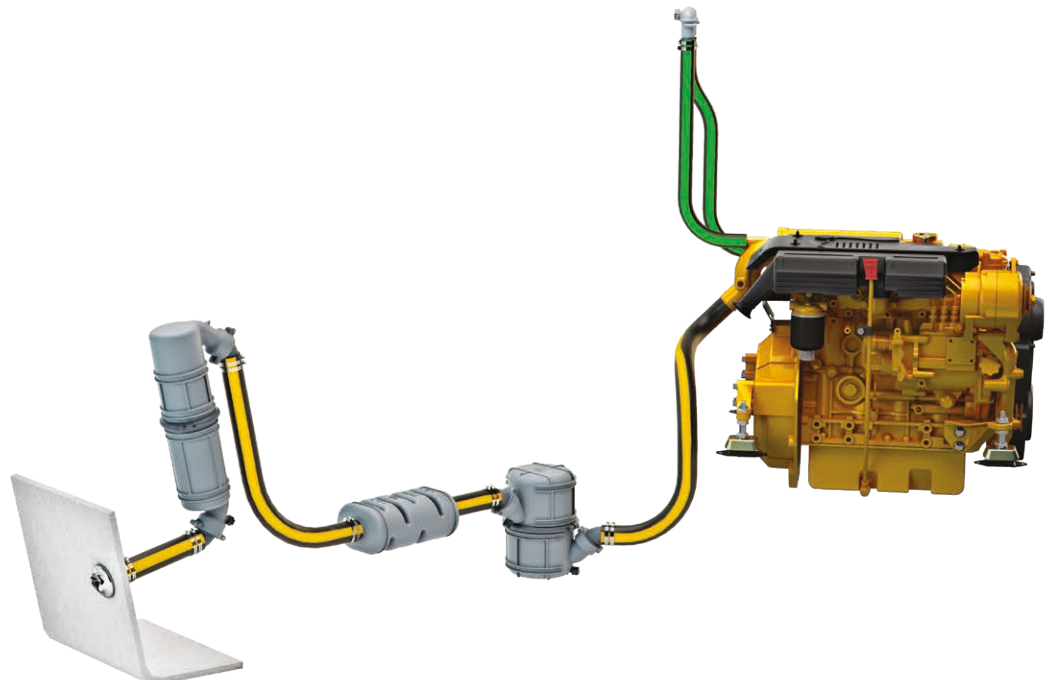

PREVENTING WATER RUNNING BACK TO THE ENGINE

Installation above or below waterline

The cooling water injection point is crucial. If the water injection point is 6" (15 cm) or more above the waterline, the cooling water can be injected directly into the exhaust system. But when it is less than 6" (15 cm) above or even below the waterline, the cooling system can siphon water through the intake when the engine is turned off. Water can fill up the exhaust system and get back into the engine through the exhaust valves. This can be prevented by using a breather hose (1) in the cooling water system or an air vent (2).

Calculation tool

The waterlock capacity can be easily determined by the following formula:

$$2 \times \left(\frac{\pi}{4} \times D^2 \times L \right) \times 0,25 / 1000.000$$

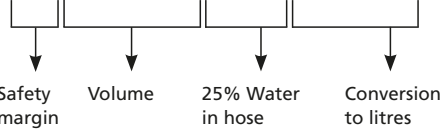

D = Internal diameter of the hose (mm)

L = Length of hose (mm)

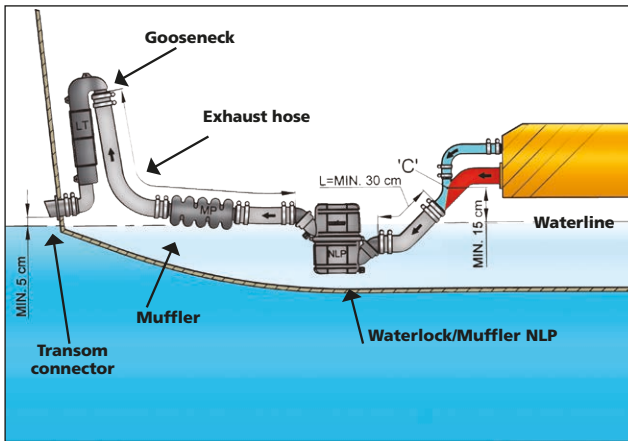

Exhaust system with the water injection point "C" **6" (15 cm) or more** above the waterline.

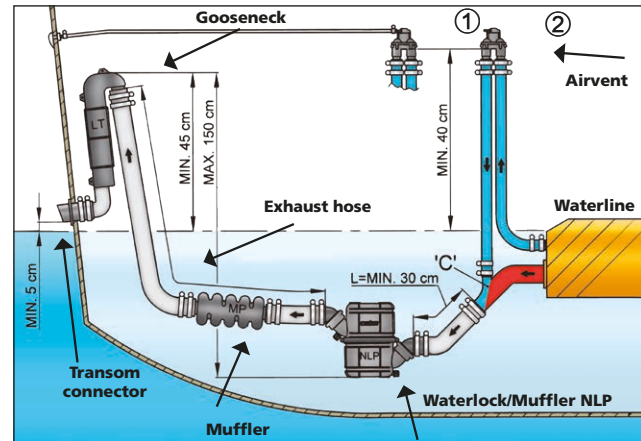

Exhaust system with the water injection point "C" **below or less than 6" (15 cm)** above the waterline.

How to choose your perfect exhaust system

The combination of engine and waterlock determines the optimum sound attenuation. By using this table you can choose a waterlock which is suitable for your engine power and exhaust diameter.

Inlet inches	Inlet (mm)	Exhaust inches	Exhaust (mm)	Type LP, MF, NLP, LSS, LSL, NLPD	Type MV	Type MGP, MGS, MGL, LSG, HPW
1 3/16"	30	1 3/16"	30	13,6 hp / 10 kW	-	-
1 9/16"	40	1 9/16"	40	24,5 hp / 18 kW	-	-
1 3/4"	45	1 3/4"	45	30 hp / 22 kW	-	-
2 1/64"	51	2 1/64"	51	38 hp / 28 kW	-	-
2 3/8"	60	2 3/8"	60	53 hp / 39 kW	-	46 hp / 34 kW
3"	76	3"	76	86 hp / 63 kW	-	75 hp / 55 kW
3 1/2"	90	3 1/2"	90	121 hp / 89 kW	141 hp / 103 kW	105 hp / 77 kW
4"	102	4"	102	155 hp / 114 kW	181 hp / 133 kW	136 hp / 100 kW
4"	102	5"	127	-	-	173 hp / 127 kW
5"	127	5"	127	241 hp / 177 kW	281 hp / 206 kW	211 hp / 155 kW
5"	127	6"	152	-	-	256 hp / 188 kW
6"	152	6"	152	345 hp / 254 kW	403 hp / 296 kW	302 hp / 222 kW
6"	152	8"	203	-	-	420 hp / 308 kW
8"	203	8"	203	-	-	539 hp / 396 kW
8"	203	10"	254	-	-	691 hp / 508 kW
10"	254	10"	254	-	-	844 hp / 620 kW

Note

Values calculated at a back pressure of 0.1 bar. When a higher back pressure is allowed by the engine manufacturer, VETUS waterlocks can be used for engines with a higher output than indicated in this table.

WATERLOCKS

Easy installation

Once the engine of your boat has stopped a VETUS waterlock of the correctly chosen capacity will make sure that water will not run back into the engine. All VETUS waterlocks are provided with a drain plug for winter storage.

Type WLOCKLP

- Suitable for exhaust hose with an internal diameter of $\text{Ø } 1\frac{3}{16}$ " (30 mm)



WLOCKLP30

Type	Capacity (gal.)	A inches (mm)	B inches (mm)	Ø (D) inches (mm)
WLOCKLP30	0.6	$9\frac{29}{64} \times 3\frac{9}{16}$ (240 x 90)	$7\frac{1}{16}$ (180)	$1\frac{3}{16}$ (30)

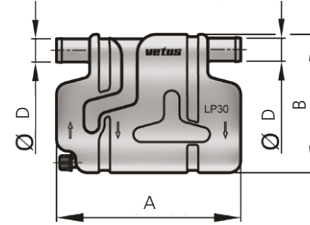

Type WLOCKLR

- Suitable for exhaust hose with internal diameter of $\text{Ø } 1\frac{9}{16}$ " (40 mm), $1\frac{3}{4}$ " (45 mm) or 2" (50 mm)



WLOCKLR

Type	Capacity (gal.)	A inches (mm)	B inches (mm)	Ø (D) inches (mm)
WLOCKL40R	1.05	$14\frac{5}{8} \times 4\frac{5}{16}$ (372 x 110)	$8\frac{5}{16}$ (211)	$1\frac{9}{16}$ (40)
WLOCKL45R	1.05	$14\frac{5}{8} \times 4\frac{5}{16}$ (372 x 110)	$8\frac{5}{16}$ (211)	$1\frac{3}{4}$ (45)
WLOCKL50R	1.05	$14\frac{5}{8} \times 4\frac{5}{16}$ (372 x 110)	$8\frac{5}{16}$ (211)	$1\frac{15}{16}$ (50)

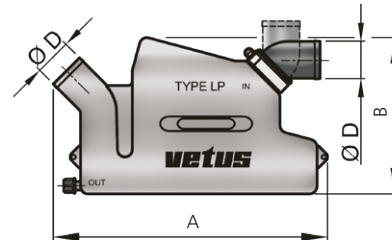

Type WLOCKLS and WLOCKLP

- Suitable for exhaust hose with internal diameter of $\text{Ø } 2$ " (50 mm), $2\frac{3}{8}$ " (60 mm), 3" (75 mm) or $3\frac{1}{2}$ " (90 mm)



WLOCKL50S

WLOCKLP

Type	Capacity (gal.)	A inches (mm)	B inches (mm)	Ø (D) inches (mm)
WLOCKL50S	2.77	$20\frac{7}{8} \times 5\frac{7}{16}$ (530 x 138)	$11\frac{7}{16}$ (290)	2 (50)
WLOCKLP60	2.77	$20\frac{7}{8} \times 5\frac{7}{16}$ (530 x 138)	$11\frac{7}{16}$ (290)	$2\frac{3}{8}$ (60)
WLOCKLP75	2.77	$20\frac{7}{8} \times 5\frac{7}{16}$ (530 x 138)	$11\frac{7}{16}$ (290)	3 (75)
WLOCKLP90	2.77	$20\frac{7}{8} \times 5\frac{7}{16}$ (530 x 138)	$11\frac{7}{16}$ (290)	$3\frac{1}{2}$ (90)

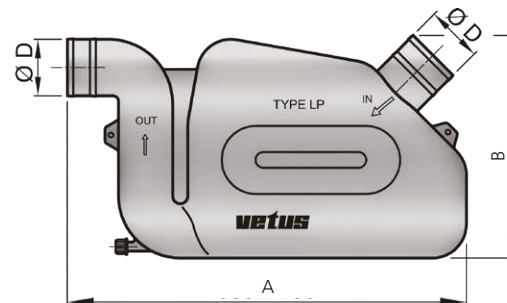

WATERLOCKS

Long exhaust systems

Sometimes the exhaust line is so long that an extra large capacity waterlock is required to prevent water from running back into the engine. The VETUS waterlock type LS is the ideal solution.

Type LSSA

For standard hose connections

- Suitable for exhaust hose with internal diameter of $\varnothing 1\frac{3}{16}$ " (40 mm), $1\frac{3}{4}$ " (45 mm) or 2" (50 mm)
- 360° Rotating inlet and outlet stubs
- Comes with 1 securing strap

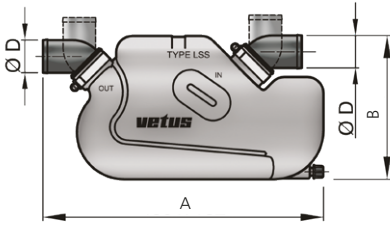

Type	Capacity (gal.)	A inches (mm)	B inches (mm)	Ø (D) inches (mm)
LSS40A	1.25	16 ¹⁵ / ₁₆ x 6 (430 x 152)	8 ⁷ / ₈ (225)	1 ⁹ / ₁₆ (40)
LSS45A	1.25	16 ¹⁵ / ₁₆ x 6 (430 x 152)	8 ⁷ / ₈ (225)	1 ³ / ₄ (45)
LSS50A	1.25	16 ¹⁵ / ₁₆ x 6 (430 x 152)	8 ⁷ / ₈ (225)	2 (50)

LSSA



Type LSL

For long relatively straight exhaust runs

- Suitable for exhaust hose with internal diameter of $\varnothing 2\frac{3}{8}$ " (60 mm), 3" (75 mm) or $3\frac{1}{2}$ " (90 mm)
- Non-rotating inlet and outlet connections
- Comes with 2 securing straps

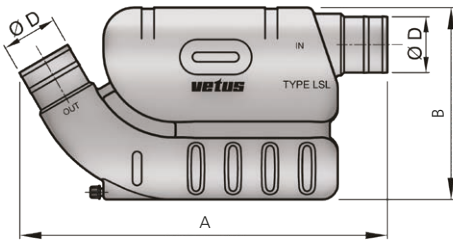

Type	Capacity (gal.)	A inches (mm)	B inches (mm)	Ø (D) inches (mm)
LSL60	4.23	23 ⁷ / ₁₆ x 6 ¹¹ / ₁₆ (596 x 170)	12 ³ / ₁₆ (310)	2 ³ / ₈ (60)
LSL75	4.23	23 ⁷ / ₁₆ x 6 ¹¹ / ₁₆ (596 x 170)	12 ³ / ₁₆ (310)	3 (75)
LSL90	4.23	23 ⁷ / ₁₆ x 6 ¹¹ / ₁₆ (596 x 170)	12 ³ / ₁₆ (310)	3 ¹ / ₂ (90)

LSL



Type LSG

With incorporated check valve for extra security

- Suitable for exhaust hose with internal diameter of $\varnothing 2\frac{3}{8}$ " (60 mm), 3" (75 mm) or $3\frac{1}{2}$ " (90 mm)
- 360° Rotating inlet and outlet stubs
- Comes with 2 securing straps

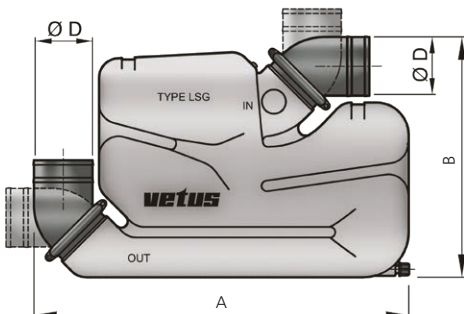

Type	Capacity (gal.)	A inches (mm)	B inches (mm)	Ø (D) inches (mm)
LSG60	4.5	22 ³ / ₄ x 6 ¹¹ / ₁₆ (596 x 170)	14 ¹ / ₂ (368)	2 ³ / ₈ (60)
LSG75	4.5	22 ³ / ₄ x 6 ¹¹ / ₁₆ (596 x 170)	14 ¹ / ₂ (368)	3 (75)
LSG90	4.5	22 ³ / ₄ x 6 ¹¹ / ₁₆ (596 x 170)	14 ¹ / ₂ (368)	3 ¹ / ₂ (90)

Check valve (incorporated)

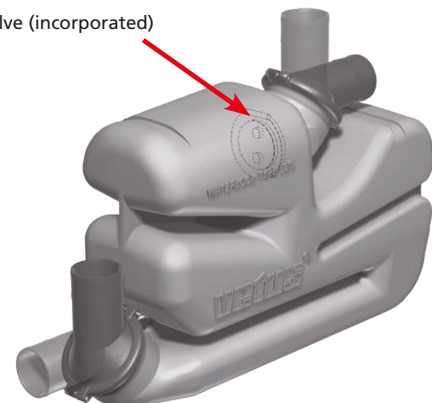

LSG

DUAL STAGE WATERLOCKS

Type NLP

Superior silencing, minimal back pressure

Our NLP waterlocks are of dual stage construction featuring upper and lower chambers with a horizontal partition plate and a riser tube through the centre. The installation of the exhaust system, even in confined engine spaces, is greatly simplified due to the 360° rotating top chamber and rotating inlet and outlet connectors. For optimum silencing of exhaust noise you can also use a VETUS muffler and gooseneck, after the waterlock.

Including mounting brackets for bulkhead or floor mounting

Type	NLP40 inch (mm)	NLP45 inch (mm)	NLP50 inch (mm)	NLP50S inch (mm)	NLP60 inch (mm)	NLP75 inch (mm)	NLP90 inch (mm)
A	7 ⁵ / ₁₆ (186)	7 ⁵ / ₁₆ (186)	7 ⁵ / ₁₆ (186)	9 ⁷ / ₁₆ (240)	9 ⁷ / ₁₆ (240)	9 ⁷ / ₁₆ (240)	9 ⁷ / ₁₆ (240)
B	2 (50.5)	2 (50.5)	2 (50.5)	3 (75.5)	3 (75.5)	3 (75.5)	3 (75.5)

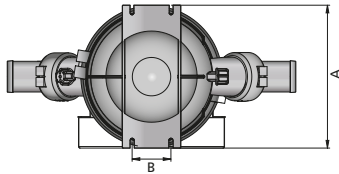

Specifications

- Type NLP40/45/50 has an exhaust hose with inside diameter of \varnothing 1⁹/₁₆" , 1³/₄" or 2" (40, 45 or 50 mm) with a capacity of 1.2 gal. (4,5 litres)
- Type NLP60/75/90/50S has an exhaust hose with inside diameter of \varnothing 2" , 2³/₈" , 3" or 3¹/₂" (50, 60, 75 or 90 mm) with a capacity of 2.6 gal. (10 litres)
- Comes with 2 securing straps

Type	Capacity gal. (litre)	A inch (mm)	B inch (mm)	\varnothing (C) (mm)	\varnothing (D) (mm)
NLP40	1,2 (4,5)	15 ⁵ / ₃₂ (385)	10 (254)	6 ¹ / ₂ (165)	1 ⁹ / ₁₆ (40)
NLP45	1,2 (4,5)	15 ⁵ / ₃₂ (385)	10 (254)	6 ¹ / ₂ (165)	1 ³ / ₄ (45)
NLP50	1,2 (4,5)	15 ⁵ / ₃₂ (385)	10 (254)	6 ¹ / ₂ (165)	2 (50)
NLP50S	2,6 (10)	20 ⁹ / ₃₂ (515)	14 ¹ / ₄ (362)	8 ¹⁷ / ₆₄ (210)	2 (50)
NLP60	2,6 (10)	20 ⁹ / ₃₂ (515)	14 ¹ / ₄ (362)	8 ¹⁷ / ₆₄ (210)	2 ³ / ₈ (60)
NLP75	2,6 (10)	20 ⁹ / ₃₂ (515)	14 ¹ / ₄ (362)	8 ¹⁷ / ₆₄ (210)	3 (75)
NLP90	2,6 (10)	20 ⁹ / ₃₂ (515)	14 ¹ / ₄ (362)	8 ¹⁷ / ₆₄ (210)	3 ¹ / ₂ (90)

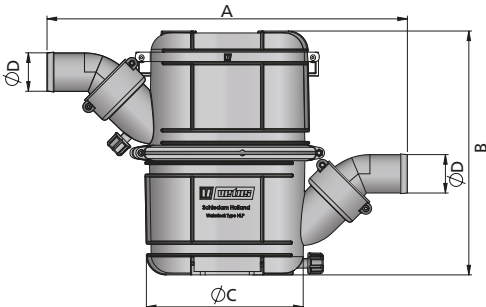

NLP50S*
NLP

Dimensions: plus or minus 2%
* Capacity of 10 litres, \varnothing 50 mm

WATERLOCK/MUFFLER

Designed for horizontal installation

The body of this waterlock / muffler consists of 2 rotatable chambers and fully rotatable hose connections, ensuring simple and time saving installation in a wide range of applications.

Type NLPH

Suitable for a wide range of applications

- Suitable for $\text{Ø } 1\frac{9}{16}"$, $1\frac{3}{4}"$, $2"$, $2\frac{3}{8}"$, $3"$ or $3\frac{1}{2}"$ (40, 45, 50, 60, 75 or 90 mm) internal hose diameters
- Comes with 2 securing straps

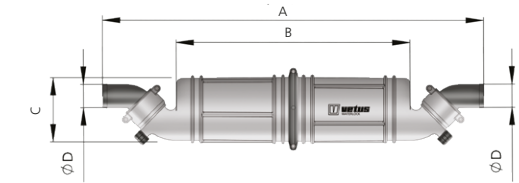
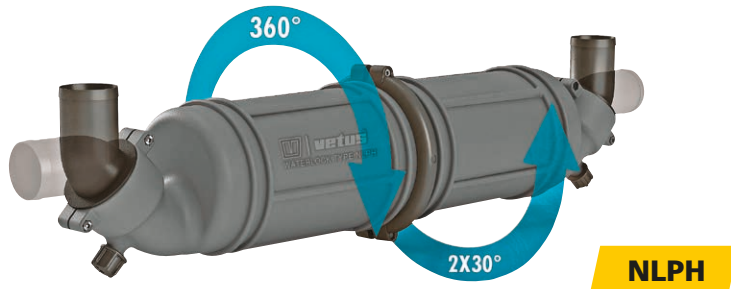

Type 40, 45, 50

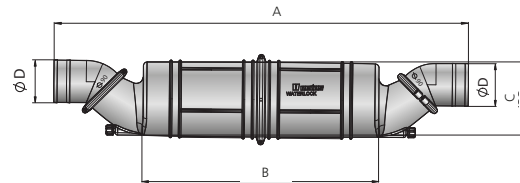

Type 60, 75, 90

Type	Capacity gal.	A inch (mm)	B inch (mm)	C inch (mm)	Ø (D) inch (mm)
NLPH40	0.8	25 ⁴³ / ₆₄ (652)	15 ³ / ₄ (400)	4 ²¹ / ₆₄ (110)	1 ⁹ / ₁₆ (40)
NLPH45	0.8	25 ⁴³ / ₆₄ (652)	15 ³ / ₄ (400)	4 ²¹ / ₆₄ (110)	1 ³ / ₄ (45)
NLPH50	0.8	25 ⁴³ / ₆₄ (652)	15 ³ / ₄ (400)	4 ²¹ / ₆₄ (110)	2 (50)
NLPH60	2.6	34 ³⁹ / ₆₄ (879)	19 ¹¹ / ₁₆ (500)	6 ⁷ / ₆₄ (155)	2 ³ / ₈ (60)
NLPH75	2.6	34 ³⁹ / ₆₄ (879)	19 ¹¹ / ₁₆ (500)	6 ⁷ / ₆₄ (155)	3 (75)
NLPH90	2.6	34 ³⁹ / ₆₄ (879)	19 ¹¹ / ₁₆ (500)	6 ⁷ / ₆₄ (155)	3 ¹ / ₂ (90)

Type NLP3

The quietest waterlock in the world!

Due to its unique three chamber technology it has a sound reduction of an incredible 10dB more than the traditional waterlocks. Its rotatable chambers and hose connections ensure a quick and simple installation even in the most confined spaces.

- Suitable for hose connections to suit internal diameters of $\text{Ø } 1\frac{9}{16}"$, $1\frac{3}{4}"$, $2"$, $2\frac{3}{8}"$, $3"$ or $3\frac{1}{2}"$ (40, 45, 50, 60, 75 or 90 mm)
- Comes with 2 securing straps

Type	Capacity gal.	A inch (mm)	B inch (mm)	C inch (mm)	Ø (D) inch (mm)
NLP340	1.3	30 ²⁵ / ₆₄ (772)	20 ¹⁵ / ₃₂ (520)	4 ²¹ / ₆₄ (110)	1 ⁹ / ₁₆ (40)
NLP345	1.3	30 ²⁵ / ₆₄ (772)	20 ¹⁵ / ₃₂ (520)	4 ²¹ / ₆₄ (110)	1 ³ / ₄ (45)
NLP350	1.3	30 ²⁵ / ₆₄ (772)	20 ¹⁵ / ₃₂ (520)	4 ²¹ / ₆₄ (110)	2 (50)
NLP360	3.4	41 ¹¹ / ₃₂ (1050)	26 ³ / ₈ (670)	6 ⁷ / ₆₄ (155)	2 ³ / ₈ (60)
NLP375	3.4	41 ¹¹ / ₃₂ (1050)	26 ³ / ₈ (670)	6 ⁷ / ₆₄ (155)	3 (75)
NLP390	3.4	41 ¹¹ / ₃₂ (1050)	26 ³ / ₈ (670)	6 ⁷ / ₆₄ (155)	3 ¹ / ₂ (90)
NLP31560	15	47 ¹ / ₄ (1200)	32 ³¹ / ₆₄ (825)	6 ⁷ / ₆₄ (155)	2 ³ / ₈ (60)
NLP31575	15	47 ¹ / ₄ (1200)	32 ³¹ / ₆₄ (825)	6 ⁷ / ₆₄ (155)	3 (75)
NLP31590	15	47 ¹ / ₄ (1200)	32 ³¹ / ₆₄ (825)	6 ⁷ / ₆₄ (155)	3 ¹ / ₂ (90)



NLP3

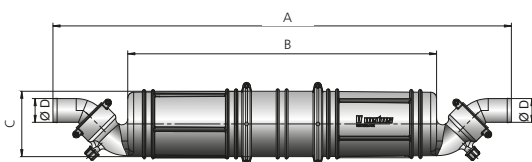

Type 40, 45, 50

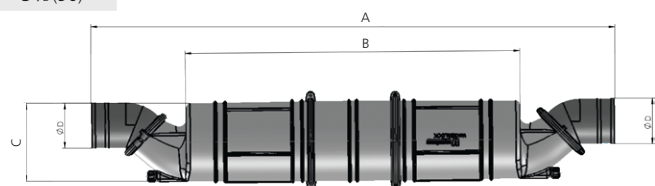

Type 60, 75, 90

WATERLOCKS SPECIFICALLY FOR LARGER BOATS

Excellent sound reduction, minimal back pressure

This type of waterlock is designed for modern high performance boats with one or two large engines which have little space to spare in the engine room. The outlet connection at the top can rotate through 360° and the inlet connection is at an angle of 45° upward. Type MG can only be installed in water injected exhaust systems. Its body is entirely made of synthetic materials, therefore not susceptible to corrosion or galvanic action.

Type MG

Specifications

- Excellent sound reduction
- Minimal back pressure
- Drain valve for winter storage
- Suitable for Ø 3½", 4", 5", 6", 8" (90, 102, 127, 152, 209 or 250 mm) internal hose diameters
- Capacities of 6.08, 19.8 or 34.3 gallon (23, 75 or 130 litres)
- Comes with stainless steel (AISI 316) clamp bands

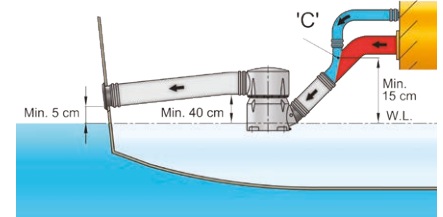

Type	Ø d inch (mm)	Ø D inch (mm)	Ø A inch (mm)	B inch (mm)	Capacity (gal.)
MGP9090	3½ (90)	3½ (90)	10⅝ (270)	17 ²³ / ₃₂ (450)	6.08
MGP102102	4 (102)	4 (102)	10⅝ (270)	17 ²³ / ₃₂ (450)	6.08
MGP5455	5 (127)	5 (127)	10⅝ (270)	17 ²³ / ₃₂ (450)	6.08
MGP102127	4 (102)	5 (127)	10⅝ (270)	17 ²³ / ₃₂ (450)	6.08

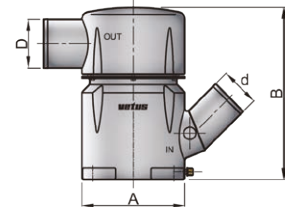

MGP



Type	Ø d inch (mm)	Ø D inch (mm)	Ø A inch (mm)	B inch (mm)	Capacity (gal.)
MGS5455A	5 (127)	5 (127)	15¾ (400)	27 ⁹ / ₁₆ (700)	19.8
MGS5456A	5 (127)	6 (152)	15¾ (400)	27 ⁹ / ₁₆ (700)	19.8
MGS6456A	6 (152)	6 (152)	15¾ (400)	27 ⁹ / ₁₆ (700)	19.8

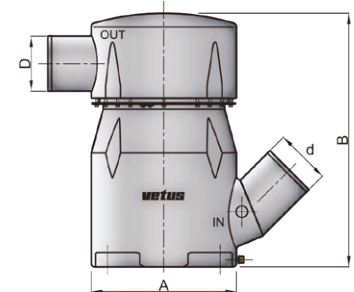

MGS



Type	Ø d inch (mm)	Ø D inch (mm)	Ø A inch (mm)	B inch (mm)	Capacity (gal.)
MGL6458A	6 (152)	8 (203)	19 ¹¹ / ₁₆ (500)	29 ¹⁷ / ₃₂ (750)	34.3
MGL8458A	8 (203)	8 (203)	19 ¹¹ / ₁₆ (500)	29 ¹⁷ / ₃₂ (750)	34.3
MGL84510A	8 (203)	9 ²⁷ / ₃₂ (250)	19 ¹¹ / ₁₆ (500)	29 ¹⁷ / ₃₂ (750)	34.3

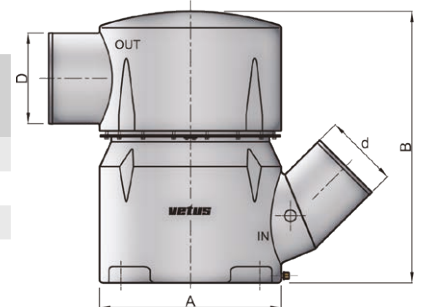

MGL

Flexible mountings for waterlocks, see page 100.

Note

For a minimum order of 10 pieces, we can supply these waterlocks with inlet or outlet connection at an angle of 0°, 15° or 30°.

WATERLOCKS SPECIFICALLY FOR COMMERCIAL BOATS

Heavy Duty Line

Heavy duty waterlocks

Made of the special blended composite NAVIDURIN® - which is temperature resistant up to 500°F (260°C) - these Heavy Duty waterlocks outperform standard GRP materials by 170%! The same applies for the thermal resistance to deformation under pressure. We offer two types of HD waterlocks; the NLPHD (1.2 - 2.6 gallon / 4.5 - 10 litres) and the HPW (14.5 gallon / 55 litres).

The NLP waterlock design is already known for its extraordinary noise reduction features, versatile installation options and extremely low back pressure. Made from NAVIDURIN®, this product can meet any challenge. The Heavy Duty Line is therefore unique in this market!

The HPW series is perfect for applications where the system is put to the test such as commercial or coastguard vessels.

For specifications see next page.



Specifications	VETUS Heavy Duty Composite (NAVIDURIN®)	GRP	Class 1 Epoxy Vinyl Ester resin
Material temperature resistance	500°F (260°C)	302°F (150°C)	345°F (174°C)
Continuous operating temperature	356°F (180°C)	248°F (120°C)	284°F (140°C)
Maximum operating temperature	482°F (250°C)	302°F (150°C)	345°F (174°C)
Temperature for deflection under load (1.8 MPa, 18 Bar, 260 psi)	482°F (250°C)	248°F (120°C)	284°F (140°C)
Tensile strength	190 Mpa 1900 Bar 27,560 psi	100 Mpa 1000 Bar 14500 psi	114 Mpa 1140 Bar 16,530 psi
Flexural strength	300 Mpa 3000 Bar 43,500 psi	140 Mpa 1400 Bar 20,300 psi	167 Mpa 1670 Bar 24,200 psi

WATERLOCKS SPECIFICALLY FOR COMMERCIAL BOATS

NLPHD

Specifications

- Suitable for \varnothing 1 $\frac{9}{16}$ " , 1 $\frac{3}{4}$ " , 2" , 2 $\frac{3}{8}$ " , 3" , 3 $\frac{1}{2}$ " (40, 45, 50, 60, 75 and 90 mm internal hose diameters)
- Special composite blend (NAVIDURIN®) is capable of handling temperatures up to 500°F (260°C)
- 360° Rotating bodies and hose connections
- Comes with floor and bulkhead mounting brackets



NLPHD

Type	Colour	Hose \varnothing inch (mm)	Capacity (litres)	Drawing S inch			Drawing L inch		
				A	B	C	A	B	C
NLP40HD	Black	1 $\frac{9}{16}$ (40)	1.2 Ga (4.5 L)	15 $\frac{5}{32}$	10	6 $\frac{1}{2}$			
NLP45HD	Black	1 $\frac{3}{4}$ (45)	1.2 Ga (4.5 L)	15 $\frac{5}{32}$	10	6 $\frac{1}{2}$			
NLP50HD	Black	2 (50)	1.2 Ga (4.5 L)	15 $\frac{5}{32}$	10	6 $\frac{1}{2}$			
NLP50SHD	Black	2 (50)	2.6 Gal (10 L)				20 $\frac{9}{32}$	14 $\frac{1}{4}$	8 $\frac{17}{64}$
NLP60HD	Black	2 $\frac{3}{8}$ (60)	2.6 Gal (10 L)				20 $\frac{9}{32}$	14 $\frac{1}{4}$	8 $\frac{17}{64}$
NLP75HD	Black	3 (75)	2.6 Gal (10 L)				20 $\frac{9}{32}$	14 $\frac{1}{4}$	8 $\frac{17}{64}$
NLP90HD	Black	3 $\frac{1}{2}$ (90)	2.6 Gal (10 L)				20 $\frac{9}{32}$	14 $\frac{1}{4}$	8 $\frac{17}{64}$
NLP40WHD	White*	1 $\frac{9}{16}$ (40)	1.2 Ga (4.5 L)	15 $\frac{5}{32}$	10	6 $\frac{1}{2}$			
NLP45WHD	White*	1 $\frac{3}{4}$ (45)	1.2 Ga (4.5 L)	15 $\frac{5}{32}$	10	6 $\frac{1}{2}$			
NLP50WHD	White*	2 (50)	1.2 Ga (4.5 L)	15 $\frac{5}{32}$	10	6 $\frac{1}{2}$			
NLP50SWHD	White*	2 (50)	2.6 Gal (10 L)				20 $\frac{9}{32}$	14 $\frac{1}{4}$	8 $\frac{17}{64}$
NLP60WHD	White*	2 $\frac{3}{8}$ (60)	2.6 Gal (10 L)				20 $\frac{9}{32}$	14 $\frac{1}{4}$	8 $\frac{17}{64}$
NLP75WHD	White*	3 (75)	2.6 Gal (10 L)				20 $\frac{9}{32}$	14 $\frac{1}{4}$	8 $\frac{17}{64}$
NLP90WHD	White*	3 $\frac{1}{2}$ (90)	2.6 Gal (10 L)				20 $\frac{9}{32}$	14 $\frac{1}{4}$	8 $\frac{17}{64}$

* Available in white on special order

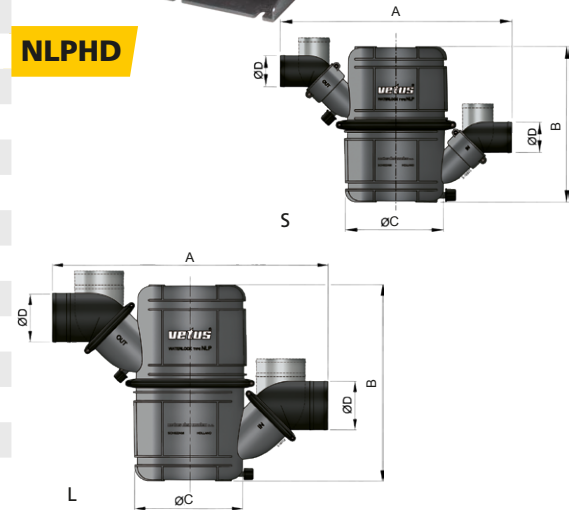

HPW

Specifications

- Suitable for \varnothing 4 $\frac{1}{64}$, 5 and 5 $\frac{63}{64}$ " (102, 127 and 152 mm) internal hose diameters
- Special composite blend (NAVIDURIN®) is capable of handling temperatures up to 500°F (260°C)
- High capacity waterlift design providing complete security for your engine
- Excellent sound attenuation with minimal back pressure
- Rotating body and hose connections for easy installation
- Complete with floor mounting brackets



HPW

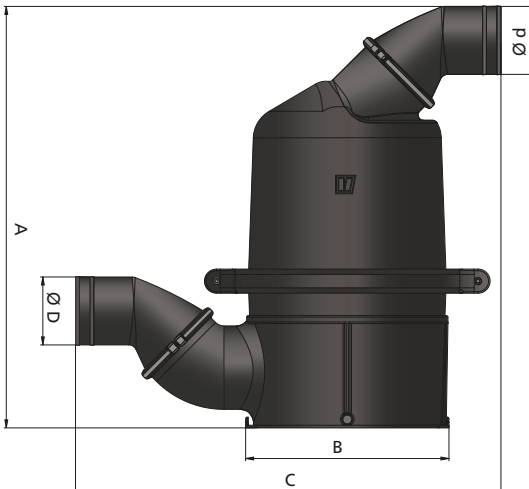

Type	Colour	\varnothing D inche (mm)	\varnothing d inch (mm)	Capacity (gal.)	A inches	B inches	C inches
HPW102	Black	4 (102)	4 (102)	14.5	31 $\frac{1}{32}$	14 $\frac{61}{64}$	31 $\frac{19}{64}$
HPW127	Black	5 (127)	5 (127)	14.5	31 $\frac{1}{32}$	14 $\frac{61}{64}$	31 $\frac{19}{64}$
HPW152	Black	6 (152)	6 (152)	14.5	31 $\frac{1}{32}$	14 $\frac{61}{64}$	31 $\frac{19}{64}$
HPW127152	Black	5 (127)	6 (152)	14.5	31 $\frac{1}{32}$	14 $\frac{61}{64}$	31 $\frac{19}{64}$

EXHAUST SYSTEMS FOR HIGH-PERFORMANCE CRAFT

Especially developed for fast craft with powerful engines

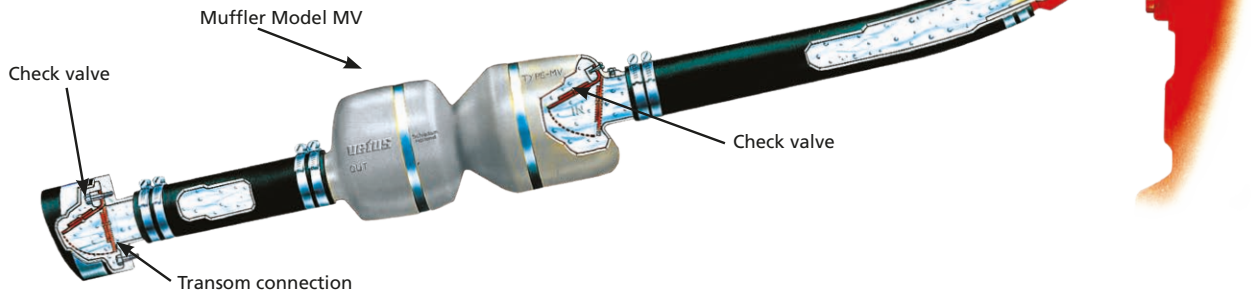

This system is perfect for fast craft with powerful engines without available space for installation of a waterlock and/or gooseneck. By using one of these compact mufflers, you have tremendous reduction of exhaust noise with minimal back pressure. All parts are made of synthetic materials, corrosion free and light weight.

The transom connections for this system are available in stainless steel (AISI 316) or reinforced black plastic. Waterlock type MV and the transom connection are provided with a check valve which prevents the seawater from flowing into the engine.

Type MV

Specifications

- For hose diameters \varnothing 3 1/2", 4", 5" and 6" (90, 100, 125 and 150 mm)
- Comes with stainless steel (AISI 316) mounting brackets
- Temperature sensor for a raw water alarm is optional (recommended)
See page 98

Type	\varnothing D inch (mm)	\varnothing H inch (mm)	L inch (mm)	Capacity (gal.)
MV090	3 1/2" (90)	8 1/16" (210)	27 19/32" (702)	3
MV100	4" (100)	8 1/16" (210)	27 19/32" (702)	3
MV125	5" (125)	12 19/32" (320)	35 13/16" (910)	9.8
MV150	6" (150)	12 19/32" (320)	35 13/16" (910)	9.8

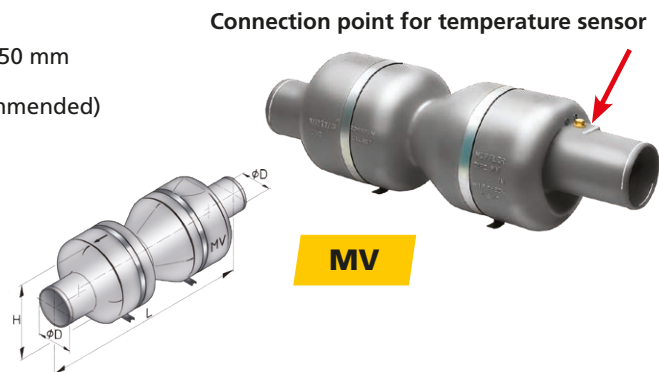

Type MF

Specifications

- For hose diameters \varnothing 3 1/2", 4", 5" and 6" (90, 102, 127 and 152 mm)
- Comes with stainless steel (AISI 316) mounting brackets

Type	\varnothing D inch (mm)	\varnothing inch (mm)	L inch (mm)	Capacity (gal.)
MF090	3 1/2" (90)	8 1/16" (210)	28 19/32" (728)	3.5
MF100	4" (102)	8 1/16" (210)	28 15/16" (735)	3.5
MF125	5" (127)	12 19/32" (320)	37" (940)	11.5
MF150	6" (152)	12 19/32" (320)	37 13/16" (959)	11.5

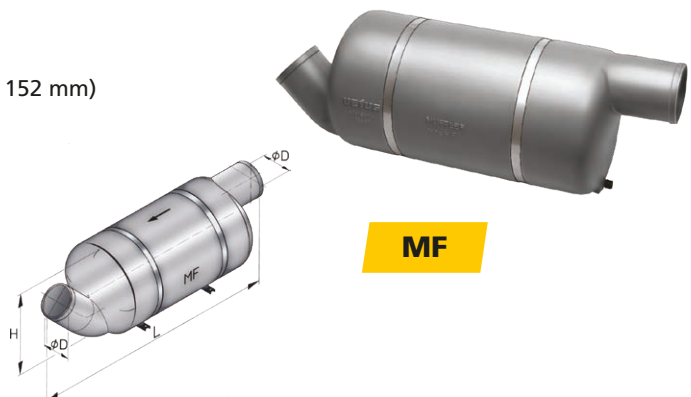

Note

Both types should be installed exclusively in combination with an approved reinforced rubber exhaust hose (see page 406).



MUFFLER

Type DEMPMP

Better noise reduction

The construction of this muffler causes almost no resistance to the free flow of the exhaust gases. It creates additional mixing of the water inside the exhaust line which results in even better noise reduction.

- Suitable for \varnothing 1 $\frac{9}{16}$ "", 1 $\frac{3}{4}$ "", 2", 2 $\frac{3}{8}$ "", 3", 3 $\frac{1}{2}$ " or 4" (40, 45, 50, 60, 75, 90 or 102 mm) internal hose diameters

Type	A inch (mm)	B inch (mm)	\varnothing D inch (mm)
DEMPMP40	14 $\frac{1}{2}$ x 4 $\frac{1}{4}$ (368 x 108)	6 $\frac{1}{4}$ (158)	1 $\frac{9}{16}$ (40)
DEMPMP45	14 $\frac{1}{2}$ x 4 $\frac{1}{4}$ (368 x 108)	6 $\frac{1}{4}$ (158)	1 $\frac{3}{4}$ (45)
DEMPMP50	14 $\frac{1}{2}$ x 4 $\frac{1}{4}$ (368 x 108)	6 $\frac{1}{4}$ (158)	2 (51)
DEMPMP60	14 $\frac{1}{2}$ x 4 $\frac{1}{4}$ (368 x 108)	6 $\frac{1}{4}$ (158)	2 $\frac{3}{8}$ (60)
DEMPMP76	17 $\frac{15}{16}$ x 5 $\frac{1}{8}$ (456 x 130)	7 $\frac{1}{16}$ (180)	3 (76)
DEMPMP90	17 $\frac{15}{16}$ x 5 $\frac{1}{8}$ (456 x 130)	6 $\frac{1}{4}$ (158)	3 $\frac{1}{2}$ (90)
DEMPMP100	22 $\frac{13}{16}$ x 6 $\frac{5}{8}$ (580 x 168)	6 $\frac{1}{4}$ (158)	4 (102)

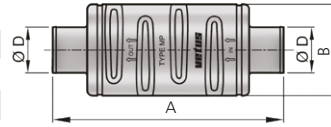

DEMPMP

MUFFLER AND GOOSENECK

Type NLPG

Perfect combination of a muffler and gooseneck

Combining the functions of a muffler and gooseneck saves installation time and space while maintaining the essential qualities of a good exhaust system with impressive negligible back pressure. The gooseneck prevents water back filling the exhaust and the muffler creates additional water mixing to further reduce the exhaust noise.

Specifications

- Suitable for exhaust hose with internal diameter of \varnothing 1 $\frac{9}{16}$ "", 1 $\frac{3}{4}$ "", 2", 2 $\frac{3}{8}$ "", 3" or 3 $\frac{1}{2}$ " (40, 45, 51, 60, 75 or 90 mm)
- Fully rotatable sections and hose connections to ensure easy installation
- Comes with a hose stub to connect the air vent

Type	Capacity (gal.)	A inch (mm)	B inch (mm)	\varnothing C inch (mm)	\varnothing (D) inch (mm)	E inch (mm)	\varnothing F inch (mm)
NLPG40	0.8	15 $\frac{3}{16}$ (385)	15 $\frac{3}{4}$ (400)	4 $\frac{5}{16}$ (110)	1 $\frac{9}{16}$ (40)	19 $\frac{29}{64}$ (494)	4 $\frac{5}{16}$ (110)
NLPG45	0.8	15 $\frac{3}{16}$ (385)	15 $\frac{3}{4}$ (400)	4 $\frac{5}{16}$ (110)	1 $\frac{3}{4}$ (45)	19 $\frac{29}{64}$ (494)	4 $\frac{5}{16}$ (110)
NLPG50	0.8	15 $\frac{3}{16}$ (385)	15 $\frac{3}{4}$ (400)	4 $\frac{5}{16}$ (110)	2 (51)	19 $\frac{29}{64}$ (494)	4 $\frac{5}{16}$ (110)
NLPG60	2.6	15 $\frac{15}{16}$ (405)	19 $\frac{11}{16}$ (500)	11 $\frac{15}{64}$ (285,3)	2 $\frac{3}{8}$ (60)	25 $\frac{29}{64}$ (646,4)	6 $\frac{19}{64}$ (160)
NLPG75	2.6	15 $\frac{15}{16}$ (405)	19 $\frac{11}{16}$ (500)	11 $\frac{15}{64}$ (285,3)	3 (75)	25 $\frac{29}{64}$ (646,4)	6 $\frac{19}{64}$ (160)
NLPG90	2.6	15 $\frac{15}{16}$ (405)	19 $\frac{11}{16}$ (500)	11 $\frac{15}{64}$ (285,3)	3 $\frac{1}{2}$ (90)	25 $\frac{29}{64}$ (646,4)	6 $\frac{19}{64}$ (160)

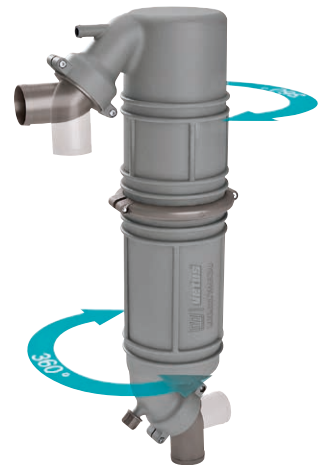

NLPG

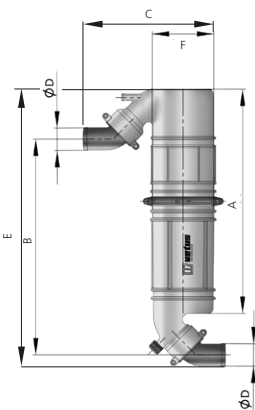

Type NLPG40 - 45 - 50

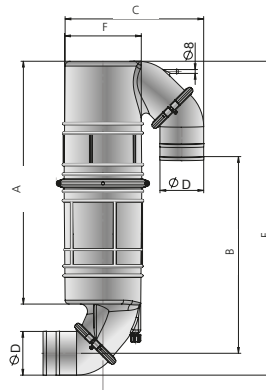

Type NLPG60 - 75 - 90

GOOSENECK

The gooseneck raises the exhaust line above the waterline and provides additional noise reduction. The outlet fits directly to all VETUS rubber transom connectors.

Type WLOCKLT

This gooseneck is suitable for an exhaust hose with an internal diameter of $\varnothing 1\frac{9}{16}$ ", $1\frac{3}{4}$ ", 2" or $2\frac{3}{8}$ " (40, 45, 51 or 60 mm). Engines with a $2\frac{1}{4}$ " (57 mm) exhaust elbow can be connected to a $2\frac{3}{8}$ " (60 mm) VETUS exhaust hose and use $2\frac{3}{8}$ " (60 mm) exhaust components.

Type	A inch (mm)	B inch (mm)	\varnothing D inch (mm)
WLOCKLT40	19 $\frac{3}{4}$ x 5 $\frac{5}{16}$ (502 x 135)	7 $\frac{11}{64}$ (182)	1 $\frac{9}{16}$ (40)
WLOCKLT45	19 $\frac{3}{4}$ x 5 $\frac{5}{16}$ (502 x 135)	7 $\frac{11}{64}$ (182)	1 $\frac{3}{4}$ (45)
WLOCKLT50	19 $\frac{3}{4}$ x 5 $\frac{5}{16}$ (502 x 135)	7 $\frac{11}{64}$ (182)	2 (51)
WLOCKLT60	19 $\frac{3}{4}$ x 5 $\frac{5}{16}$ (502 x 135)	7 $\frac{11}{64}$ (182)	2 $\frac{3}{8}$ (60)

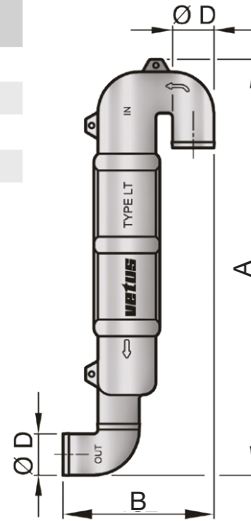

WLOCKLT

Type LT

This type is suitable for an exhaust hose with an internal diameter of $\varnothing 3$ ", $3\frac{1}{2}$ ", 4", 5" or 6" (76, 90, 102, 127 or 152 mm). Supplied with stainless steel (AISI 316) mounting brackets.

Type	L inch (mm)	H inch (mm)	B inch (mm)	\varnothing D inch (mm)
LT 65	6 $\frac{1}{8}$ (155)	19 $\frac{3}{4}$ (500)	9 $\frac{1}{4}$ (235)	3 (65)
LT 75	6 $\frac{1}{8}$ (155)	19 $\frac{3}{4}$ (500)	9 $\frac{1}{4}$ (235)	3 (75)
LT 90	8 $\frac{1}{4}$ (210)	20 $\frac{3}{4}$ (525)	11 $\frac{1}{8}$ (300)	3 $\frac{1}{2}$ (90)
LT 102	8 $\frac{1}{4}$ (210)	20 $\frac{3}{4}$ (525)	11 $\frac{1}{8}$ (300)	4 (102)
LT 110	8 $\frac{1}{4}$ (210)	20 $\frac{3}{4}$ (525)	11 $\frac{1}{8}$ (300)	4 $\frac{5}{16}$ (110)
LT 127	10 $\frac{7}{8}$ (275)	22 $\frac{1}{4}$ (565)	15 (380)	5 (127)
LT 152	10 $\frac{7}{8}$ (275)	22 $\frac{1}{4}$ (565)	15 (380)	6 (152)

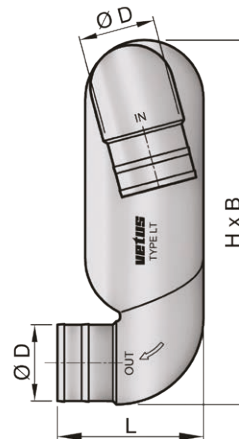

LT



AIRVENTS

Anti-siphoning

When the cooling water injection point is less than 6" (15 cm) above the waterline, the cooling system can siphon water through the intake when the engine is turned off. Water can siphon into the exhaust system and even into the engine itself. This can be prevented by using an air vent.

Type ASDV with pressure valve

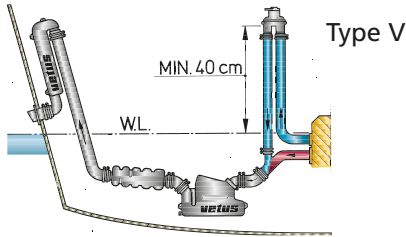

Type ASDH with ventilation hose

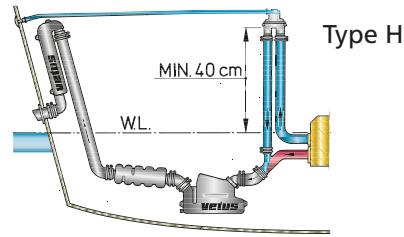

Type ASDV with pressure valve

Less maintenance is needed

This air vent is made of synthetic material and is exchangeable with type AIRVENT due to the same fixing holes centres. It has a silicone anti-siphon pressure valve and is self-contained.

Specifications

- Types ASDV and type AIRVENTV are suitable for hose connections with an internal diameter of $\text{\O} \frac{1}{2}$ ", $\frac{3}{4}$ ", 1" and $1\frac{1}{4}$ " (13, 19, 25 and 32 mm)
- Type ASD38V has a hose connection with an internal diameter of $\text{\O} 1\frac{1}{2}$ " (38 mm) and is ideal for toilets or holding tanks which are installed below the waterline

Type ASDH with ventilation hose

Constant bleed of cooling water

This air vent has a hose connection to the outside of the hull and has a constant bleed of cooling water through the hose while the engine is running. Type H comes with a skin fitting, hose clamps and 4 metres of hose.

Specifications

- Types ASDH and type AIRVENTH are suitable for $\text{\O} \frac{1}{2}$ ", $\frac{3}{4}$ ", 1" and $1\frac{1}{4}$ " (13, 19, 25 and 32 mm) internal hose connections
- Type ASD38H has a $\text{\O} 1\frac{1}{2}$ " (38 mm) hose connection and is ideal for toilets or holding tanks which are installed below the waterline



Type		Ø Hose inch (mm)
ASDV	Anti Syphon Device with Valve	$\frac{1}{2}$ / $\frac{3}{4}$ / 1 / $1\frac{1}{4}$ (13 / 19 / 25 / 32)
ASDH	Anti Syphon Device with Hose	$\frac{1}{2}$ / $\frac{3}{4}$ / 1 / $1\frac{1}{4}$ (13 / 19 / 25 / 32)

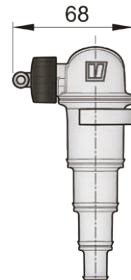
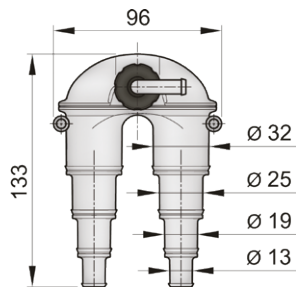

ASDV



ASDH



AIRVENTS

Type ASD

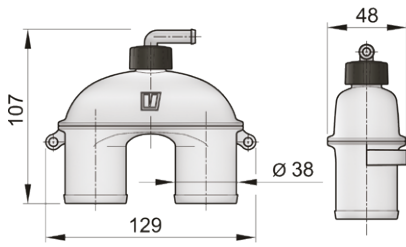

ASD38V

ASD38H

Type		Ø Hose inch (mm)
ASD38V	Anti Syphon Device with Valve	1 1/2 (38)
ASD38H	Anti Syphon Device with Hose	1 1/2 (38)

Type AIRVENT

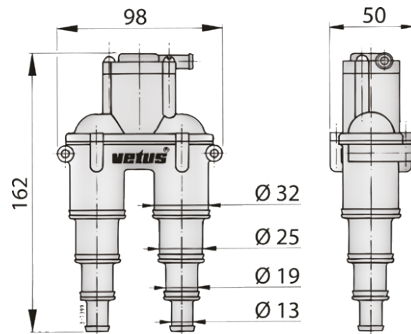

AIRVENTV



AIRVENTH

Type		Ø Hose inch (mm)
AIRVENTV	Air vent with Valve	1/2 / 3/4 / 1 / 1 1/4 (13 / 19 / 25 / 32)
AIRVENTH	Air vent with Hose	1/2 / 3/4 / 1 / 1 1/4 (13 / 19 / 25 / 32)

For both model ASD and AIRVENT a mounting bracket is available to facilitate installation onto surfaces clad with sound insulation (see page 60). This mounting bracket is supplied with bolts, washers and self-locking nuts to mount the airvent.



GAS / WATER SEPARATOR

For marine engines and generator sets

The VETUS gas / water separator has a double function. It separates the injected raw cooling water from the exhaust gases and also functions as a gooseneck. Particularly important for generator sets, the separator reduces the exhaust noise and drains the cooling water below the waterline, thus preventing the characteristic splashing sound.

Type LGS 40/45/50/60/75/90

Specifications

- 360° Rotating hose connections for 1⁹/₁₆" , 1³/₄" , 2" , 2³/₈" , 3" or 3¹/₂" (40, 45, 51, 60, 76 or 91 mm) internal hose diameters
- Cooling water drain of 1¹/₂" (38 mm) or 2" (51 mm)
- Comes with stainless steel (AISI 316) mounting bracket with synthetic straps

Type	A inch (mm)	B inch (mm)	Ø D inch (mm)	Capacity (gal.)
LGS4038	16 x 5 ⁹ / ₃₂ (406 x 134)	14 ⁹ / ₁₆ (370)	1 ⁹ / ₁₆ (40)	1.8
LGS4538	16 x 5 ⁹ / ₃₂ (406 x 134)	14 ⁹ / ₁₆ (370)	1 ³ / ₄ (45)	1.8
LGS5038	16 x 5 ⁹ / ₃₂ (406 x 134)	14 ⁹ / ₁₆ (370)	2 (51)	1.8
LGS6050	21 ¹⁷ / ₆₄ x 6 ¹ / ₁₆ (540 x 170)	16 ¹ / ₃₂ (420)	2 ³ / ₈ (60)	3
LGS7550	21 ¹⁷ / ₆₄ x 6 ¹ / ₁₆ (540 x 170)	16 ¹ / ₃₂ (420)	3 (76)	3
LGS9075	22 ¹ / ₆₄ x 6 ¹ / ₁₆ (559 x 170)	21 ⁹ / ₆₄ (537)	3 ¹ / ₂ (91)	5.3



LGS

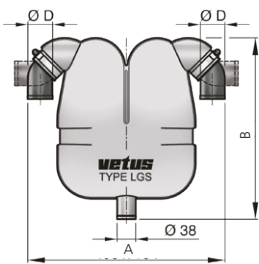

Type LGS40 - 45 - 50

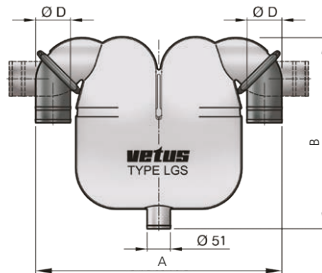

Type LGS60 - 75 - 90

EXHAUST TEMPERATURE ALARM

Safety first. Always place an alarm in the exhaust line!

A blockage in the engine water intake or a damaged pump impeller will result in a complete loss, or severe reduction in the volume of cooling water in the exhaust system. In this case the temperature in the exhaust will rise much faster than the temperature of the engine. VETUS always recommends placing an exhaust temperature alarm that provides a visual and audible alarm when the temperature inside the exhaust hose or the muffler exceeds an acceptable level.

Specifications

- Alarm cut-out dimension Ø 2¹/₁₆" (52 mm), overall diameter 2⁷/₁₆" (62 mm)
- Build-in depth 1⁹/₁₆" (40 mm)
- Suitable for 12 or 24 Volt D.C.
- Use sensor XHSM in VETUS waterlocks that have a pre-installed connection
- Use sensor type XSHS for fitting in the exhaust hose

Note

The temperature sensors and the alarm unit must be ordered separately. In case of a twin engine installation, 2 sensors can be connected to 1 alarm unit.

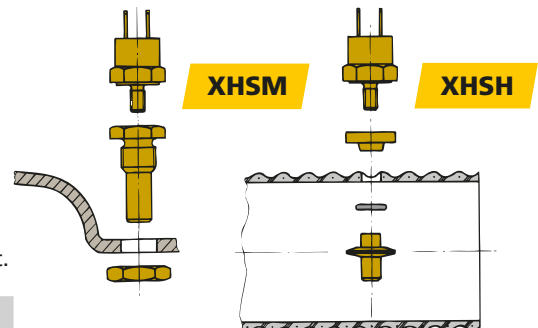

Type		Colour
XHI12B	Dashboard instrument for exhaust temperature alarm 12 V	Black
XHI24B	Dashboard instrument for exhaust temperature alarm 24 V	Black
XHI12W	Dashboard instrument for exhaust temperature alarm 12 V	Cream
XHI24W	Dashboard instrument for exhaust temperature alarm 24 V	Cream
XHSM	Sensor for exhaust temperature alarm to fit MF/MV/LSG/LSS/MGS/MGL/MGP/HPW	
XHSH	Sensor for exhaust temperature alarm to fit exhaust hose	



XHI

TRANSOM EXHAUST CONNECTIONS

Easy mounting to transom

Type TRCR

The flexible EPDM rubber connector is mounted to the outside of the transom with a $\frac{3}{32}$ " (2 mm) thick stainless steel (AISI 316) mounting ring. VETUS mufflers and goosenecks with corresponding dimensions fit directly into the rubber sleeve. For connection of the exhaust hose, a plastic connector type SLVBR or SLVBG is required (see page 100).



TRCR

Type	For exhaust hose (I.D.) inch (mm)	A = hole size Ø inch (mm)	Ø B inch (mm)	C inch (mm)
TRC40R	1 ⁹ / ₁₆ (40)	2 ¹ / ₈ (53)	3 ²⁵ / ₆₄ (86)	3 ²⁵ / ₆₄ (86)
TRC45R	1 ³ / ₄ (45)	2 ¹ / ₈ (58)	4 ¹ / ₂ (114)	3 ²⁵ / ₆₄ (86)
TRC50R	2 (51)	2 ¹ / ₂ (63)	4 ¹ / ₂ (114)	3 ²⁵ / ₆₄ (86)
TRC60R	2 ³ / ₈ (60)	2 ⁷ / ₈ (73)	4 ¹ / ₂ (114)	3 ²⁵ / ₆₄ (86)
TRC7590R	3 (76) and 3 ¹ / ₂ (90)	4 ³ / ₈ (111)	6 ⁷ / ₁₆ (164)	3 ¹ / ₂ (90)

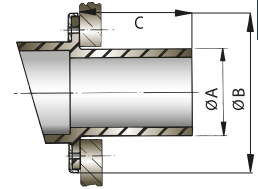

Type TRCPV / TRCSV

Type TRCPV has a synthetic body, Type TRCSV is made from stainless steel (AISI 316). Both types have an integral check valve. The exhaust hose can be fitted directly to these transom connectors.



TRCPV

Type	For exhaust hose (I.D.) inch (mm)	A = hole size Ø inch (mm)	Ø B inch (mm)	C inch (mm)
TRC40PV	1 ⁹ / ₁₆ (40)	2 ¹ / ₁₆ (52)	3 ¹ / ₂ (88)	2 ⁶¹ / ₆₄ (75)
TRC45PV	1 ³ / ₄ (45)	2 ¹ / ₁₆ (52)	3 ¹ / ₂ (88)	2 ⁶¹ / ₆₄ (75)
TRC50PV	2 (51)	2 ¹¹ / ₁₆ (68)	4 (104)	2 ⁶¹ / ₆₄ (75)
TRC60PV	2 ³ / ₈ (60)	2 ¹¹ / ₁₆ (68)	4 (104)	2 ⁶¹ / ₆₄ (75)
TRC75PV	3 (76)	3 ⁷ / ₈ (97)	5 ¹ / ₂ (140)	3 ⁴⁷ / ₆₄ (95)
TRC90PV	3 ¹ / ₂ (90)	3 ⁷ / ₈ (97)	5 ¹ / ₂ (140)	2 ⁶¹ / ₆₄ (75)

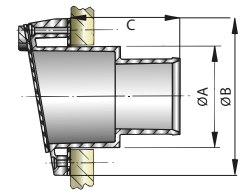

TRCSV

Type	For exhaust hose (I.D.) inch (mm)	A = hole size Ø inch (mm)	Ø B inch (mm)	C inch (mm)
TRC40SV	1 ⁹ / ₁₆ (40)	1 ⁵ / ₈ (41)	2 ²⁹ / ₃₂ (74)	2 ⁶¹ / ₆₄ (75)
TRC45SV	1 ³ / ₄ (45 m)	1 ¹³ / ₁₆ (46)	3 ¹ / ₈ (79)	2 ⁶¹ / ₆₄ (75)
TRC50SV	2 (51)	2 (51)	3 ⁵ / ₁₆ (84)	2 ⁶¹ / ₆₄ (75)
TRC60SV	2 ³ / ₈ (60)	2 ⁹ / ₁₆ (61)	3 ¹¹ / ₁₆ (94)	2 ⁶¹ / ₆₄ (75)
TRC75SV	3 (76)	3 ¹ / ₁₆ (77)	4 ⁵ / ₁₆ (110)	3 ³⁵ / ₆₄ (90)
TRC90SV	3 ¹ / ₂ (90)	3 ¹⁹ / ₃₂ (91)	14 ⁷ / ₈ (123)	4 ²¹ / ₆₄ (110)
TRC100SV	4 (102)	4 ¹ / ₁₆ (103)	5 ¹ / ₂ (140)	4 ¹⁷ / ₃₂ (115)
TRC125SV	5 (127)	5 ¹ / ₁₆ (128)	6 ⁵ / ₈ (169)	5 ¹ / ₂ (140)
TRC150SV	6 (152)	6 ¹ / ₃₂ (153)	7 ⁵ / ₈ (194)	5 ²⁹ / ₃₂ (150)

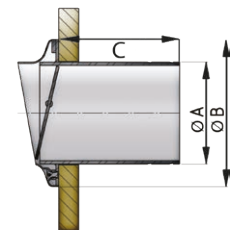

Type TC

Type TC is made from black glass reinforced synthetic with a decorative stainless steel (AISI 316) band. The exhaust hose can be fitted directly to this transom connector.



TC

Type	For exhaust hose (I.D.) inch (mm)	A = hole size Ø inch (mm)	Ø B inch (mm)	C inch (mm)
TC90	3 ¹ / ₂ (90)	3 ¹¹ / ₁₆ (93)	5 ⁹ / ₁₆ (141)	4 ²¹ / ₆₄ (110)
TC100	4 (102)	4 ¹ / ₁₆ (103)	6 ¹ / ₈ (155)	4 ¹⁷ / ₃₂ (115)
TC125	5 (127)	5 ¹ / ₁₆ (128)	7 (178)	5 ¹ / ₂ (140)
TC150	6 (152)	6 ¹ / ₃₂ (153)	8 (203)	5 ²⁹ / ₃₂ (150)

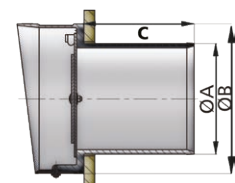

ACCESSORIES

Rubber exhaust hose type SLANG

Flexible and strong, saving valuable installation time

For a complete overview and available sizes see page 408.



SLANG

Silicone hose type SIHOSE

Extremely high temperature resistance

For a complete overview and available sizes see page 408.



SIHOSE

Synthetic hose connections

These hose connectors are made of synthetic material and are available in a straight, 60° or 90° bend type.

Type SLVBR

This is a straight type and suitable for hoses with an internal diameter of \varnothing 1 $\frac{1}{16}$ " to 5 $\frac{7}{8}$ " (40 to 150 mm).



SLVBR

Type	Type
SLVBR40K Straight \varnothing 1 $\frac{1}{16}$ " (40 mm)	SLVBR90K Straight \varnothing 3 $\frac{1}{2}$ " (90 mm)
SLVBR45K Straight \varnothing 1 $\frac{3}{4}$ " (45 mm)	SLVBR100K Straight \varnothing 4" (100 mm)
SLVBR50K Straight \varnothing 2" (51 mm)	SLVBR110K Straight \varnothing 4 $\frac{1}{16}$ " (110 mm)
SLVBR60K Straight \varnothing 2 $\frac{3}{8}$ " (60 mm)	SLVBR125K Straight \varnothing 5" (125 mm)
SLVBR65K Straight \varnothing 2 $\frac{9}{16}$ " (65 mm)	SLVBR150K Straight \varnothing 6" (150 mm)
SLVBR75K Straight \varnothing 3" (75 mm)	

Type SLVBG

This is a 60° bend type and suitable for hoses with an internal diameter of \varnothing 1 $\frac{1}{16}$ " to 5 $\frac{7}{8}$ " (40 to 150 mm).



SLVBG

Type	Type
SLVBG40K Bent 60° \varnothing 1 $\frac{1}{16}$ " (40 mm)	SLVBG90K Bent 60° \varnothing 3 $\frac{1}{2}$ " (90 mm)
SLVBG45K Bent 60° \varnothing 1 $\frac{3}{4}$ " (45 mm)	SLVBG100K Bent 60° \varnothing 4" (100 mm)
SLVBG50K Bent 60° \varnothing 2" (51 mm)	SLVBG110K Bent 60° \varnothing 4 $\frac{1}{16}$ " (110 mm)
SLVBG60K Bent 60° \varnothing 2 $\frac{3}{8}$ " (60 mm)	SLVBG125K Bent 60° \varnothing 5" (125 mm)
SLVBG65K Bent 60° \varnothing 2 $\frac{9}{16}$ " (65 mm)	SLVBG150K Bent 60° \varnothing 6" (150 mm)
SLVBG75K Bent 60° \varnothing 3" (75 mm)	

Type ELB

This is a 90° bend type and suitable for hoses with an internal diameter of \varnothing 5", 6", 8" or 10" (127, 152, 203 or 254 mm).



ELB

Type	Type
ELB90127 Bent 90° \varnothing 5" (127 mm)	ELB90203 Bent 90° \varnothing 8" (203 mm)
ELB90152 Bent 90° \varnothing 6" (152 mm)	ELB90254 Bent 90° \varnothing 10" (254 mm)

Flexible mountings for waterlocks

Minimise the noise

These flexible mountings can be used to minimise the noise caused by induced vibrations in the waterlock. Code is for a set of 4 mounts.

Type	
MGVIB45	Anti vibration mounts for MGP waterlocks up to 35 kg
MGVIB55	Anti vibration mounts for MGS, MGL and HPW waterlocks up to 143 lbs (65 kg)



MGVIB45

MGVIB55

Water mixer

In some boats the exhaust waterlock must be positioned so closely behind the engine's exhaust manifold (this is especially true in the case of near horizontal exhaust assemblies), that the injected cooling water does not always mix properly with the hot exhaust gases. This often results in the exhaust hose and/or the waterlock becoming overheated.

Installation of a water mixer directly behind the exhaust manifold will prevent this problem.

The water mixer is available for exhaust hoses with inside diameter of 3 $\frac{1}{2}$ ", 4", 5", 6" (90, 100, 125 or 150 mm).

Type	For exhaust hoses \varnothing inch (mm)	Type	For exhaust hoses \varnothing inch (mm)
MIXER090	3 $\frac{1}{2}$ (90)	MIXER125	5 (125)
MIXER100	4 (100)	MIXER150	6 (150)



MIXER



BOAT INSTRUMENTS

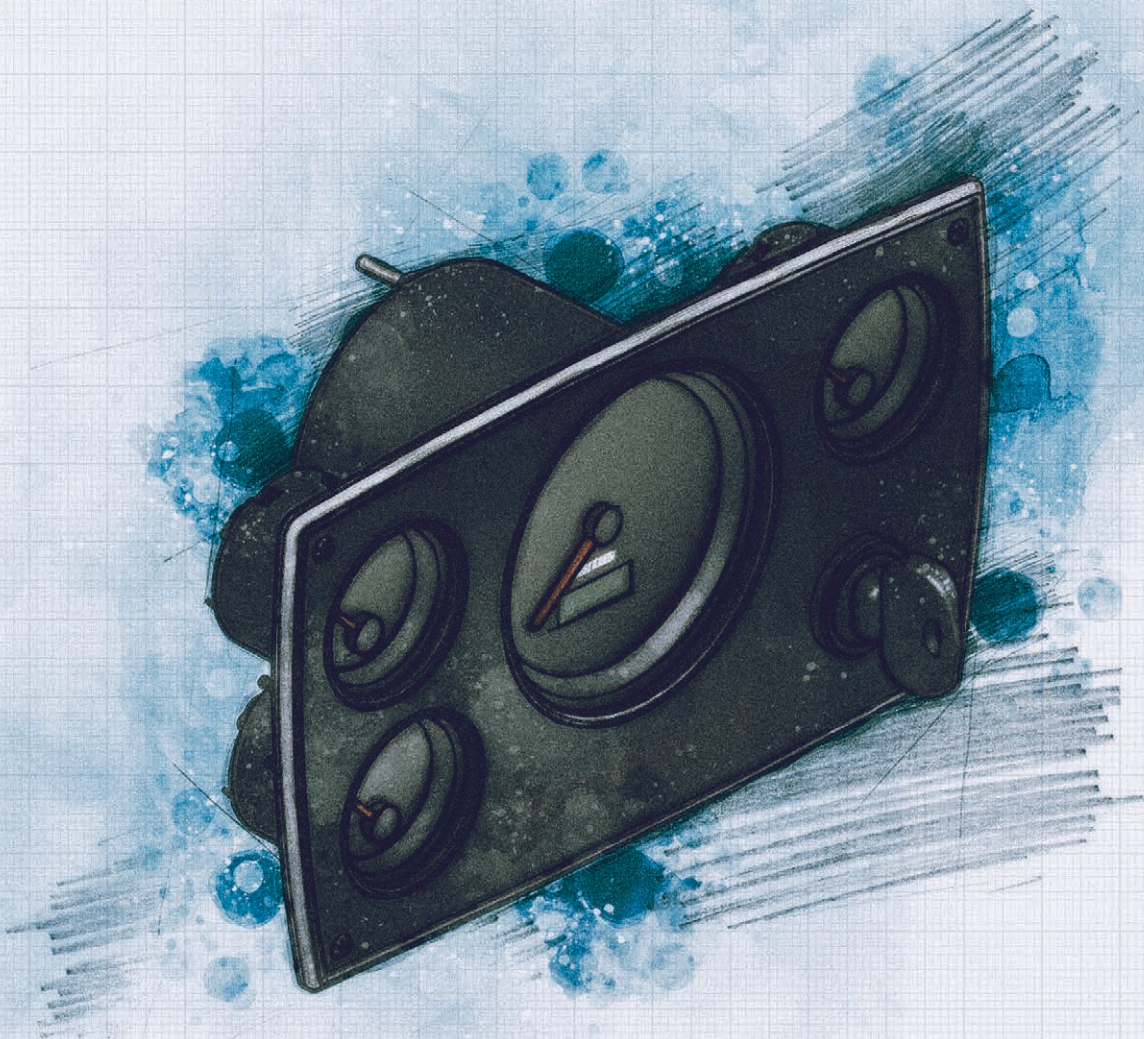



Overview VETUS boat instruments

Engine instrument panels see page 105



Dashboard gauges see page 108

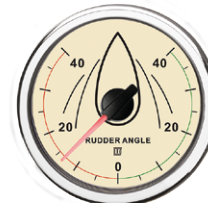

Energy consumption gauge see page 112



Tank senders / sensors see page 113



Switch panels see page 115



Detectors see page 117



WHY VETUS BOAT INSTRUMENTS?

VETUS offers a complete range of high quality panels and instruments for every vessel. New in our line-up are the V-CAN panels (for the new D-LINE and F-LINE engines). Just like our other switch panels, these CAN-bus panels come pre-wired for easy and correct installation. Existing VETUS instrument panels can easily be extended for total control of your boat. For an optimal overview of your vessel's (vital) functions, VETUS offers a complete revised range of double-glazed gauges.

All VETUS boat instruments meet the EMC requirements and are thoroughly tested by our R&D department, so we can guarantee smart looking panels and gauges that last.

Our range of boat instruments includes

- Engine instrument panels
- Bow and stern thruster control panels
- Switch panels
- Detectors and sensors
- Windscreen wiper control panels
- Gauges, sensors and wiring harnesses

Five good reasons to choose VETUS boat instruments

- 1. Highly accurate instrument and gauges**
Meticulously control and monitor every function of your vessel. Suitable for most vessels, as each instrument can be calibrated individually.
- 2. Reliable and durable products**
All panels and gauges are tested in-house, to guarantee highly reliable and long lasting products, even in the toughest environments. All instruments are double glazed to minimise condensation.
- 3. Good readability**
The translucent dials are backlit with bright dimmable and switchable bi-colour LEDs, offering high contrast, good readability and the ability to colour match your existing cockpit illumination.
- 4. OEM looks**
Gauges are supplied with two bezel: one in solid black and one in chrome coloured synthetic to match your existing interior.
- 5. Standardised dimensions**
VETUS panels and gauges are engineered to fit factory cut-outs for easy retrofit. The large instruments have an overall diameter of $\text{Ø } 4\frac{3}{64}$ " (114 mm) and fit a cut-out of $\text{Ø } 3\frac{15}{16}$ " (100 mm), while the small instruments have an overall diameter of $\text{Ø } 2\frac{31}{64}$ " (63 mm) and fit a cut-out of $\text{Ø } 2\frac{3}{64}$ " (52 mm). Both large and small instruments have a 10 mm height and will match your other gauges perfectly.



ENGINE INSTRUMENT PANELS

Type MPA

Stylish aluminium engine panels

Thanks to their stylish looks and quality materials, these new engine panels are an upgrade for your dashboard. The panels are made from marine grade anodized aluminium, which gives them and the individual gauges a classy look. The subtle curves and contours bring elegance and modernity to the helm station.

The MPA22 panel includes an ignition key, tachometer, hour meter, voltmeter and warning signals (LED and acoustic). The MPA34 panel also includes oil pressure and engine temperature gauges. Two additional gauges are an option with the extension panel MPA1XB (extra gauges should be ordered separately).

All panels can be ordered with black or white gauges. The panel is finished with a black weatherproof coating. Custom colours are available for order quantities of one hundred panels or more. Installed panels are IP64* splash proof and the electrical connections are backwards compatible with those of older VETUS panels.

Specifications

- Stylish design
- Made of marine grade anodized aluminium
- MPA2 and MPA3 include gauges, pre-heating starter switch with removable key and LED warning signals
Two extra gauges can be installed using the MPA1XB extension panel
- Easy installation. Supplied with gaskets and mounting screws
- IP64 splash proof
- Available with black or white gauges
- Available for 12 and 24 Volt systems

* The IP ratings quoted assume that the product is installed correctly and are from the front face only.



MPA22B



MPA34B



MPA1XB

Type	Description	Dial colour	RPM	Dimensions inches (mm)	Built in depth inches (mm)	Volt
MPA22KBS2	Aluminium engine panel	Black	0-4000	8 ³⁷ / ₆₄ x 6 ³ / ₁₆ (218 x 157)	4 ³ / ₄ (120)	12
MPA22KBW2	Aluminium engine panel	White	0-4000	8 ³⁷ / ₆₄ x 6 ³ / ₁₆ (218 x 157)	4 ³ / ₄ (120)	12
MPA22BS25	Aluminium engine panel	Black	0-5000	8 ³⁷ / ₆₄ x 6 ³ / ₁₆ (218 x 157)	4 ³ / ₄ (120)	12
MPA34BS2	Aluminium engine panel	Black	0-4000	10 ¹ / ₂ x 6 ³ / ₁₆ (267 x 157)	4 ³ / ₄ (120)	12
MPA34BW2	Aluminium engine panel	White	0-4000	10 ¹ / ₂ x 6 ³ / ₁₆ (267 x 157)	4 ³ / ₄ (120)	12
MPA34BS25	Aluminium engine panel	Black	0-5000	10 ¹ / ₂ x 6 ³ / ₁₆ (267 x 157)	4 ³ / ₄ (120)	12
MPA34BW25	Aluminium engine panel	White	0-5000	10 ¹ / ₂ x 6 ³ / ₁₆ (267 x 157)	4 ³ / ₄ (120)	12
MPA34BS4	Aluminium engine panel	Black	0-4000	10 ¹ / ₂ x 6 ³ / ₁₆ (267 x 157)	4 ³ / ₄ (120)	24
MPA34BW4	Aluminium engine panel	White	0-4000	10 ¹ / ₂ x 6 ³ / ₁₆ (267 x 157)	4 ³ / ₄ (120)	24
MPA34CANBS2	Aluminium engine panel CAN	Black	0-4000	10 ¹ / ₂ x 6 ³ / ₁₆ (267 x 157)	4 ³ / ₄ (120)	12
MPA34CANBS4	Aluminium engine panel CAN	Black	0-4000	10 ¹ / ₂ x 6 ³ / ₁₆ (267 x 157)	4 ³ / ₄ (120)	24
MPA1XB	Aluminium extension panel for two extra gauges	Black		6 ³ / ₁₆ x 3 ¹⁵ / ₁₆ (154 x 100)	3 ¹⁵ / ₁₆ (100)	

ENGINE INSTRUMENT PANELS

Type MP34B

This engine instrument panel is supplied with 6 monitoring lights, acoustic alarm, pre-heating/starter switch with removable key, combined revolution/hour counter, temperature gauge, voltmeter and oil pressure gauge. Waterproof according to IP64*.

Type	Dial colour	Rpm	Dimensions inches (mm)	Built-in depth inches (mm)	Volt
MP34BS12A	Black	0-4000	10 ¹ / ₁₆ x 6 ¹¹ / ₁₆ (255 x 161)	4 ³ / ₄ (121)	12
MP34BW12A	White	0-4000	10 ¹ / ₁₆ x 6 ¹¹ / ₁₆ (255 x 161)	4 ³ / ₄ (121)	12
MP34BN12A	Cream	0-4000	10 ¹ / ₁₆ x 6 ¹¹ / ₁₆ (255 x 161)	4 ³ / ₄ (121)	12
MP34BS15A	Black	0-5000	10 ¹ / ₁₆ x 6 ¹¹ / ₁₆ (255 x 161)	4 ³ / ₄ (121)	12
MP34BW15A	White	0-5000	10 ¹ / ₁₆ x 6 ¹¹ / ₁₆ (255 x 161)	4 ³ / ₄ (121)	12
MP34BN15A	Cream	0-5000	10 ¹ / ₁₆ x 6 ¹¹ / ₁₆ (255 x 161)	4 ³ / ₄ (121)	12
MP34BS24A	Black	0-4000	10 ¹ / ₁₆ x 6 ¹¹ / ₁₆ (255 x 161)	4 ³ / ₄ (121)	24
MP34BW24A	White	0-4000	10 ¹ / ₁₆ x 6 ¹¹ / ₁₆ (255 x 161)	4 ³ / ₄ (121)	24
MP34BN24A	Cream	0-4000	10 ¹ / ₁₆ x 6 ¹¹ / ₁₆ (255 x 161)	4 ³ / ₄ (121)	24



MP34B..



MP21B..

Type MP21B

This engine instrument panel is provided with 6 monitoring lights, combined revolution/hour counter, acoustic alarm and pre-heating/starter switch with removable key. An additional instrument can be fitted. This panel is suitable for installation on a fly-bridge or a second steering position. Waterproof according to IP64*.

Type	Dial colour	Dimensions inches (mm)	Built-in depth inches (mm)	Volt
MP21BS12A	Black	7 ⁵ / ₈ x 6 ¹¹ / ₁₆ (193 x 161)	4 ³ / ₄ (121)	12
MP21BN12A	Cream	7 ⁵ / ₈ x 6 ¹¹ / ₁₆ (193 x 161)	4 ³ / ₄ (121)	12

Extension panel

This panel is designed to receive 2 VETUS instruments with a cut-out diameter of Ø 2¹/₁₆" (52 mm). (Instruments to be ordered separately).

Type	Dial colour	Dimensions inches (mm)
XTPAN252A	Black	6 ¹ / ₁₆ x 3 ⁷ / ₈ (161 x 99)

XTPAN..



* The IP ratings quoted assume that the product is installed correctly and are from the front face only.

ENGINE INSTRUMENT PANELS

Type MP10B12

This engine instrument panel is designed for sailing boats. It has 5 monitoring lights, acoustic alarm and a pre-heating/starter switch with removable key. Waterproof according to IP64*.



MP10B12

Type	Dial colour	Dimensions inches (mm)	Built-in depth inches (mm)	Volt
MP10B12	Black	6 ¹ / ₈ x 3 ¹¹ / ₁₆ (156 x 94)	4 ³ / ₄ (120)	12

Type MP22B

This engine instrument panel is provided with 6 monitoring lights, combined revolution/hour counter, voltmeter, acoustic alarm and pre-heating/starter switch with removable key. Waterproof according to IP64*.

Type	Dial colour	RPM	Dimensions inches (mm)	Built-in depth inches (mm)	Volt
MP22BS12A	Black	0-4000	7 ⁵ / ₈ x 6 ¹¹ / ₁₆ (193 x 161)	4 ³ / ₄ (121)	12
MP22BW12A	White	0-4000	7 ⁵ / ₈ x 6 ¹¹ / ₁₆ (193 x 161)	4 ³ / ₄ (121)	12
MP22BN12A	Cream	0-4000	7 ⁵ / ₈ x 6 ¹¹ / ₁₆ (193 x 161)	4 ³ / ₄ (121)	12
MP22BS15A	Black	0-5000	7 ⁵ / ₈ x 6 ¹¹ / ₁₆ (193 x 161)	4 ³ / ₄ (121)	12
MP22BS24A	Black	0-4000	7 ⁵ / ₈ x 6 ¹¹ / ₁₆ (193 x 161)	4 ³ / ₄ (121)	24
MP22BW24A	White	0-4000	7 ⁵ / ₈ x 6 ¹¹ / ₁₆ (193 x 161)	4 ³ / ₄ (121)	24



MP22B..

* The IP ratings quoted assume that the product is installed correctly and are from the front face only.



All VETUS engine instrument panels on these pages come with a multi-pin connector as standard.

In order to reduce condensation as far as possible, all VETUS instrument gauges are double glazed.

All VETUS engine instrument panels featuring a key starter switch are supplied with a separate watertight cover for the switch.

ENGINE INSTRUMENT PANELS

Design your own panel with the "PWL" system

Many designers and installers wish to lay out their own instrument panel, rather than using a standard panel supplied by the engine manufacturer. This can be easily accomplished using the PWL system.

Advantages

- Choose your own instruments, black, cream or white and for 12 or 24 Volt supply
- All cables are bundled and colour coded: no more tracing loose wires
- Cable plugs and connectors are factory fitted, ready to connect to VETUS engine instruments
- The Instruments can be positioned up to 20" (50 cm) away from the key switch

Standard system

- Monitoring panel 5 1/8" x 1 3/8" (130 x 35 mm) with 6 warning lights
- Acoustic alarm
- Glow plug pre-heat and starting key switch
- Cable for tachometer (revolution counter/hour counter)
- Cables for voltmeter, oil pressure gauge, water temperature gauge
- Plugs for connection of extension cables

Optional equipment to complete the system

- Extension cable to the engine, available in 6.5 ft, 13 ft or 20 ft (2, 4 or 6 m)
- Cable splitter to connect to a second panel
- Revolution counter / hour counter
- Voltmeter, oil pressure gauge, water temperature gauge

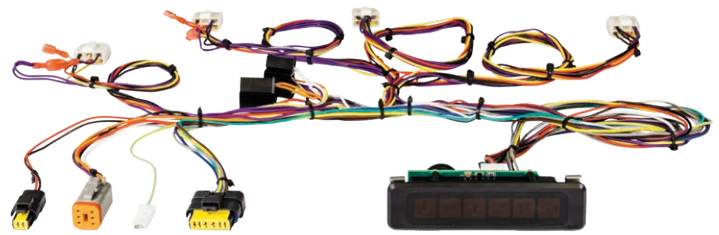

Type	
PWLK	Wiring loom for engine instruments, including warning light panel and starter switch, 12 / 24 Volt

DASHBOARD INSTRUMENTS WITH BLACK, CREAM OR WHITE DIALS

Dashboard instruments with black, cream or white dials

The range of VETUS gauges has been updated. The gauges are now dual voltage (12 V / 24 V naturally with the exception of the voltmeters) and come with two bezels: one solid black and one chrome effect plastic. Three reasons to choose VETUS boat instruments:

- High degree of accuracy: You can effortlessly monitor the vital functions of your boat, as VETUS gauges are thoroughly tested for accuracy. The tachometer is easily calibrated to suit your engine

- Reliability and longevity: High quality gauges that you can rely on for a very long time
- Smart illumination: Clear visibility in any condition, as the dials are backlit by dimmable LEDs for the best possible readability in bright sunshine or the darkest night. Switchable between yellow and red backlighting

In order to minimize clouding from condensation and subsequent water damage to internal components, all VETUS instruments have double glazed faces.

Gauges are available in three dial colours: code suffix 'W' for white, code suffix 'N' for cream and code suffix 'B' for the black facing. The large instruments have an overall diameter of Ø 4 1/2" (114 mm) and fit a cut-out of Ø 3 15/16" (100 mm), the small instruments have an overall diameter of Ø 2 1/2" (63 mm) and fit a cut-out of Ø 2 1/16" (52 mm). The height above the dashboard surface is 10 mm for both small and large gauges.



Code suffix: B = black, N = cream and W = white

Tachometer (revolution counter)

Available in Ø 4 1/2" (114 mm) diameter as 0-4000 r.p.m. version (for most diesel engines) or as 0-5000 r.p.m. version (to suit high speed engines). Suitable for both 12 V and 24 V and with incorporated digital hour counter.

Type	Colour	Volt	Cut-out size Ø inches (mm)	Overall diameter inches (mm)
TACHB4000	Black	12/24	3 15/16 (100)	4 1/2 (114)
TACHW4000	White	12/24	3 15/16 (100)	4 1/2 (114)
TACHN4000	Cream	12/24	3 15/16 (100)	4 1/2 (114)
TACHB5000	Black	12/24	3 15/16 (100)	4 1/2 (114)
TACHW5000	White	12/24	3 15/16 (100)	4 1/2 (114)
TACHN5000	Cream	12/24	3 15/16 (100)	4 1/2 (114)

TACH



DASHBOARD INSTRUMENTS WITH BLACK, CREAM OR WHITE DIALS

Exhaust/gas temperature alarm

Available in 2 1/2" (63 mm) diameter. Designed for water injected exhaust systems. Provides a visual and an audible alarm when the temperature inside the exhaust hose or the waterlock exceeds an acceptable level. A temperature sensor, to be fitted into the exhaust hose or the waterlock must be ordered separately. In the case of a twin engine installation two sensors may be connected to one alarm unit if required. One sensor will also operate two alarm units, in the case of a second steering position.



XHI

Type	Colour	Volt	Overall diameter Ø inches (mm)	Type	Colour	Volt	Overall diameter Ø inches (mm)
XHI12B	Black	12	2 1/2 (63)	XHI12W	Cream	12	2 1/2 (63)
XHI24B	Black	24	2 1/2 (63)	XHI24W	Cream	24	2 1/2 (63)

Trim gauge

Available in 2 1/2" (63 mm) diameter. For connection to the trim sensor of a stern drive or a set of trim tabs. Sensor resistance range: Trim down: 10 Ohm. Trim up: 180 Ohm. Suitable for both 12 V and 24 V.



TRIM

Type	Colour	Volt	Overall diameter Ø inches (mm)
TRIMB	Black	12/24	2 1/2 (63)
TRIMN	Cream	12/24	2 1/2 (63)
TRIMW	White	12/24	2 1/2 (63)
TRIMWR	Connection cable		

Temperature gauge

Available in 2 1/2" (63 mm) diameter. Scale calibration: 40-120°C. and 105-250°F. Temperature sensors are available as optional equipment. Suitable for both 12 V and 24 V.



TEMP

Type	Colour	Volt	Cut-out size Ø inches (mm)	Overall diameter Ø inches (mm)
TEMPB	Black	12/24	2 3/64 (52)	2 1/2 (63)
TEMPN	Cream	12/24	2 3/64 (52)	2 1/2 (63)
TEMPW	White	24/24	2 3/64 (52)	2 1/2 (63)
TEMPS	Sender for temperature gauge, 12/24V, single pole M14 x 1.5			
TEMPS2	Sender for temperature gauge, 12/24V, double pole M14 x 1.5			

Hour counter

Available in 2 1/2" (63 mm) diameter. Analogue engine hour counter which connects to the ignition switch. Suitable for both 12 V and 24 V.



HOUR

Type	Colour	Volt	Cut-out size Ø inches (mm)	Overall diameter Ø inches (mm)
HOURCB	Black	12/24	2 3/64 (52)	2 1/2 (63)
HOURCN	Cream	12/24	2 3/64 (52)	2 1/2 (63)
HOURCW	White	12/24	2 3/64 (52)	2 1/2 (63)

DASHBOARD INSTRUMENTS WITH BLACK, CREAM OR WHITE DIALS

Voltmeter

Available in 2 1/2" (63 mm) diameter. Can be supplied for 12 or 24 Volt D.C., with scale calibration respectively: 8 -16 Volt and 16 - 32 Volt.

Type	Colour	Volt	Cut-out size Ø inches (mm)	Overall diameter Ø inches (mm)
VLT12B	Black	12	2 3/64 (52)	2 1/2 (63)
VLT24B	Black	24	2 3/64 (52)	2 1/2 (63)
VLT12N	Cream	12	2 3/64 (52)	2 1/2 (63)
VLT24N	Cream	24	2 3/64 (52)	2 1/2 (63)
VLT12W	White	12	2 3/64 (52)	2 1/2 (63)
VLT24W	White	24	2 3/64 (52)	2 1/2 (63)



VLT

Ampmeter

Available in 2 1/2" (63 mm) diameter. Scale calibration: +/- 50 A, 80 A or 150A. Suitable for both 12 V and 24 V.

Type	Colour	Volt	Scale calibration	Cut-out size Ø inches (mm)	Overall diameter Ø inches (mm)
AMP050B	Black	12/24	+/- 50A	2 3/64 (52)	2 1/2 (63)
AMP050N	Cream	12/24	+/- 50A	2 3/64 (52)	2 1/2 (63)
AMP050W	White	12/24	+/- 50A	2 3/64 (52)	2 1/2 (63)
AMP080B	Black	12/24	+/- 80A	2 3/64 (52)	2 1/2 (63)
AMP080N	Cream	12/24	+/- 80A	2 3/64 (52)	2 1/2 (63)
AMP080W	White	12/24	+/- 80A	2 3/64 (52)	2 1/2 (63)
AMP150B	Black	12/24	+/- 150A	2 3/64 (52)	2 1/2 (63)
AMP150N	Cream	12/24	+/- 150A	2 3/64 (52)	2 1/2 (63)
AMP150W	White	12/24	+/- 150A	2 3/64 (52)	2 1/2 (63)



AMP

Black or grey waste water gauge

Available in 2 1/2" (63 mm) diameter. The waste water indicator can be provided with an interface (code EP412326). A warning light can be connected to this interface, which will indicate when the holding tank is almost full. Suitable for both 12 V and 24 V.

Type	Colour	Volt	Cut-out size Ø inches (mm)	Overall diameter Ø inches (mm)
WASTB	Black	12/24	2 3/64 (52)	2 1/2 (63)
WASTN	Cream	12/24	2 3/64 (52)	2 1/2 (63)
WASTW	White	12/24	2 3/64 (52)	2 1/2 (63)



WAST

Oil pressure gauge

Available in 2 1/2" (63 mm) diameter. Scale calibration 0-8 kg/cm² and 0-110 p.s.i. Oil pressure sensors are available as optional equipment. Suitable for both 12 V and 24 V.

Type	Colour	Volt	Cut-out size Ø inches (mm)	Overall diameter Ø inches (mm)
OILB	Black	12/24	2 3/64 (52)	2 1/2 (63)
OILN	Cream	12/24	2 3/64 (52)	2 1/2 (63)
OILW	White	12/24	2 3/64 (52)	2 1/2 (63)
OILS	Oil pressure sender 12/24V, single pole, M10 x 1K			
OILS2	Oil pressure sender 12/24V, double pole, M10 x 1K			



OIL

DASHBOARD INSTRUMENTS WITH BLACK, CREAM OR WHITE DIALS

Fuel gauge

Available in 2 1/2" (63 mm) diameter. Suitable for both 12 V and 24 V.

Type	Colour	Volt	Cut-out size Ø inches (mm)	Overall diameter Ø inches (mm)
FUELB	Black	12/24	2 3/64 (52)	2 1/2 (63)
FUELN	Cream	12/24	2 3/64 (52)	2 1/2 (63)
FUELW	White	12/24	2 3/64 (52)	2 1/2 (63)



FUEL

Fresh water gauge

Available in 2 1/2" (63 mm) diameter. Suitable for both 12 V and 24 V.

Type	Colour	Volt	Cut-out size Ø inches (mm)	Overall diameter Ø inches (mm)
WATERB	Black	12/24	2 3/64 (52)	2 1/2 (63)
WATERN	Cream	12/24	2 3/64 (52)	2 1/2 (63)
WATERW	White	12/24	2 3/64 (52)	2 1/2 (63)



WATER

Rudder indicator

To fit a cut out of 2 3/64" (52 mm) (RUDD.) or Ø 4 7/32" (107 mm) (RUDD.40). Suitable for 12 V and 24 V.

Type	Colour	Volt	Cut-out size Ø inches (mm)
RUddb	Black	12/24	2 3/64 (52)
RUDDN	Cream	12/24	2 3/64 (52)
RUDDW	White	12/24	2 3/64 (52)



RUDD

Type	Colour	Volt	Cut-out size Ø inches (mm)
RUddb40	Black	12/24	4 7/32 (107)
RUDDN40	Cream	12/24	4 7/32 (107)
RUDDW40	White	12/24	4 7/32 (107)

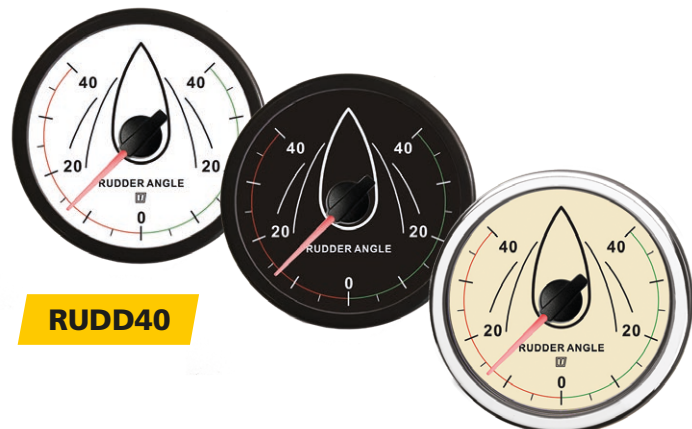

RUDD40



DASHBOARD INSTRUMENTS

Rudder position sending unit

Type RUDDS is required for indicators 2³/₆₄" (52 mm) (RUDD.) and Ø 4⁷/₃₂" (107 mm) (RUDD.40) and should be ordered separately.

Type	Description
RUDDS	Rudder position KUS

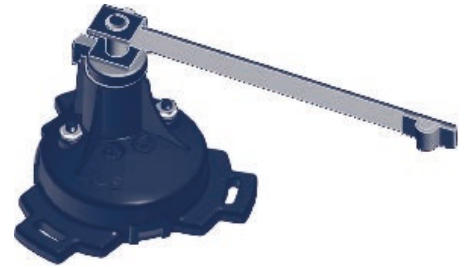

RUDDS

ENERGY CONSUMPTION GAUGE / BATTERY MONITOR

Type BATMONB

Knowing the exact state of charge

The monitor shows you the exact state of charge of a battery or battery bank. The BATMONB has several functions such as voltage, charge or discharge current, scale range of the nominal battery capacity and the time to complete discharge at the present discharge rate.

Specifications

- Suitable for 12 and 24 Volt electrical systems
- Hole diameter Ø 3¹¹/₃₂" (85 mm), overall diameter Ø 3¹³/₁₆" (97 mm)
- Supplied with a 200 A shunt and black and white bezels

Type	Description
BATMONB	Energy consumption gauge



BATMONB

TANK SENDERS / SENSORS

Universal sender for drinking water, petrol/gasoline and diesel fuel

Universal tank sender for drinking water, petrol and diesel fuel (type SENSOR). Available in 7 different lengths: 11", 12³⁹/₆₄", 15", 18⁵⁷/₆₄", 22²⁷/₃₂", 26³/₄" or 30⁴⁵/₆₄" (280, 320, 380, 480, 580, 680 or 780 mm). The VETUS universal tank sender indicates the difference in fluid level in steps of 2.5 inch (cm). Just compare this with other systems which can only show 3 positions (full - about half full - empty).

Type	Length inches (mm)	Volt
SENSOR280	11 (280)	12/24
SENSOR320	12 ³⁹ / ₆₄ (320)	12/24
SENSOR380	15 (380)	12/24
SENSOR480	18 ⁵⁷ / ₆₄ (480)	12/24
SENSOR580	22 ²⁷ / ₃₂ (580)	12/24
SENSOR680	26 ³ / ₄ (680)	12/24
SENSOR780	30 ⁴⁵ / ₆₄ (780)	12/24



SENSOR

Each tube length contains the maximum number of reed contacts (electronic switches), instead of the bare minimum of just three (full, half full, empty). Because of this, your tank gauges will read with maximum accuracy. The reed contacts are sealed "fluid-tight".

TANK SENDERS / SENSORS

Sender for waste water tanks

The arm length is adjustable between 7^{7/8}" and 16^{7/32}" (200 and 412 mm).

Specifications

- Empty 300 Ω
- Full 0 Ω
- For 12 and 24 Volt

Type	Description	Volt
WWSENSORA	Waste water sensor	12/24

WWSENSORA



Sender for fuel tanks

Sender for all rigid petrol and diesel fuel tanks with a depth between 5^{1/2}" and 26" (140 and 660 mm). Both the vertical strip and the horizontal float arm are completely adjustable.

Specifications

- Empty 280 Ω
- Full 40 Ω
- For 12 and 24 Volt

Type	Description	Volt
FSENSOR	Fuel tank float	12/24

FSENSOR

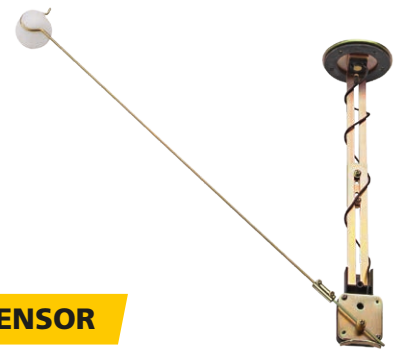

All VETUS level gauges are matched with our tank senders and can be connected directly to each other to give an accurate reading. To connect non-VETUS level indicators to a VETUS tank sender, it is necessary to install an EP46849 signal converter in the circuit.

Ultrasonic level sensors

The ultrasonic level sensors, SENSORA and SENSORB are contactless and will measure the fluid level in any shape of tank. They are suitable for use with: petrol, diesel fuel, drinking water, black and grey waste water. After installation, the sensor can be calibrated very easily with the aid of a LED and a calibration wire; no other equipment is required. The sensor may be installed in any shape of tank, regardless of its dimensions, but with a maximum depth of 3.9 ft. (120 cm). Max. tank capacity 1320 gallon (5000 litre). Model SENSORA may be connected to all standard VETUS analogue level indicators and also to the VETUS waste water control panel (WWCP). Model SENSORB has a CANbus output and may be connected to the VETUS ultrasonic level display SENSORD. SENSORA and SENSORB are **not** recommended for use with metal tanks.

Specifications SENSORA

- Voltage: 12 and 24 Volt D.C.
- Current consumption: 35 mA
- Interface: Analogue
- Tank depth: 3.9 ft. (120 cm)
- Accuracy : + / - 5%
- Temperature range: -4 to 158°F (20 to + 70°C)
- Flange: SAE, 5 holes
- Dimensions: Ø 3^{1/32}" x 2^{9/32}" (77 x 23 mm)



SENSORA

Specifications SENSORB

- Voltage: 12 and 24 Volt D.C.
- Current consumption: 35 mA
- Interface: Bus (RS485 bus)
- Tank depth: 3.9 ft. (120 cm)
- Accuracy : + / - 5%
- Temperature range: -4 to 158°F (- 20 to + 70°C)
- Flange: SAE, 5 holes
- Dimensions: Ø 3^{1/32}" x 2^{9/32}" (77 x 23 mm)



SENSORB

Type	Description
SENSORA	Ultrasonic level sensor 12/24V, for analogue indication of water, fuel and waste levels
SENSORB	Ultrasonic level sensor 12/24V, for indication via bus system of water, fuel and waste levels



INSTRUMENTS

Ultrasonic level system-bus version (RS485-bus) and graphic display

The VETUS ultrasonic level sensor, type SENSORB is contactless and will measure the fluid level in any shape of tank (metal tanks are not recommended), regardless of its dimensions, but with a maximum depth of 3.9 ft. (120 cm). It is suitable for use with: petrol, diesel fuel, drinking water, black and grey waste water. After installing the SENSORB it can be calibrated very easily using the SENSORD graphic display.

The graphic display instrument model SENSORD can be used to show the contents of up to 4 different tanks on one screen. A maximum of 8 tanks can be monitored with this system.

Specifications

- Power supply: 8 - 32 Volt D.C.
- Current consumption
 - Instrument: 125 mA at 12 Volt 63 mA at 24 Volt
 - Including background lighting
- Current consumption sensor: 35mA
- Communication protocol sensor: RS-485
- Number of sensors: max. 8
- Number of display instruments: max. 2
- Alarm outputs: 4
- Max. current on alarm output: 200 mA
- Languages: Dutch, English, German, French, Spanish and Italian
- Operating temperature: 32 to 122 °F (0 to +50 °C)
- Protection class: IP66

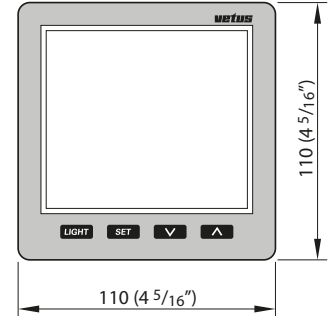

EMC-directive 89/336/EEC, 92/31/EEC and 93/68/EEC

The tank management system consists of a display instrument (SENSORD) and an ultrasonic level sensor (SENSORB) for each tank. The required number of sensors must be purchased separately.

Scope of supply SENSORD

- One display instrument
- One 8-pin female socket
- One UTP network cable (5 metres)
- One UTP splitter
- Gasket
- Mounting screws
- Drill template

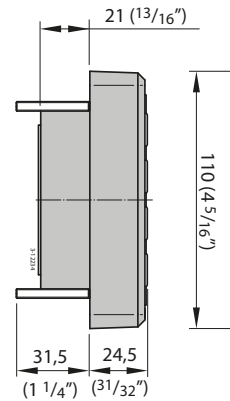

Type	Description
SENSORD	Display for level indication via bus-system, max 4 tanks



SENSORD

SWITCH PANELS

Type P8F

This panel is splash proof according to IP 64. It has 8 separate circuits, each provided with a switch, indicator LED and fuse holder and it is suitable for both 12 and 24 Volt D.C. circuits.

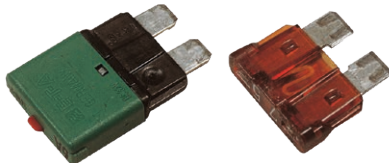

The panel can be used with conventional automotive (ATO) fuses or with automatic fuses.

The following automotive (ATO) fuses are supplied as standard:

2 x 1A, 2 x 3A, 4 x 5A, 2 x 7.5A, 4 x 10A and 2 x 15A. Automatic fuses may be ordered as optional equipment (see price list).

The 8 fuse holders are located in a separate compartment, which can be opened at the front of the panel and either type of fuse may be fitted. Sixty self-adhesive name/symbol plates for different functions are supplied. There are also 2 covers supplied for the fuse compartment, depending on whether automatic fuses or conventional automotive (ATO) fuses are used.

The panel is completely pre-wired and provided with a terminal rail, for connection of the power supply and the consumer equipment. The panel is made of synthetic and non-corrosive materials.

Specifications

- Dimensions 3⁵⁷/₆₄" x 6¹¹/₃₂" (99 x 161 mm)
- Built-in depth 1³/₄" (45 mm)

Type	Specifications
FUSE06A4	Automatic fuse 6 Amps, for P8FA Set of 4 pcs.
FUSE08A4	Automatic fuse 8 Amps, for P8FA Set of 4 pcs.
FUSE10A4	Automatic fuse 10 Amps, for P8FA Set of 4 pcs.
FUSE15A4	Automatic fuse 15 Amps, for P8FA Set of 4 pcs.
P8FA	Switch panel 12/24 Volt, for 8 blade fuses or automatic fuses (16 blade fuses supplied)



With automatic fuses.

P8FA



With conventional automotive (ATO) fuses.



SWITCH PANELS

Type P6

This panel features 6 on/off switches, 6 monitoring L.E.D.'s and a choice of either 6 automatic fuses, or 6 tubular glass fuses of 10 A.

Specifications

- Dimensions 3¹¹/₁₆" x 6⁹/₆₄" (94 x 156 mm)
- Built-in depth 2" (50 mm)

Available for 12 or 24 Volt D.C. circuits. Sixty self-adhesive name/symbol plates for different functions are supplied.

Type	Specifications	Volt
P6F12	Switch panel type P6 with 6 fuses	12
P6F24	Switch panel type P6 with 6 fuses	24
P12F12	Switch panel type P12 with 12 fuses	12
P12F24	Switch panel type P12 with 12 fuses	24
P6CB12	Switch panel type P6 with 6 circuit breakers	12
P6CB24	Switch panel type P6 with 6 circuit breakers	24
P12CB12	Switch panel type P12 with 12 circuit breakers	12
P12CB24	Switch panel type P12 with 12 circuit breakers	24



P6CB12

P6CB24

Automatic fuses



P6F12

P6F24

Tubular glass fuses

Type P12

This panel features 12 on/off switches, 12 monitoring L.E.D.'s and a choice of either 12 automatic fuses or 12 tubular glass fuses of 10 A.

Specifications

- Dimensions 7¹³/₃₂" x 6⁹/₆₄" (188 x 156 mm)
- Built-in depth 2" (50 mm)

Available for 12 or 24 Volt D.C. circuits. Sixty self-adhesive name/symbol plates for different functions are supplied.



P12F12

P12F24

Tubular glass fuses



P12CB12

P12CB24

Automatic fuses

VETUS switch panels are supplied pre-wired. The only work required is to connect the positive and negative feeds of the various services (lights, pumps etc.). These panels are made of synthetic and non-corrosive materials, but are not waterproof.

DETECTORS



GD1000

GD1000 and PD1000

Specifications

- Voltage: 12 or 24 Volt D.C.
- Maximum relay contact ratings for extractor fan, gas solenoid valve and external alarm: 1 A for each function
- Control panel dimensions: 3^{11/32}" x 3^{11/32}" (85 x 85 mm)
- Built-in depth: 1^{9/16}" (40 mm)
- Sensor: 1^{3/8}" x 1" x 2^{7/16}" (35 x 26 x 62 mm) high

Type	Specifications
GD1000	Gas & carbon monoxide detector 12/24 Volt, incl. sensor
GSENSOR	Additional sensor for gas & carbon monoxide detector type GD1000

Gas detector GD1000 panel and sensor

The VETUS gas detector model GD1000 offers a gas detection system for a range of combustible gases including propane, butane, methane and hydrogen. In addition it will also detect poisonous carbon monoxide. A single sensor is supplied as standard, which can detect both flammable gases (such as bottled gas) and carbon monoxide. A second sensor can be fitted as an option, for gas detection in an alternative location. A push button will manually actuate a remote solenoid operated cooking gas supply valve, if this is installed in the system. If this solenoid valve is in the open position (or not fitted), the presence of gas is detected continuously. If the valve is closed, detection will take place intermittently. Please note, the valve itself is not supplied with the gas detector.

If the gas detector senses high concentrations of flammable gases and/or carbon monoxide, it will trigger an acoustic alarm and a LED on the control panel. Petrol fumes can trigger the alarm at extremely low concentrations, which makes this device less suitable for boats with a petrol engine(s). The "Mute" button will silence the alarm. The gas detector is provided with three switched connections rated at 1 Amp each. In the event of an alarm situation, these will actuate (if fitted), an extraction ventilator, an external alarm or horn and close a solenoid operated cooking gas supply valve. The extraction ventilator can also be operated manually by means of the "Fan" button. Should the supply voltage drop too low, an acoustic alarm will be triggered and the LED on the control panel will flash. A test function confirms the correct functioning of the gas sensor(s), as well as the three switched connections for the ventilator, external alarm and gas valve. A LED on the sensor indicates when it has reached its maximum life span and should be replaced.



PD1000

Gas detector PD1000 panel and sensor

Gas detector model PD1000 specifically detects petrol vapour to prevent the risk of explosion in the engine room, as well as poisonous carbon monoxide (CO).

This gas detector can be supplied with one or two sensors. Both detection functions are carried out simultaneously. All other functions are as described for model GD1000 shown above.

Gas detector PD1000 is suitable for both 12 and 24 Volt D.C. supply and its dimensions are identical to model GD1000.

Type	Specifications
PD1000	Petrol vapour & carbon monoxide detector 12/24 Volt, incl. sensor
PSENSOR	Extra sensor for petrol vapour detection

It is recommended that the possible presence of petrol vapour and carbon monoxide be checked on a permanent basis; even when the boat is not in use! Therefore, always keep the power supply to this gas detector switched on.



FIRE PORT

Fire port

The fire port permits a fire extinguisher to be discharged into the engine space, or any other enclosed area without opening the engine access hatch or panel.

Specifications

- Nozzle can be inserted through the port in complete safety
- Minimizes the amount of oxygen so the fire does not increase
- Made of UV and seawater resistant synthetic material
- Available with black flange

Dimensions

- Cut-out Ø 1 1/2" (38 mm)
- Outside Ø 3" (76 mm)



FIREPORTB

Type	Specifications
FIREPORTB	Fireport for engine compartment with black finishing ring

CONTROL PANELS FOR BOW AND STERN THRUSTERS

Below a brief overview of some of the control panels for bow and stern thrusters.

For more models and information see system group Manoeuvring (page 169).



BPPPA



BPPJA



BPJR



BPSR



BPAJ



BPAS

FUEL SYSTEMS

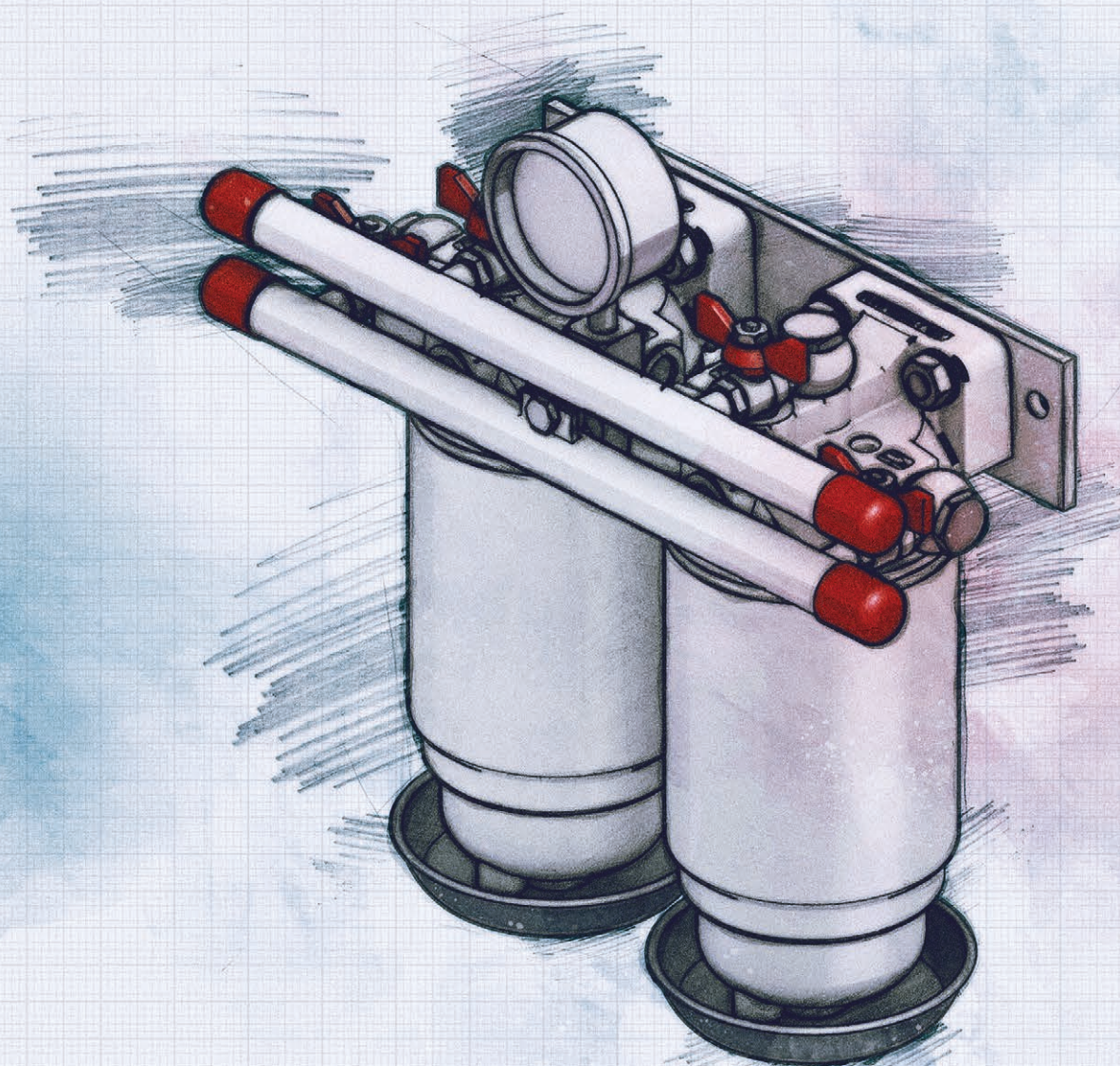

Overview VETUS fuel systems

Spin-on filters see page 123



Centrifugal filters see page 125



Fuel filter hose connectors

see page 126



Petrol/diesel filters see page 127



Petrol fuel filter see page 127



Splash stops see page 128



Tanks see page 129



Tank kits see page 131



No-smell filters see page 133



WHY VETUS FUEL SYSTEMS?

The fuel system on a boat is a VETUS specialty. You don't have to experience that helpless feeling when an engine unexpectedly stops at a critical moment. VETUS can provide you with the best products, accessories and tips to keep your engine running smoothly, ensuring your safety, comfort and compliance with good practise and environmental regulations.

A good working fuel system

Many people are unaware of the problems that water in fuel can cause. Even a small drop of water can be extremely damaging for the fuel pump, its injectors, filters and engine. Water carries dirt, rust and micro-organism through the narrow pipes into the system and when trapped, the water becomes a perfect breeding place, resulting in blockage in the fuel pump and additional wear and tear. Placing a fuel filter / water separator between the tank and the fuel lift pump will prevent damage to the engine and ensures easy starting and smooth running.

VETUS offers the following types of filters

Spin-on filters

With a maximum capacity from 50 to 121 gallons (190 to 460 litres) per hour, based on a patented fuel flow system in which water is separated from the fuel before the fuel flows back through the filter element.

Centrifugal filters

With a maximum capacity of 190 up to 951 gallons/hr (720 up to 3600 litres/hr). This modular system can be ordered in combinations of 2 to 6 filters for engines up to 5000 hp. The fuel inlet and outlet can be configured on the same or the opposite sides.

7 Reasons why you should choose a VETUS fuel system

- Our Splash Stop protects the environment by preventing fuel spillages
- Our fuel tanks are made from synthetic, corrosion free material resulting in less condensation
- Our fuel tanks are ready for installation, complete with a flange with bolt holes for gauge sender
- Our fuel filters have CE and ABYC approved clear bowl
- Our fuel filters have O-ring sealing for leak-free element replacement
- Our patented full-flow system gives VETUS fuel filters up to 5x larger filtering surface
- Our Fuel-safe provides complete low cost protection against fuel theft

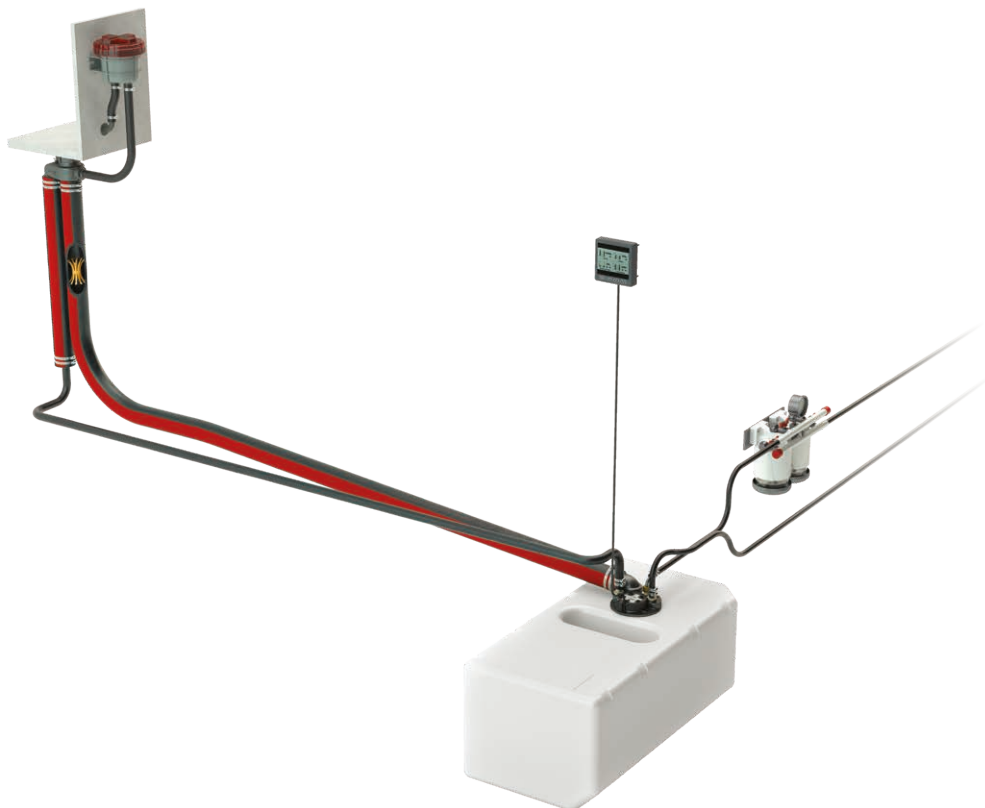

SPIN-ON FILTER

Patented fuel flow system

VETUS Spin-on fuel filters, with maximum capacities ranging from 50 to 121 gallons (190 to 460 litres) per hour, are based on a patented fuel flow system in which water and dirt is separated from the fuel before the fuel flows through the filter element. This way damage can be prevented and an easy starting, smooth running engine is guaranteed.

Note

All VETUS Spin-on filters meet the CE (ISO 10088) and ABYC requirements (relating to installation in the engine room) and have withstood a fire test of 2,5 minutes.

Type VTEB / VTEPB

Consistent filtering and a longer lifetime

These filters have an increased filtering surface and efficiency up to 5 times the surface of conventional filters. They are provided with a transparent bowl, which allows easy checking for water contamination. The elements can be easily replaced as a single unit, ruling out leakage or spills. The filters can be replaced without tools and with the engine running.

Characteristics

- Suitable for all diesel engines up to 600 hp
- A connection kit for $\frac{3}{8}$ " (10 mm) hose incl. 3 blind plugs is included
- All fittings feature O-ring sealing
- Single Spin-on filters are available with or without a manual pump to facilitate easy bleeding of the fuel system (type VTEPB)

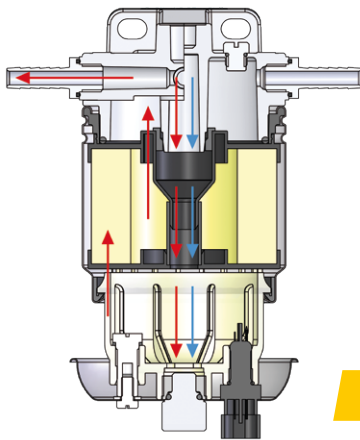

VTEB



VTEPB



75...VTEB

Double Spin-on filters

For boats that sail offshore

For boats that sail offshore, we strongly recommend these dual filter systems. In rougher sea conditions, dirt and water accumulated in the fuel tank becomes agitated and can rapidly clog the filter with little warning. This may result in loss of engine power and all the dangers that may present.

By turning the changeover valve, the system will switch over to a clean spare filter without having to turn off the engine. This dual filter system is supplied with a vacuum gauge which shows when the filter element should be replaced.



SPIN-ON FILTER

Product overview - Spin-on filters for diesel fuel

Single Spin-on filters
with or without bleed pump



Type		330VTEB	330VTEPB	340VTEB	340VTEPB	350VTEB	350VTEPB
Max. capacity in g/hr (l/hr)		42 (190)		84 (380)		102 (460)	
Version		single	with pump	single	with pump	single	with pump
Connections*		M16 x 1.5*		M16 x 1.5*		M16 x 1.5*	
Dimensions inches (mm)	Height	8 ⁵ / ₆₄ (205)		10 ⁷ / ₁₆ (265)		12 ⁵ / ₆₄ (325)	
	Width	4 ²³ / ₃₂ (120)		4 ²³ / ₃₂ (120)		4 ²³ / ₃₂ (120)	
	Depth	4 ²³ / ₃₂ (120)		4 ²³ / ₃₂ (120)		4 ²³ / ₃₂ (120)	
Weight lbs (kg)		2.9 (1.3)		3.2 (1.45)		3.5 (1.6)	
Replacement filter	10 µm (standard)	VT33EB		VT34EB		VT35EB	
	30 µm (optional)	VT33ER		VT34ER		VT35ER	
Replacement advice				Minimum annually			
Certification				CE and ABYC			



*A connection kit for 10mm hose and three blind plugs is standard supply.



Double Spin-on filters
Parallel or in line

Type		75330VTEB	75340VTEB	75350VTEB
Max. capacity in g/hr (l/hr)		42 (190)	84 (380)	102 (460)
When both filters are in use		84 (380)	168 (760)	204 (920)
Version		Double	Double	Double
Connections		R 1/2	R 1/2	R 1/2
Dimensions inches (mm)	Height	12 ¹ / ₆₄ (305)	14 ³ / ₈ (365)	16 ⁴⁷ / ₆₄ (425)
	Width	12 ¹³ / ₆₄ (310)	12 ¹³ / ₆₄ (310)	12 ¹³ / ₆₄ (310)
	Depth	6 ³⁷ / ₆₄ (167)	6 ³⁷ / ₆₄ (167)	6 ³⁷ / ₆₄ (167)
Weight lbs (kg)		10.4 (4,7)	11 (5)	11.7 (5,3)
Replacement filter	10 µm (standard)	2 x VT33EB	2 x VT34EB	2 x VT35EB
	30 µm (optional)	2 x VT33ER	2 x VT34ER	2 x VT35ER
Replacement advice		When vacuum gauge indicates between -2.8 and -5.4 psi, or annually		
Certification		CE and ABYC		

CENTRIFUGAL FILTERS

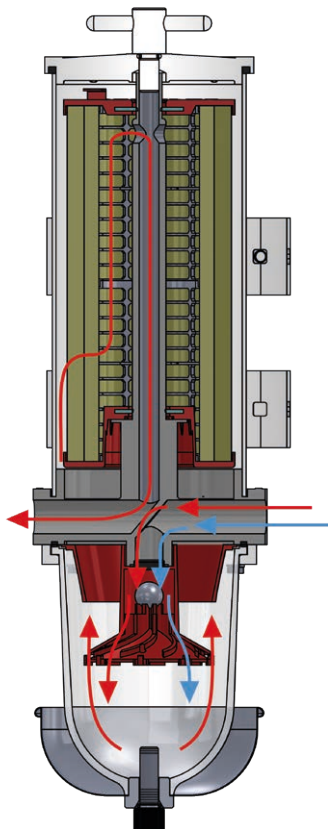

Modular system for effective filtering

VETUS centrifugal filters have maximum capacities ranging from 190 up to 951 gallons/hr (720 up to 3600 litres/hr). This modular system can be ordered in combinations of 2 to 6 filters for engines up to 5000 hp. The fuel in- and outlet can be configured on the same or the opposite sides. When determining the required capacity, it is always assumed that one filter is held in reserve. In case of a 6 filter configuration, 5 elements are in use and 1 is in reserve.

Note

All VETUS centrifugal filters meet the CE (ISO 10088) and ABYC and are Germanischer Lloyd certified which makes them applicable for commercial vessels.

Specifications

- Suitable for all diesel engines up to 5000 hp
- All fittings feature O-ring sealing
- Centrifugal filters are equipped with a vacuum gauge

Multiple centrifugal filters for diesel fuel

Available in parallel or in line

For the capacities, dimensions and specifications see table below.



..VTE



Type		75100VTE	79100VTE	83100VTE	87100VTE	91100VTE
Max. capacity in g/hr (l/hr)		160 (720)*	320 (1440)*	480 (2160)*	640 (2880)*	800 (3600)*
Version		2	3	4	5	6
Connections*		R 3/4	R 1	R 1 1/2	R 1 1/2	R 1 1/2
Dimensions inches (mm)	Height	21 ¹⁷ / ₆₄ (540)	21 ¹⁷ / ₆₄ (540)	21 ¹⁷ / ₆₄ (540)	21 ¹⁷ / ₆₄ (540)	21 ¹⁷ / ₆₄ (540)
	Width	18 ¹⁵ / ₁₆ (465)	24 ⁵¹ / ₆₄ (630)	31 ¹ / ₃₂ (788)	37 ¹ / ₆₄ (940)	43 ⁵ / ₁₆ (1100)
	Depth	13 ³ / ₁₆ (335)	13 ³ / ₁₆ (335)	13 ³ / ₁₆ (335)	13 ³ / ₁₆ (335)	13 ³ / ₁₆ (335)
Weight lbs (kg)		27.6 (12.5)	44 (20)	60.8 (27.6)	77 (35)	90.4 (41)
Replacement filter	30 µm (standard)	2 x 2020VTR	3 x 2020VTR	4x 2020VTR	5 x 2020VTR	6 x 2020VTR
	10 µm (optional)	2 x 2020VTB	3 x 2020VTB	4x 2020VTB	5 x 2020VTB	6 x 2020VTB

Replacement advice

When vacuum gauge indicates between -2.8 and -5.4 psi, or once a year

Certified

CE, ABYC and Germanischer Lloyd

* When determining the required capacity it is always assumed that one filter is held in reserve. When all filters are in use, 720 l/hr (160 g/hr) can be added to the capacity!



REPLACEMENT ELEMENTS FOR SPIN-ON AND CENTRIFUGAL FILTERS

VETUS recommends having a spare fuel filter at all times. This can be done by changing over filters in a multi-filter system or by keeping a spare element on board.

Spare Spin-on filter type VT3

Comes with a 10 micron element as standard. A spare part element with a filtration of 30 micron is also available (a filter of 10 micron will filter out more dirt and will also become clogged sooner). A 30 micron element is recommended when the tank is very large, infrequently filled or the fuel used is of low quality. Filtration of 10 micron has text printed in blue and 30 micron has text printed in red.

Replacement elements for spin-on filters

Type	Description	Filter	Max. g/hr (l/h)
VT33EB	Replacement fuel filter element	10 micron	50 (190)
VT34EB	Replacement fuel filter element	10 micron	100 (380)
VT35EB	Replacement fuel filter element	10 micron	121.5 (460)
VT33ER	Replacement fuel filter element	30 micron	50 (190)
VT34ER	Replacement fuel filter element	30 micron	100 (380)
VT35ER	Replacement fuel filter element	30 micron	121.5 (460)



VT3..

Spare element for centrifugal filter type 2020VT

Comes with a 30 micron element as standard. Also available in 10 micron.

Note

Filtration of 10 micron has an endcap in blue and 30 micron has an endcap in red. Just choose the product code ending with a R (red) or a B (blue) for the right spare part element.

This also holds true for older VETUS filters. These are still available and can be ordered using the code on the existing filter element that is being replaced.

Replacement elements for centrifugal filters

Type	Description	Filter	Max. g/hr (l/h)
2020VTB	Replacement fuel filter element	10 micron	190 (720)
2020VTR	Replacement fuel filter element	30 micron	190 (720)



2020VTR

Also available in blue (10 micron).

Fuel filter hose connectors

VETUS single 'Spin-on' fuel filters are supplied as standard with $\varnothing \frac{3}{8}$ " (10 mm) straight hose connectors. In some situations different connectors can be preferred. Therefore we offer $\varnothing \frac{3}{8}$ " (10 mm) connectors with a 90° bend, as well as straight and angled $\varnothing \frac{5}{16}$ " (8 mm) connectors.

The double 'Spin-on' filters feature a R1/2 male thread connection. For these filters both straight and angled connections of $\varnothing \frac{3}{16}$ " (8 mm) and $\frac{3}{8}$ " (10 mm) are available.

Type	Suitable for	Hose \varnothing inches (mm)	Model	Thread
FFS0800	Single spin-on filters type 330VTE(P)B, 340VTE(P)B and 350VTE(P)B	$\frac{5}{16}$ (8)	Straight	M16 x 1.5 male
FFS0890		$\frac{5}{16}$ (8)	90° Angled	M16 x 1.5 male
FFS1090		$\frac{3}{8}$ (10)	90° Angled	M16 x 1.5 male
FFS1300		$\frac{3}{8}$ (10)	Straight	M16 x 1.5 male
FFD0800	Double spin-on filters type 75330VTEB, 75340VTEB and 75350VTEB	$\frac{5}{16}$ (8)	Straight	G1/2 female
FFD0890		$\frac{5}{16}$ (8)	90° Angled	G1/2 female
FFD1000		$\frac{3}{8}$ (10)	Straight	G1/2 female
FFD1090		$\frac{3}{8}$ (10)	90° Angled	G1/2 female



FFS0890



FFD0890

FFD0800

PETROL/DIESEL FILTERS

Type WS

Filter for both petrol and diesel

Type WS180 and WS720 comply with the fire resistance test according to ISO 10088. These filters must be installed in a vertical position as close to the fuel tank as possible.

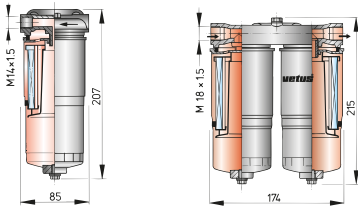

WS180



WS720

Type		WS180	WS720
Max. capacity in g/hr (l/hr)		40 (180)	160 (720)
Recommended capacity in g/hr (l/hr)		24 (110)	97 (440)
Connections	Thread	M14 x 1.5	M18 x 1.5
inches (mm)	Fittings	$\frac{5}{16}$ (8) hose barb	$\frac{9}{16}$ (15) compression fitting
Dimensions	Height	$8\frac{5}{32}$ (207)	$8\frac{15}{32}$ (215)
inches (mm)	Width	$3\frac{11}{32}$ (85)	$6\frac{17}{32}$ (174)
	Depth	$3\frac{11}{32}$ (85)	$3\frac{11}{32}$ (85)
Weight lbs (kg)		1.6 (0.7)	3.3 (1.5)
Replacement filter	40 μ m	WS180FE	2 x WS180FE
Replacement advice		After 200 service hours or annually	
Certification		Fire resistant ISO 10088	

Petrol fuel filter

Designed for use with outboard engines

Type 320VTNEB (Spin-on)

Type 320VTNEB is designed for use with outboard engines, but can also be used as a pre-filter for inboard engines. It fits petrol engines with a maximum of 500 hp.

Type		320VTNEB
Max. capacity in g/hr (l/hr)		26 (120)
Hose connections inches (mm)		$\frac{3}{8}$ (10)
Dimensions inches (mm)	Height	$6\frac{3}{16}$ (157)
	Width	$4\frac{3}{32}$ (104)
	Depth	$4\frac{13}{32}$ (112)
Weight lbs		1.3
Replacement filter	10 μ m	VTN32EB
Replacement advice		After 200 service hours or at least once a year
Certification		Fire resistant ISO 10088



320VTNEB



FUEL SPLASH-STOP

Overflowing fuel or foam collector

Type FSA

The fuel Splash-stop is connected right under the deck filler plate to ensure that overflowing fuel or foam cannot flood onto the deck. The excess diesel* or petrol fuel is collected in a parallel hose which functions as a reservoir, returning the fuel back into tank.

The capacity of the reservoir is determined by the length and diameter of the hose (see 3 types below). Always choose the largest reservoir possible, with a maximum of 0.58 gallons (2,2 litres). The housing and hose connection are made of anodized aluminium. The fill and vent lines, hose clamps and a matching stainless steel (AISI 316) deck entry should be ordered separately. The fuel Splash-Stop meets all the latest CE (ISO 10088) and ABYC standards.



FSA

FSA3816

• Suitable for \varnothing 1 1/2" (38 mm) hose and 5/8" (16 mm) breather line. The capacity of \varnothing 1 1/2" (38 mm) hose is 0.27 gal. (1,1 ltr) p/mtr

FSA5116

• Suitable for \varnothing 2" (51 mm) hose and 5/8" (16 mm) breather line. The capacity of \varnothing 2" (51 mm) hose is 0.49 gal. (2 ltr) p/mtr

FSA5119

• Suitable for \varnothing 2" (51 mm) hose and 3/4" (19 mm) breather line. The capacity of \varnothing 2" (51 mm) hose is 0.49 gal. (2 ltr) p/mtr

Type	L x W x H inches	Hose \varnothing inches (mm)	Breather \varnothing inches (mm)	Capacity gal.p/mtr (litr.)
FSA3816	5 ³ / ₄ X 3 ²⁵ / ₆₄ X 4 ⁴⁹ / ₆₄	1 1/2 (38)	5/8 (16)	0.27 (1,1)
FSA5116	5 ³ / ₄ X 3 ²⁵ / ₆₄ X 4 ⁴⁹ / ₆₄	2 (51)	5/8 (16)	0.49 (2)
FSA5119	5 ³ / ₄ X 3 ²⁵ / ₆₄ X 4 ⁴⁹ / ₆₄	2 (51)	3/4 (19)	0.49 (2)

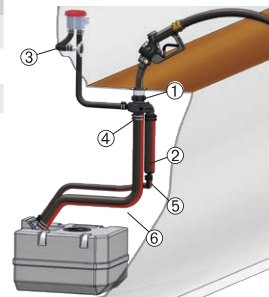

1. Deck entry
2. Reservoir / overflow hose and breather line
3. Tank breather line to outside
4. Splash-Stop
5. Hose connection
6. Fuel filling hose

* Note

A no-smell filter (for diesel only) can be fitted in the tank breather line to prevent unpleasant smells. If the filter is located well above the deck entry, the breather line may exit lower than the deck level if required. To prevent expensive fuel theft, we recommend placing a FUELSAFE (see page 134) into the Splash-Stop.

Type FS

FS3816

- Deck entry \varnothing 1 1/2" (38 mm)
- Filler hose connection \varnothing 1 1/2" / 2" (38 / 51 mm)
- Breather connection \varnothing 5/8" (16 mm)

FS5116

- Deck entry \varnothing 2" (51 mm)
- Filler hose connection \varnothing 1 1/2" / 2" (38 / 51 mm)
- Breather connection \varnothing 5/8" (16 mm)

FS5125

- Deck entry \varnothing 2" (51 mm)
- Filler hose connection \varnothing 2" (51 mm)
- Breather connection \varnothing 1" (25 mm)

Note

For use outside the engine room only!



FS

Type	L x W x H inches	Hose \varnothing inches (mm)	Breather inches (mm)	Deck entry \varnothing inches (mm)
FS3816	9 ²⁷ / ₃₂ X 4 ²³ / ₃₂ X 8 ¹⁵ / ₃₂	1 1/2 / 2 (38 / 51)	5/8 (16)	1 1/2 (38)
FS5116	9 ²⁷ / ₃₂ X 4 ²³ / ₃₂ X 8 ¹⁵ / ₃₂	1 1/2 / 2 (38 / 51)	5/8 (16)	2 (51)
FS5125	9 ²⁷ / ₃₂ X 4 ²³ / ₃₂ X 8 ¹⁵ / ₃₂	2 (51)	1 (25)	2 (51)

VETUS Splash-Stop model FS is directly connected to a deck entry plate (1), with a diameter of 1 1/2" (38 mm) or 2" (51 mm) (optional equipment).

It ensures that overflowing diesel fuel or foam will not come out of the deck entry - soiling your deck and polluting the water, but will be neatly caught inside the reservoir (with a capacity of approx. 2 litres). Excessive fuel will flow back into the main tank through connection (2).

This connection also serves as the necessary tank ventilation. The breather line to outside is to be installed to connection (3).

A VETUS diesel smell filter may be installed into this breather line as well. If the diesel smell filter is positioned well above the deck, the breather line may exit below the deck level, if so required. FS is supplied with connections for \varnothing 1 1/2" (38 mm) or for \varnothing 2" (51 mm) fuel filling hose (4).

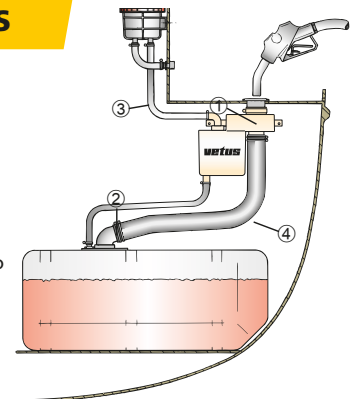

RIGID TANKS FOR DIESEL FUEL

Basic tank type ATANK

Multiple purposes - material ideal for waste water, drinking water and diesel

These tanks are made of thick walled high-grade polyethylene which is both rust free and less prone to condensation compared with metal tanks. Due to the seamless construction of the tanks, leakage is impossible. Fittings can be installed wherever you choose and can be ordered separately.

Tanks are supplied with diesel, fresh water and waste water labels.

Specifications

- Tanks are in accordance within the ISO 21487 standard when inspection lid ILT (see page 132) is installed and the supplied diesel sticker is used
- Available in 11, 16, 23, 29, 36, 44.7, 56.5, 88 and 103 gal. (42, 61, 88, 110, 137, 170, 215, 335 and 390 litres)
- Wall thickness 1/4" (7 mm)
- Colour Light blue translucent
- Suitable for diesel (up to 212°F (100°C))

For dimensions and types see details below.

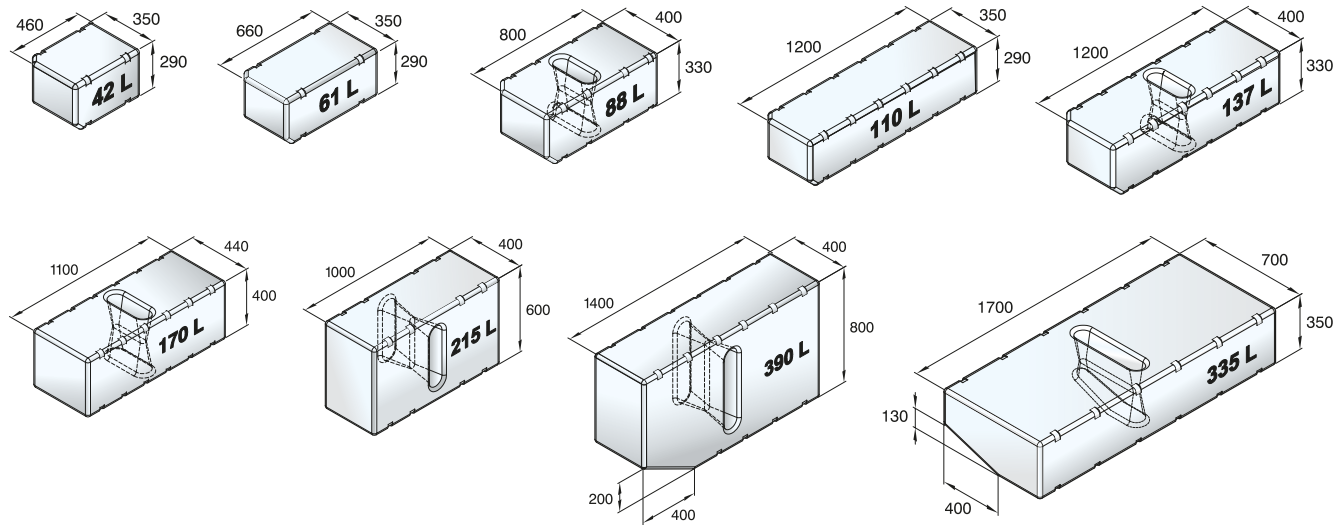

Dimensions: plus or minus 2%



ATANK

Type	Suitable for	Capacity
ATANK42	Diesel, drinking water and waste water	11 gal. (42 L)
ATANK61	Diesel, drinking water and waste water	16 gal. (61 L)
ATANK88 *	Diesel, drinking water and waste water	23 gal. (88 L)
ATANK110	Diesel, drinking water and waste water	29 gal. (110 L)
ATANK137 *	Diesel, drinking water and waste water	36 gal. (137 L)
ATANK170 *	Diesel, drinking water and waste water	44.7 gal. (170 L)
ATANK215 *	Diesel, drinking water and waste water	56.5 gal. (215 L)
ATANK335 *	Diesel, drinking water and waste water	88 gal. (335 L)
ATANK390 *	Diesel, drinking water and waste water	103 gal. (390 L)

*Provided with a baffle as a standard construction element



RIGID TANKS FOR DIESEL FUEL

Tank with connectors type FTANKA/B

Designed for diesel fuel

This range of rigid VETUS tanks is made of high-grade polyethylene. The centre point for a SAE flange gauge sender is incorporated (except FTANK25) together with 5 blind bolt holes. The gauge sender should be ordered separately. Tanks are in accordance with the ISO 21487 standard.

Each tank is supplied with the following connections

- Fixed hose connector \varnothing 1 1/2" (38 mm) (\varnothing 2" (51 mm) for FTANK25) for filling and 5/8" (16 mm) for breather line
- Rotating hose connector \varnothing 5/16" (8 mm) (type A + FTANK25) or 3/8" (10 mm) (type B) with pick-up pipe for suction
- Rotating hose connector \varnothing 5/16" (8 mm) (type A + FTANK25) or 3/8" (10 mm) (type B) for fuel-return



Type	Description	Capacity
FTANK25	Synthetic diesel fuel tank	6 gal. (25 L)
FTANK40A	Synthetic diesel fuel tank	10 gal. (40 L)
FTANK60A	Synthetic diesel fuel tank	15 gal. (60 L)
FTANK80A	Synthetic diesel fuel tank	21 gal. (80 L)
FTANK40B	Synthetic diesel fuel tank	10 gal. (40 L)
FTANK60B	Synthetic diesel fuel tank	15 gal. (60 L)
FTANK80B	Synthetic diesel fuel tank	21 gal. (80 L)

FTANK..A

FTANK..B

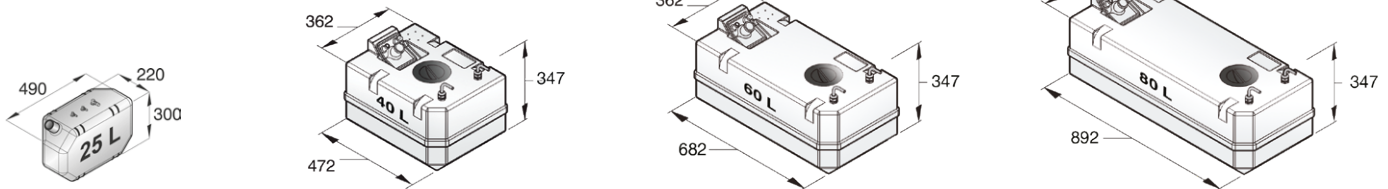

Dimensions: plus or minus 2%. Height dimensions includes connectors.

APT100 - One tank for all purposes

Fresh water, waste water or diesel: this tank can handle it

A new series of all-purpose tanks is introduced by VETUS: meet the APT100. Made from high-grade polyethylene, this large capacity tank handles almost any liquid you would like to store on your boat. It features an inspection lid and is ready for the appropriate ILT connection kit. On the bottom is a 1 1/2" (38 mm) connection that can be drilled out for interconnection purpose or draining. The robust appearance and the all-new design make this the tank to have.

Due to the large inspection hole (5 1/2" - 140 mm) the tank meets ISO 21487 when it comes to fuel directives. Depending on the purpose you have for this tank, an appropriate connection set is available from VETUS. The tank is easy to install and has enough capacity for longer boat trips.

Specifications

- All-purpose 100 litre tank, suitable for fresh water, waste water or diesel
- Made from high-grade polyethylene
- Large inspection port to meet ISO 21487 requirements
- 1 1/2" (38 mm) connection (to drill open) for interconnection purpose or draining
- ILT-concept ready



Typ	Tank capacity gallon (ltr)	Dimensions inches (mm)	Wall thickness inches (mm)	\varnothing Bottom connection inches (mm)
APT100	26.4 (100)	39 3/4 x 15 3/8 x 12 3/8 (1010 x 390 x 315)	5/16 (8)	1 1/2 (38)

APT100

CONNECTION KIT FOR RIGID TANKS

Type FTL....B

Saves considerable installation time

This connection kit has an anodized, salt water resistant aluminium lid with a counter flange and a rubber seal which is tightened very easily with just 3 bolts compressing the rubber seal to ensure a perfect seal. The set contains all the required connections, only 1 single hole with a diameter of $4\frac{3}{16}$ " (114 mm) needs to be cut in the top of the fuel tank. This connection kit is also suitable for plastic, metal or GRP diesel or petrol fuel tanks.



FTL38..B

FTL51..B

The following connections are supplied

- Hose connection for filling \varnothing 1 1/2" (38 mm) or 2" (51 mm) and a 5/8" (16 mm) tank ventilation connection
- Fuel suction pipe according to model selected
 - \varnothing 5/16" (8 mm), max. tank depth 440 mm
 - \varnothing 3/8" (10 mm), max. tank depth 850 mm
 - \varnothing 5/8" (16 mm), max. tank depth 970 mm
- Fuel return for \varnothing 5/16", 3/8" or 5/8" (8, 10 or 16 mm) hose
- Mounting flange for tank level sensors (connection is suitable for sensors with a 5-hole SAE flange)
- Terminal tag 1/4" (6,3 mm) for ground wire
- 2 Mounting straps to secure tank

Type	Filler inches (mm)	Supply/return \varnothing inches (mm)	Vent inches (mm)
FTL3808B	1 1/2 (38)	5/16 (8)	5/8 (16)
FTL3810B	1 1/2 (38)	3/8 (10)	5/8 (16)
FTL3815B	1 1/2 (38)	5/8 (16)	5/8 (16)

Type	Filler inches (mm)	Supply/return \varnothing inches (mm)	Vent inches (mm)
FTL5108B	2 (51)	5/16 (8)	5/8 (16)
FTL5110B	2 (51)	3/8 (10)	5/8 (16)
FTL5115B	2 (51)	5/8 (16)	5/8 (16)



CONNECTION KIT FOR RIGID TANKS

Type FTLDB

For installation of twin tanks

With this interconnection kit 2 VETUS fuel tanks can be connected. The lid of this set has 2 connections of 16 mm for tank ventilation. 2 Brass skin fitting (G3/4) and a coupling are supplied to connect the tanks. Including 2 mounting strips to secure the tank.

Type	Description
FTLDB	Connection kit for 2 fuel tanks



FTLDB

Universal inspection port for tanks type ILT120

Innovative inspection port with robust design

The standard delivery of the VETUS ILT is an innovative port with flange-in-ring design which facilitates easy opening, inspecting and cleaning the tank, even after being closed for a long time. The inspection port has a counter flange and a rubber seal which are inserted into a $\text{\O} 6\frac{1}{4}$ " (159 mm) hole in the tank. All that needs to be done is tighten the 4 supplied bolts which compresses the rubber seal to ensure perfect sealing.

The "clamp and seal" design simplifies installation, making the drilling of a $\text{\O} 6\frac{1}{4}$ " (159 mm) hole the hardest part in the installation!

The black blind plate can be replaced by various connection kits.

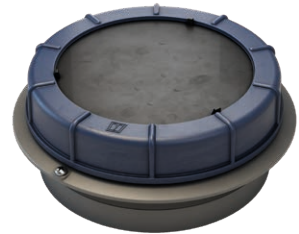

ILT120

Fuel connection kit type ILTCONF38

This fuel connection disc will take care of all fuel related connections

- $\text{\O} 1\frac{1}{2}$ " (38 mm) fuel fill connection
- $\text{\O} \frac{5}{16}$ " / $\frac{3}{8}$ " (8 / 10 mm) fuel suction connection
- $\text{\O} \frac{5}{16}$ " / $\frac{3}{8}$ " (8 / 10 mm) fuel return connection
- Ventilation connection $\text{\O} \frac{5}{8}$ " (16 mm)
- 5 hole SAE flange tank level sensor connection
- $\text{\O} \frac{5}{16}$ " (8 mm) suction connection for marine diesel heaters

Type	Description	Diameter inches (mm)	Diameter hole inches (mm)
ILT120	Inspection port with counter flange	4 $\frac{3}{4}$ " (120)	6 $\frac{1}{4}$ " (159)
VSAW159	$\text{\O} 6\frac{1}{4}$ " hole saw for plastic, G.R.P. or metal tanks		6 $\frac{1}{4}$ " (159)
ILTCONF38	Fuel connection kit		



ILTCONF38

NO-SMELL FILTERS

No-smell filters for diesel tanks type NSFD/S

Remedy for escaping diesel fuel odours

With these filters diesel fuel smells can no longer escape through the breather line which is required for all fuel tanks on boats. The no-smell filters are easy to install and contain activated carbon material to absorb odours. To avoid diesel fuel and froth entering the filter housing and its element, it is imperative to install in combination with a Splash-Stop (page 128). A VETUS no-smell filter should not be used for petrol tanks.

Specifications

- Model NSFD: l 5¹³/₁₆" x w 5¹⁵/₁₆" x h 6³/₈" (148 x 150 x 162 mm)
- Suitable for Ø 5/8", 3/4" or 1" (16, 19 or 25 mm) connectors
- Model NSFDS: l 4⁷/₃₂" x w 4⁹/₁₆" x h 4⁹/₁₆" (107 x 111 x 111 mm)
- Only suitable for Ø 5/8" (16 mm) breather hose

Please note

The filter element is replaceable. Replacement can be done with traditional carbon filters or with the improved solution: the dual function filter canister type NSFCAN. It should be renewed once a year.



NSF.D

NSF16DS

Type	Description	L x W x H inches (mm)	Hose Ø inches (mm)
NSF16D	Large no-smell filter	5 ¹³ / ₁₆ x 5 ¹⁵ / ₁₆ x 6 ³ / ₈ (148 x 150 x 162)	5/8 (16)
NSF19D	Large no-smell filter	5 ¹³ / ₁₆ x 5 ¹⁵ / ₁₆ x 6 ³ / ₈ (148 x 150 x 162)	3/4 (19)
NSF25D	Large no-smell filter	5 ¹³ / ₁₆ x 5 ¹⁵ / ₁₆ x 6 ³ / ₈ (148 x 150 x 162)	1 (25)
NSF16DS	Small no-smell filter	7 ⁷ / ₃₂ x 4 ⁹ / ₁₆ x 4 ⁹ / ₁₆ (107 x 111 x 111)	5/8 (16)
NSF16FES	Spare filter element for small no-smell filters		
NSF16FE	Spare filter element for large no-smell filters		

No-smell filters element type NSFCAN

Revolutionary dual function

Type NSFCAN is a pre-filled canister with a measured quantity of activated carbon and special gel granules. The combination of gel granules and carbon provides a perfect dual function. Traditional carbon filters often lose efficiency due to humidity and condensation. The gel granules in this filter absorb the moistures which cause the efficiency loss and also ensure significantly less air borne moisture allowed into the fuel tank.

Specifications

- Suitable for new and existing VETUS no-smell filters type NSFD
- Transparent cover so you can easily see when the special gel is saturated and replacement of the canister is necessary
- The filters reduce the risk of mould and 'diesel bug' in the tank (moisture in diesel fuel can be a perfect breeding ground for mould and bacteria)
- The smaller version type NSFCANS can be used with no-smell filter NSF16DS



NSFCAN

NSFCANS

Type	Description
NSFCAN	Dual function no-smell filter canister for type NSF filters
NSFCANS	Dual function no-smell filter canister for type NSF_S filters

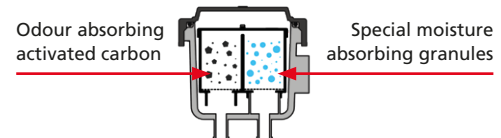

ACCESSORIES

Type VSAW

Type	Description
VSAW114	Ø 4 ³¹ / ₆₄ " (114 mm) hole saw for plastic, G.R.P. or stainless steel (AISI 316) tanks
VSAW159	Ø 6 ¹ / ₄ " (159 mm) hole saw for plastic, G.R.P. or metal tanks

VSAW114

VSAW159



FUELSAFE

No more fuel pumped out of the tank

Type FUELSAFE is made of petrol and diesel resistant synthetic material. No dismantling is required which makes installation of this safety device very simple. The plastic packaging sleeve can be used to insert the device.

Specifications

- Dimensions Ø 2¹¹/₆₄" x 2⁵³/₆₄" (55 x 72 mm)
- Suitable for hoses with internal diameters of Ø 1¹/₂" (38 mm) and 2" (51 mm)

Type	Description
FUELSAFE	Fuel theft security device



FUELSAFE

Fuel hose

For transportation of petrol and diesel fuels

Type FUHOSEA

The inside is made of NBR rubber and the outside is CR rubber. This hose can also be used as a ventilation line. Available as quality type A1, which means that these fuel hoses have been successfully subjected to a fire test for 2,5 minutes and have a maximum permeability of 100 grams/m²/ 24 hour.

Meets the CE standard: ISO 7840 marine fuel A1

For a complete overview of hoses see page 404.

FUHOSEA



Type FUHA115

Especially suitable for use with petrol because of its low permeability of 15 grams/m²/ 24 hour.

Meets the highest CE standard: ISO 7840 marine fuel A1-15

For a complete overview of hoses see page 404.

FUHA115



Fuel filling hose

Extremely flexible!

This type of hose, made of NBR rubber with spiralled steel inlay, is suitable for petrol and diesel fuels. Type FFHOSE meets requirements of SAE J 1527 and the standard ISO 7840 marine fuel A2 and is resistant to temperatures of - 22° and + 212°F (-30° and up to 100°C).

For a complete overview of hoses see page 404.

FFHOSE



FRESH WATER SYSTEMS

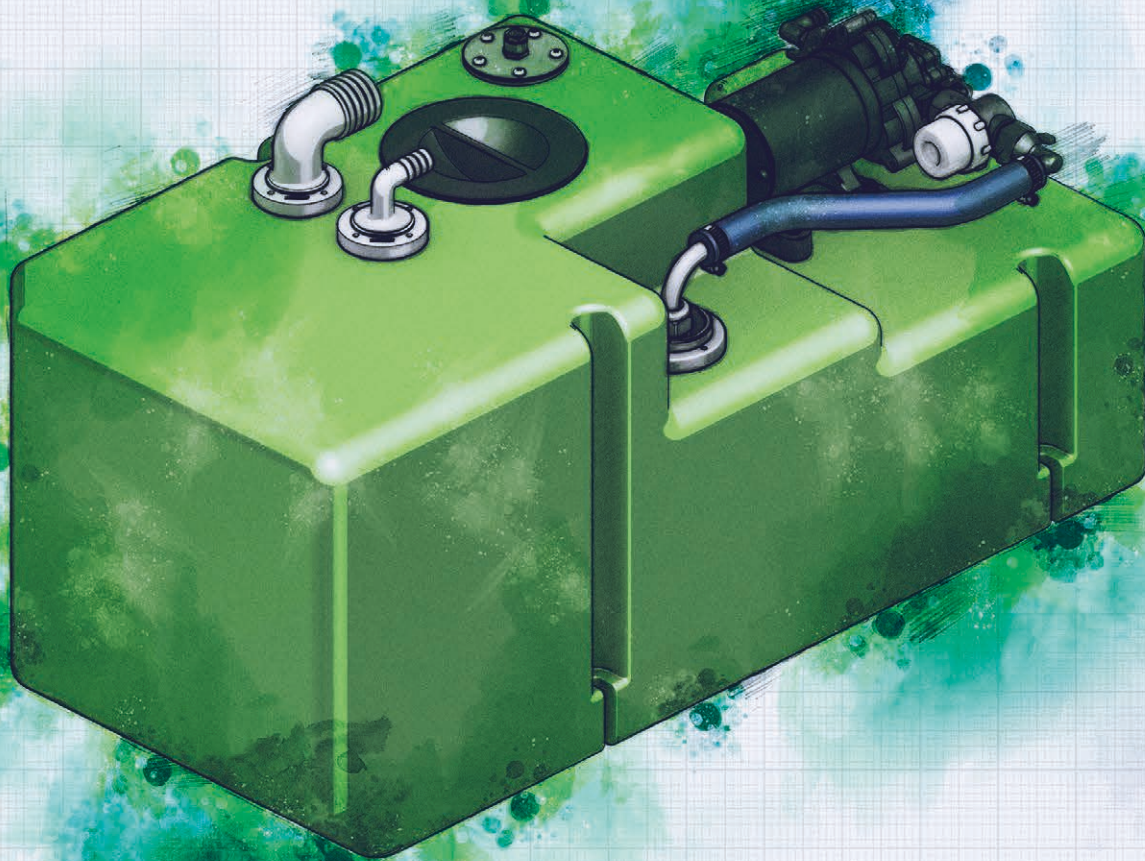

Overview VETUS fresh water systems

Rigid tanks see page 139



Flexible tanks see page 141



Water heater/calorifiers see page 142



Pressurized water systems see page 144



Pressurized water system pumps see page 145



Accumulator tank see page 145



Accessories see page 146



Accessories for hot water systems see page 148



WHY VETUS FRESH WATER SYSTEMS?

Clean fresh water is life's number one necessity. Therefore you should always have the best quality of water on board. The quality of the components selected for the on-board fresh water system, will determine how long the stored water remains safe and potable. VETUS uses sophisticated materials to make sure the drinking water stays fresh longer.

Why you should choose a VETUS fresh water system

- Our water tanks are made of synthetic material, perfect for drinking water
- Our tanks can be cleaned easily because of the large inspection covers
- We offer complete water pressure systems with integral pump and water pressure control
- Our electrical components are available for 12 and 24 Volt systems
- Our systems are quick and easy to install
- Our tanks are available in a range of capacities
- Our tanks avoid all of the corrosion problems associated with metal tanks

VETUS offers the following products for a good working fresh water system

Rigid tanks

High-grade synthetic tanks, especially designed for use with drinking water. Available in different shapes, sizes and capacities.

Ready-to-go tanks

These tanks are equipped as standard with an electric water pump, tank gauge sender, inspection lid and all connections required for the filler, suction and breather hoses.

Flexible water tanks

These tanks are made of durable material and can be easily installed and positioned in places which are normally difficult to reach. Ideal when space is a problem.

Calorifiers

To create hot water when the engine is running. Fresh water will heat up 5-7 times faster than with conventional designs.

Pressurised water systems

Provides a constant water flow in the vessels fresh water circuit.

Accessories

Hoses, connection kits, level sensors and tank gauges to complete the system.

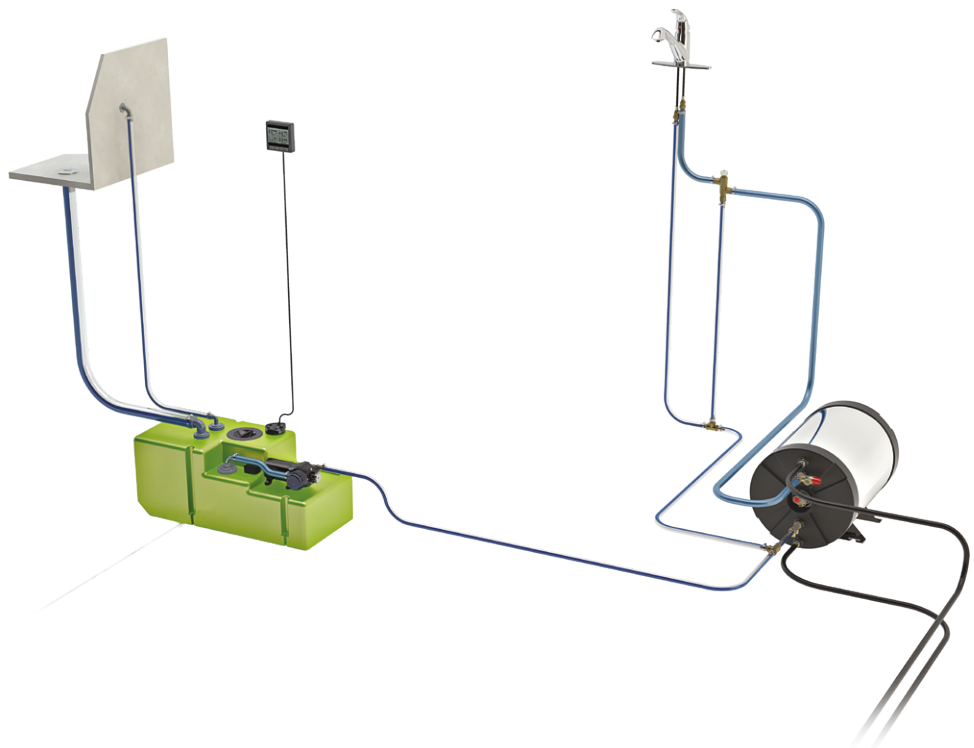

RIGID TANKS FOR DRINKING WATER

Basic tank type ATANK

Multi-purpose tank ideal for waste water, drinking water and diesel

These tanks are made of thick walled high-grade polyethylene which is both rust free and less prone to condensation compared to metal tanks. Due to the seamless construction of the tanks, leakage is impossible. Fittings can be installed wherever you choose and can be ordered separately.

Tanks are supplied with diesel, fresh water and waste water labels.

For more information, specifications and dimensions see page 129.

ATANK



Basic tank type WTANKC

With easy screw down inspection lid

This type is made of high grade synthetic like all other VETUS rigid drinking water tanks and is supplied with all required connections which saves considerable installation time. A centre point for a SAE flange gauge sender is incorporated in the moulding together with 5 blind bolt holes.

Specifications

- Tank capacities of 10.5 gal. (40 litres), 15.5 gal. (60 litres) or 21 gal. (80 litres)
- Hose connectors for filling line $\text{\O} 1\frac{1}{2}$ " (38 mm) and breather line $\text{\O} \frac{5}{8}$ " (16 mm)
- Rotating hose connector $\text{\O} \frac{1}{2}$ " (13 mm) with pick-up pipe for water suction
- Supplied with installed screw down inspection lid

Note

The gauge sender should be ordered separately and the appropriate hole cut in the tank.

Dimensions: plus or minus 2%
Height dimension includes connectors

WTANKC

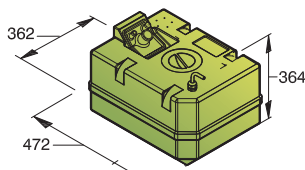

40 L

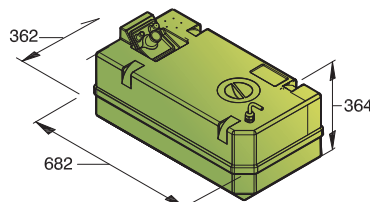

60 L

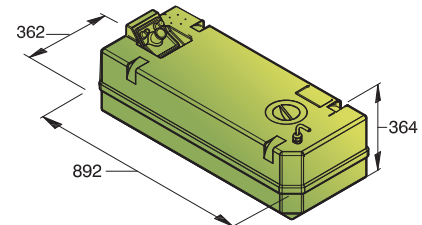

80 L

Type	Tank capacity gal. (litres)	\O Filler connection inches (mm)	\O Breather connection inches (mm)	\O Outlet connection inches (mm)
WTANK40C	10.5 (40)	1½ (38)	5/8 (16)	½ (13)
WTANK60C	15.5 (60)	1½ (38)	5/8 (16)	½ (13)
WTANK80C	21 (80)	1½ (38)	5/8 (16)	½ (13)

RIGID TANKS FOR DRINKING WATER

Drinking water system type DWSC

Comfort 'ready to go' system

This high grade synthetic tank for drinking water is supplied with an electric pump which automatically switches on when the pressure in the system drops (for example when a tap is opened).

Specifications

- Tank capacity of 11 gal. (42 litres), 16 gal. (61 litres), 23 gal. (88 litres) and 31.5 gal. (120 litres)
- Pump motor is available for 12 or 24 Volt
- Output 3.5 gal./min (13,2 ltr/min) at zero head
- Connections for filling line \varnothing 1 1/2" (38 mm), outlet line \varnothing 1/2" (13 mm) and ventilation line \varnothing 5/8" (16 mm)
- Also supplied with inspection cover, float sensor, connectors and filter in suction line

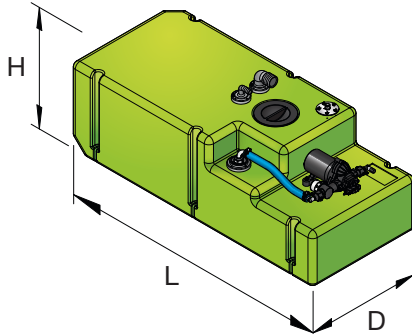

DWSC

Type	Tank capacity gal. (litres)	Voltage	\varnothing Filler connection inches (mm)	\varnothing Breather connection inches (mm)	\varnothing Outlet connection inches (mm)	Pump capacity g/min (l/min)	Pump pressure PSI (Bar)	L Length inches (mm)	D Depth inches (mm)	H Height inches (mm)
DWSC04212	11.1 (42)	12	1 1/2 (38)	5/8 (16)	1/2 (13)	3.49 (13,2)	44.96 (3.1)	24 (610)	13 3/4 (350)	15 3/4 (400)
DWSC04224	11.1 (42)	24	1 1/2 (38)	5/8 (16)	1/2 (13)	3.49 (13,2)	44.96 (3.1)	24 (610)	13 3/4 (350)	15 3/4 (400)
DWSC06112	16.11 (61)	12	1 1/2 (38)	5/8 (16)	1/2 (13)	3.49 (13,2)	44.96 (3.1)	30 11/16 (780)	13 3/4 (350)	15 3/4 (400)
DWSC06124	16.11 (61)	24	1 1/2 (38)	5/8 (16)	1/2 (13)	3.49 (13,2)	44.96 (3.1)	30 11/16 (780)	13 3/4 (350)	15 3/4 (400)
DWSC08812	23.25 (88)	12	1 1/2 (38)	5/8 (16)	1/2 (13)	3.49 (13,2)	44.96 (3.1)	36 5/8 (930)	15 3/4 (400)	15 3/4 (400)
DWSC08824	23.25 (88)	24	1 1/2 (38)	5/8 (16)	1/2 (13)	3.49 (13,2)	44.96 (3.1)	36 5/8 (930)	15 3/4 (400)	15 3/4 (400)
DWSC12012	31.7 (120)	12	1 1/2 (38)	5/8 (16)	1/2" (13)	3.49 (13,2)	44.96 (3.1)	41 5/16 (1050)	17 11/16 450	15 3/4 (400)
DWSC12024	31.7 (120)	24	1 1/2 (38)	5/8 (16)	1/2" (13)	3.49 (13,2)	44.96 (3.1)	41 5/16 (1050)	17 11/16 450	15 3/4 (400)

APT100 - One tank for all purposes

Fresh water, waste water or diesel: this tank can handle it

A new series of all-purpose tanks is introduced by VETUS: meet the APT100. Made from high-grade polyethylene, this large capacity tank handles almost any liquid you would like to store on your boat. It features an inspection lid and is ready for the appropriate ILT connection kit. On the bottom is a 1 1/2" (38 mm) connection that can be drilled out for interconnection purpose or draining. The robust appearance and the all-new design make this the tank to have.

Due to the large inspection hole (5 1/2" - 140 mm) the tank meets ISO 21487 when it comes to fuel directives. Depending on the purpose you have for this tank, an appropriate connection set is available from VETUS. The tank is easy to install and has enough capacity for longer boat trips.

Specifications

- All-purpose 100 litre tank, suitable for fresh water, waste water or diesel
- Made from high-grade polyethylene
- Large inspection port to meet ISO 21487 requirements
- 1 1/2" (38 mm) connection (to drill open) for interconnection purpose or draining
- ILT-concept ready



Typ	Tank capacity gallons (ltr)	Dimensions inches (mm)	Wall thickness inches (mm)	\varnothing Bottom connection inches (mm)
APT100	26.4 (100)	39 3/4 x 15 3/8 x 12 3/8 (1010 x 390 x 315)	5/16 (8)	1 1/2 (38)

APT100

FLEXIBLE TANKS FOR DRINKING WATER

Type TANKW

Easy installation

These tanks can be installed easily and quickly; they assume the shape of the space in which they are placed. Often they can be used in awkward spaces or difficult to reach locations. All fittings are supplied as standard and fitting the outlet nipple and connecting the inlet and outlet hoses are the only things that need to be done.

Standard supplied with

- 1 Right angle connector for filling pipe \varnothing 1 1/2" (38 mm) (is fitted to the top of the tank)
- 1 Right angle connector for the pump hose \varnothing 5/8" (16 mm) (loose)

Additional nipples can be supplied as an option.



TANKW

The VETUS flexible water tanks consists of three layers

1. A wear resistant layer
2. A reinforcement layer
3. A layer suitable for contact with drinking water

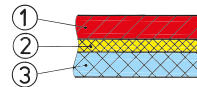

Type	Capacity (appr.) gallon	Dimensions (appr.) inches (mm)	Height filled (appr.) inches (mm)
TANKW55	14.5 gal. (55 litres)	26 ⁴⁹ / ₆₄ x 30 ⁴⁵ / ₆₄ (680 x 780)	9 ²⁷ / ₃₂ (250)
TANKW70	18.49 gal. (70 litres)	30 ⁴⁵ / ₆₄ x 30 ⁴⁵ / ₆₄ (780 x 780)	10 ⁵ / ₈ (270)
TANKW100	26.42 gal. (100 litres)	31 ⁷ / ₆₄ x 39 ³ / ₈ (790 x 1000)	10 ⁵ / ₈ (270)
TANKW160	42.27 gal. (160 litres)	46 ¹ / ₁₆ x 58 ²¹ / ₃₂ (790 x 1420)	10 ⁵ / ₈ (270)
TANKW220	58.12 gal. (220 litres)	31 ⁷ / ₆₄ x 55 ²⁹ / ₃₂ (740 x 2040)	10 ⁵ / ₈ (270)
TANKW1003	26.42 gal. (100 litres) (Δ)	29 ⁹ / ₆₄ x 80 ⁵ / ₁₆ (1170 x 1490)	9 ²⁹ / ₆₄ (240)

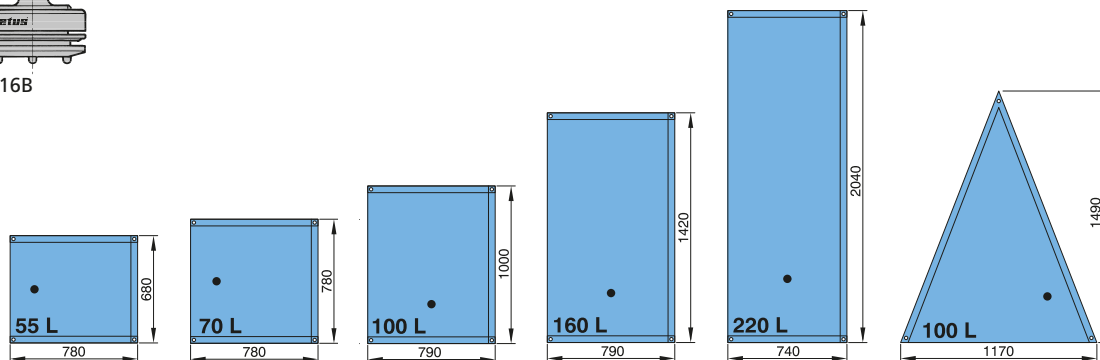
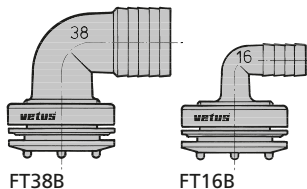

We not only weld the seams, but in addition we also weld an extra strip (see drawing A). This makes the VETUS flexible tank resistant against much higher pressures, especially if the contents are moving when the boat is rolling or pitching.



WATER HEATERS / CALORIFIERS

Improved standard twin coil calorifiers type WHT

This twin coiled calorifier range will double your comfort on board when it comes to hot water. One heating coil can be connected to the engine cooling circuit to make use of surplus engine heat. The other coil can be connected to an on board heating system. All calorifiers are supplied with; a 1500 Watt electric heating element, all hose connectors and a 6 bar pressure relief valve.

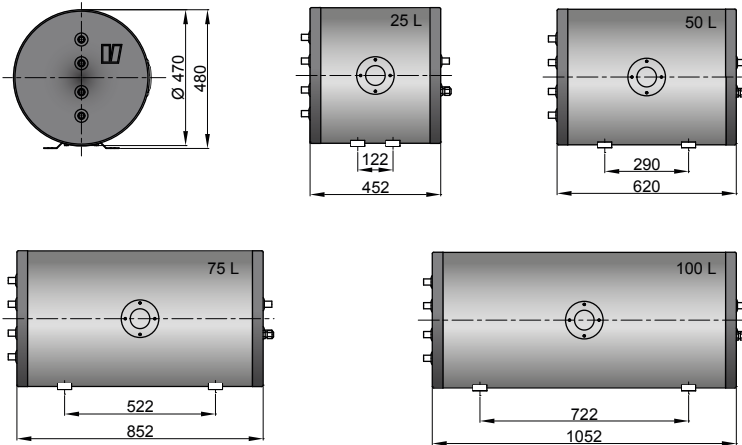

Contents of fresh water: 6.6 gal. (25 litres)
Contents of coolant: 0.13 gal. (0.5 litres)

WHT025

Contents of fresh water: 19.81 gal. (75 litres)
Contents of coolant: 0.13 gal. (0.5 litres)

WHT075

Contents of fresh water: 13.21 gal. (50 litres)
Contents of coolant: 0.13 gal. (0.5 litres)

WHT050

Contents of fresh water: 26.42 gal. 100 litres)
Contents of coolant: 0.13 gal. (0.5 litres)

WHT100

Specifications WHT

Construction

Tank	Duplex stainless steel
Insulation	Polyurethane foam, 1 ³ / ₂ " (50 mm) thickness Supplied with white painted steel outer jacket

Connections

Engine coolant	G 1/2
On-board heating system	G 1/2
Fresh water	G 1/2
Heating element	G 1 1/4, 1500 Watt, 230 V
Pressure relief valve setting	6 bar (87 lbs / sq.inch)

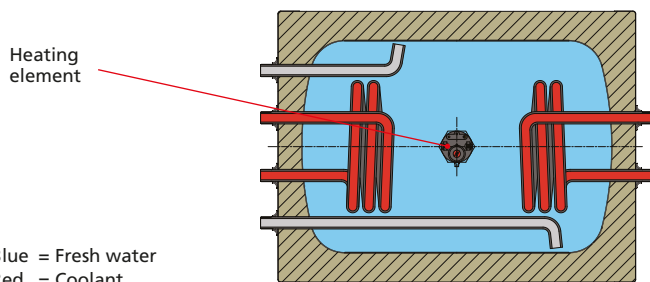

Blue = Fresh water
Red = Coolant

WATER HEATERS / CALORIFIERS

Premium double wall calorifiers type WHD

Whilst conventional calorifiers use a spiral tube to heat the water, these calorifiers use a very efficient double wall principle. Thanks to this double wall principle, the VETUS double wall calorifiers have a heating surface, which is much greater than that of a conventional heating spiral tube. This means that the double walled calorifiers will heat the water significant faster than conventional calorifiers. All calorifiers are supplied with; a 1500 Watt electric heating element, all hose connectors and a 6 bar pressure relief valve.

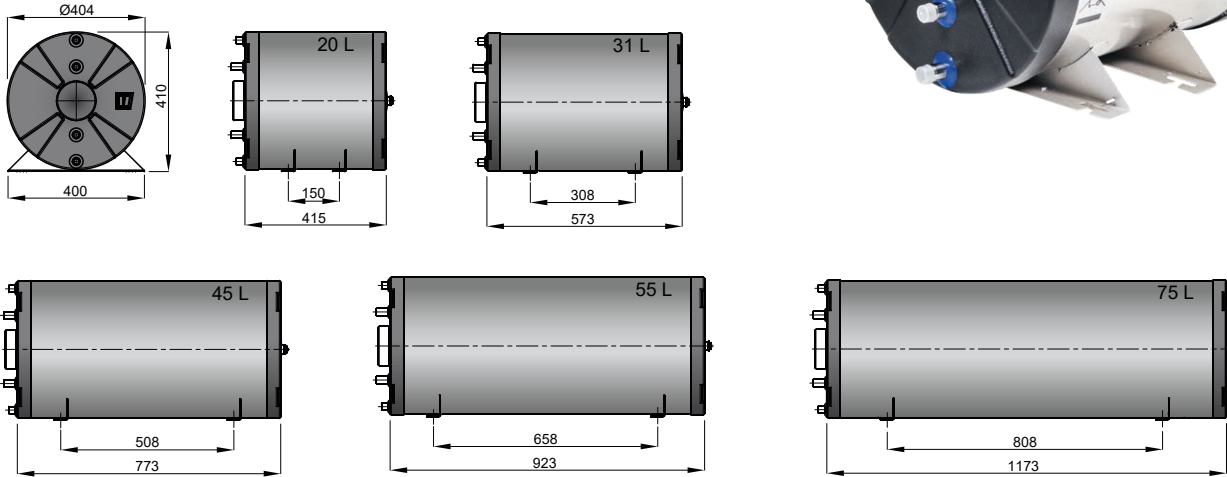

Contents of fresh water: 5.28 gal. (20 litres)
Contents of coolant: 0.53 gal. (2 litres)

WHD020

Contents of fresh water: 14.53 gal. (55 litres)
Contents of coolant: 1.85 gal. (7 litres)

WHD055

Contents of fresh water: 8.19 gal. (31 litres)
Contents of coolant: 0.79 gal. (3 litres)

WHD031

Contents of fresh water: 19.81 gal. (75 litres)
Contents of coolant: 2.38 gal. (9 litres)

WHD075

Contents of fresh water: 11.89 gal. (45 litres)
Contents of coolant: 1.32 gal. (5 litres)

WHD045

Specifications WHD

Construction

Inner + outer tank

Stainless steel, AISI 316L

Insulation

Polyurethane foam, 1 3/8" (35 mm) thickness Supplied with high gloss finished stainless steel outer jacket

Connections

Engine coolant

G 1/2

Fresh water

G 1/2

Heating element

G 1 1/4, 1500 Watt, 230 V

Pressure relief valve setting

6 bar (87 lbs / sq.inch)

Heating element

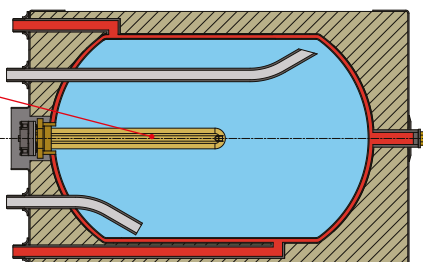

Blue = Fresh water
Red = Engine coolant



PRESSURIZED WATER SYSTEMS

Pressurized water system type HF

Ensuring constant water flow

This VETUS pressurized water system provides a constant flow in the vessels fresh water circuit. It is comparable with a piped water system at home. The pressurized tank with a rubber diaphragm inside, prevents the pump motor being started each time a supply of water is required. The diaphragm is suitable for drinking water and can be replaced. This system ensures a constant water flow, saving of energy and minimum noise.

Supplied with

- Self-priming pump
- Inlet water strainer
- Pressure switch
- Mounting bracket



HF

Extremely low noise level

Water system	Type HF1208 - HF2408	Type HF1219 - HF2419
Contents of pressure tank	2.11 gal. (8 litres)	5.02 gal. (19 litres)
Available in	12 Volt (3,9 A) 24 Volt (2,0 A)	12 Volt (6 A) 24 Volt (2,5 A)
Connection for hose	Ø ½ inch (13 mm)	Ø ¾ inch (19 mm)
Weight	13.67 lbs (6,2 kg)	16.53 lbs (7,5 kg)
Capacity	3.30 gpm (12,5 l/min.)	4.49 gpm (17 l/min.)
Max. pressure	2,5 bar (35 psi)	2,8 bar (39 psi)
Max. suction height	9.8 ft (3 m)	9.8 ft (3 m)

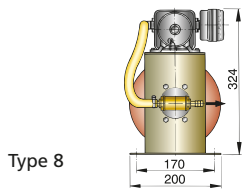

Type 8

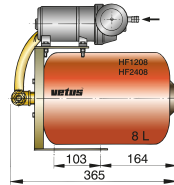

Type 19

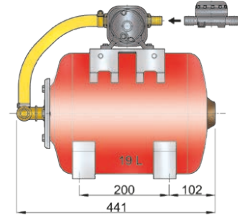
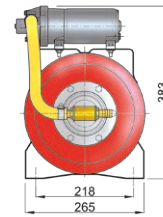

Pressurized water system type HYDRF

With adjustable pressure switch

Type HYDRF works the same as the basic pressurized water system type HF, but has an adjustable pressure switch, a manometer (pressure gauge) and an additional non-return valve. Both VETUS pressurized water systems meet the EMC requirements. For more information about this pressurized water system, see type HF.



HYDRF

Water system	Type HYDRF12 - 24	Type HYDRF1219 - 2419
Contents of pressure tank	2.11 gal. (8 litres)	5.02 gal. (19 litres)
Available in	12 Volt (3,9 A) 24 Volt (2,0 A)	12 Volt (6 A) 24 Volt (2,5 A)
Connection for hose	Ø ½ inch (13 mm)	Ø ¾ inch (19 mm)
Weight	18.08 lbs (8,2 kg)	20.94 lbs (9,5 kg)
Capacity	3.30 gpm (12,5 l/min.)	4.49 gpm (17 l/min.)
Max. pressure	2,5 bar (35 psi)	2,8 bar (39 psi)
Max. suction height	9.8 ft (3 m)	9.8 ft (3 m)

Extremely low noise level

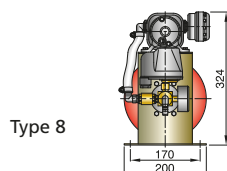

Type 8

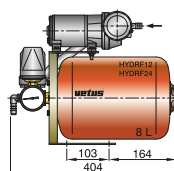

Type 19

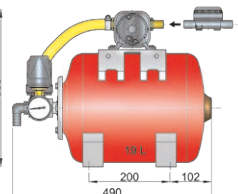
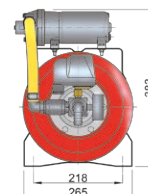

PRESSURIZED WATER SYSTEMS

Pressurized water system pumps type WP

Silent running and smooth operation

These pumps are designed for pressurized water systems, washing, liquid transfer etc. Type WP is noiseless, low in energy consumption and can run dry without damage. It is well equipped with a thermal overload protection, built-in check valve and is auto demand with built-in pressure switch. This pump is supplied with 2 straight and 2 angled 1/2" (13 mm) hose connections and inlet filter.

For voltage, flow, pressure, current and dimensions see table below.

Type	Volt (V)	Flow	Pressure	Max Current (A)	L x W x H inch (mm)
WP1208	12	2 gpm (7.6 lpm)	30.5 PSI (2.1 Bar)	5	8 11/32 x 5 1/8 x 4 27/32 (212 x 130 x 123)
WP2408	24	2 gpm (7.6 lpm)	30.5 PSI (2.1 Bar)	3	8 11/32 x 5 1/8 x 4 27/32 (212 x 130 x 123)
WP1213	12	3.5 gpm (13.2 lpm)	45 PSI (3.1 Bar)	7	8 11/32 x 5 1/8 x 4 27/32 (212 x 130 x 123)
WP2413	24	3.5 gpm (13.2 lpm)	45 PSI (3.1 Bar)	4	8 11/32 x 5 1/8 x 4 27/32 (212 x 130 x 123)
WP1220	12	5.3 gpm (20 lpm)	61 PSI (4.2 Bar)	17	9 x 5 25/32 x 5 13/64 (229 x 147 x 132)
WP2420	24	5.3 gpm (20 lpm)	61 PSI (4.2 Bar)	10	9 x 5 25/32 x 5 13/64 (229 x 147 x 132)



WP.08

WP.13



WP.20

Accumulator tank type EXPAT075

Steady water pressure in the system

Made from high grade polyamide, this compact small capacity accumulator with rubber membrane provides a constant flow in the vessels water circuit. The pressure in the accumulator prevents the water pump motor being started each time a supply of water is required and the butyl rubber membrane is suitable for drinking water. Connecting is easy as there is no preferred IN or OUT connection on this accumulator.

The EXPAT075 ensures a constant water flow, saves energy and minimizes noise. The accumulator is set to a pre-charge pressure of 0,7 bar, but can be adjusted to optimal settings for your fresh water system (to a maximum of 8,5 bar). Overall dimensions are 8 3/4 x 7 5/8 x 4 1/2" (223 x 194 x 114 mm) and the accumulator is supplied with two angled and two straight 13 mm hose pillars.

Specifications

- Smooths water flow
- Extends the lifespan of your fresh water pump
- Tank is suitable for confined spaces
- Dampens pulsation in the system
- Volume: 0,75 litre
- Temperature range: 0 to 122°F (0 to 50°C)
- Connections: 1/2" NPT Male
- Hose pillars: 1/2" NPT - 1/2" (13 mm) hose
- Weight: 0,36 kg



EXPAT075

Typ	Capacity (l)	Max. pressure (bar)	Connections inches (mm)	Dimensions l x b x h inches (mm)
EXPAT075	0,75	8,5	1/2 (13) hose	8 3/4 x 7 5/8 x 4 1/2 (223 x 194 x 114)



ACCESSORIES

Hose type DWHOSEB

Temperature proof between 41 and 149°F (-5 and +65°C)

This hose is made of transparent PVC with spiral inlay and is suitable for transportation of drinking water on board, both suction and pressure.

For a complete overview, specifications and dimensions of hoses see page 404.



DWHOSEB

Hose type HWHOSE

Ideal for use with calorifier and hot water systems

Type HWHOSE is made of EPDM rubber with an inlay of woven synthetic fabric. This hose is suitable for drinking water and is temperature resistant between -22 and 320°F (-30 and + 160°C).

For a complete overview, specifications and dimensions of hoses see page 404.



HWHOSE

Inspection lid type WTK02

For (waste) water tanks only!

Specifications

- Overall diameter 6 9/64" (156 mm)
- Cut out diameter 4 17/32" (115 mm)
- Not suitable for fuel tanks
- Ideal for metal tanks



WTK02

Type	Description
WTK02	Inspection lid only, for rigid drinking water tanks

Inspection lid kit type WTIKIT

Complete with gasket, counter flange and fastenings

Specifications

- Overall diameter 6 9/64" (156 mm)
- Cut out diameter 4 17/32" (115 mm)
- Not suitable for fuel tanks

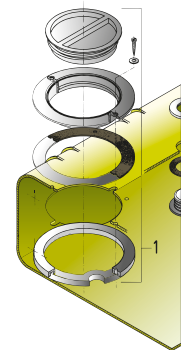

WTIKIT

Type	Description
WTIKIT	Inspection lid for rigid drinking water tanks

Ultrasonic level sensor type SENSORA

Easy measurement

This VETUS ultrasonic level sensor is contactless and will easily measure the fluid level in the tank.

For more information and available level sensors see page 109.



SENSORA

Type	Description
SENSORA	Ultrasonic level sensor

ACCESSORIES

Installation kit type WTKIT

With inspection lid and angled connectors

The installation kit consists of

1. 1 Inspection lid (WTKIT)
2. 1 Right angle connector (RT38B) for filling hose $\text{\O} 1\frac{1}{2}$ " (38 mm)
3. 1 Right angle connector (RT16B) for water pump $\text{\O} \frac{5}{8}$ " (16 mm)
4. 1 Right angle connector (RT16B) for ventilation $\text{\O} \frac{5}{8}$ " (16 mm)
5. 2 Mounting straps
6. T-piece for interconnecting 2 tanks $\text{\O} \frac{5}{8}$ " (16 mm)

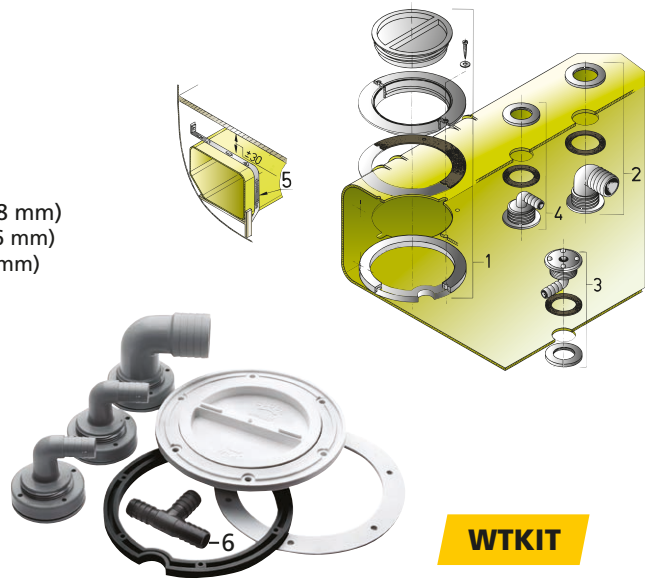

WTKIT

Type	Description
WTKIT	Installation kit for drinking water tanks

Universal inspection port for tanks type ILT120

Innovative inspection port with robust design

The standard delivery of the VETUS ILT is an innovative port with flange-in-ring design which facilitates easy opening, inspecting and cleaning the tank, even after being closed for a long time. The inspection port has a counter flange and a rubber seal which are inserted into a $\text{\O} 6\frac{1}{4}$ " (159 mm) hole in the tank. All that needs to be done is tighten the 4 supplied bolts which compresses the rubber seal to ensure perfect sealing.

The "clamp and seal" design simplifies installation, making the drilling of a $\text{\O} 6\frac{1}{4}$ " (159 mm) hole the hardest part in the installation!
The black blind plate can be replaced by various connection kits.

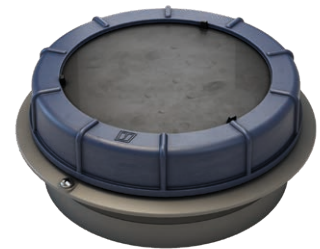

ILT120

Fresh water connection kit type ILTCOND

Keeping fresh water fresh and preventing marine growth can be tricky, but a large opening will help to do the job! Periodic cleaning of all connections and of course the tank itself will be a much easier job if it can be done in a fraction of the time!
For drinking water tanks in all varieties the VETUS ILT freshwater disc is all you need!

The connections that come with this set are

- $\text{\O} 1\frac{1}{2}$ " (38 mm) fresh water fill connection
- $\text{\O} \frac{1}{2}$ " (13 mm) fresh water suction connection
- Ventilation connection $\text{\O} \frac{5}{8}$ " (16 mm)
- 5 hole SAE flange tank level sensor connection



ILTCOND

Type	Description	Diameter inches (mm)	Diameter hole inches (mm)
ILT120	Inspection port with counter flange	4 $\frac{3}{4}$ " (120)	6 $\frac{1}{4}$ (159)
VSAW159	$\text{\O} 6\frac{1}{4}$ " hole saw for plastic, G.R.P. or metal tanks		6 $\frac{1}{4}$ (159)
ILTCOND	Fresh water connection kit		

ACCESSORIES

Suction pipe type WTS44513B

Fitted to the top of fixed tanks

This suction pipe can be fitted to the top of most of the fixed tanks with a maximum depth of $\text{Ø } 1 \text{ ft } 4 \frac{9}{64}''$ (410 mm) and is suitable for $\text{Ø } \frac{1}{2}''$ (13 mm) drinking water systems.



Type	Description
WTS44513B	Suction pipe for drinking water tanks

WTS44513B

ACCESSORIES FOR HOT WATER SYSTEMS

Heating element type WHEL

Adjustable thermostat 104 - 176°F (40 - 80°C.). Male thread size, ISO 228/1 G1¼. Screw-in length of element is $11 \frac{13}{16}''$ (300 mm).

Electric heating elements

- 500 Watt, 230 Volt
- 1000 Watt, 120 Volt
- 1000 Watt, 230 Volt
- 1500 Watt, 230 Volt

VETUS heating elements type WHEL meet the low voltage requirements.

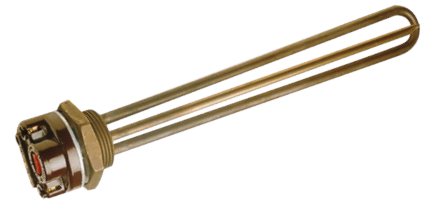

WHEL

Type	Volt (V)	Watt
WHEL22500	230	500
WHEL220	230	1000
WHEL110	120	1000
WHEL1500	230	1500

Thermostatic mixer for calorifiers

Calorifiers which are heated by the engine coolant, can deliver their fresh water contents at temperatures of more than 194°F (90°C). There is always a risk that these high temperatures could cause scalding when washing or showering. Using a mixer tap can take too long to find a suitable temperature, with high water usage as a consequence.

By fitting a thermostatic mixer, the risk of scalding is eliminated and a safe and comfortable temperature for each requirement is easily selected. So, no more hot water wastage, a constant safe temperature at the tap and energy saving.

The thermostatic mixer is provided with G½ thread. The temperature is infinitely adjustable between 86 and 158°F (30 and 70°C).



WHMIXER

Type	Description
WHMIXER	Thermostatic mixer for calorifiers

WASTE WATER SYSTEMS

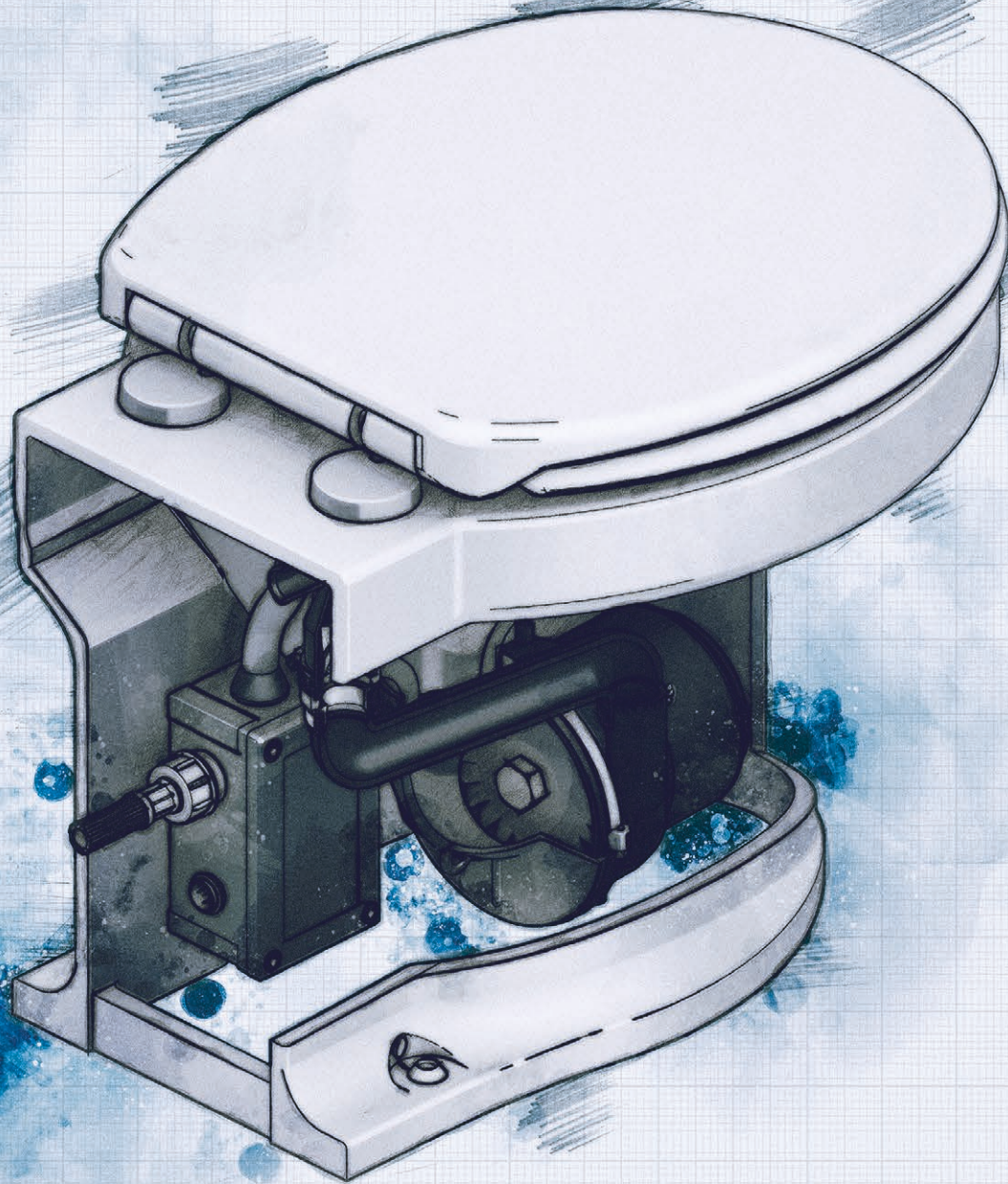

Overview VETUS waste water systems

Electric marine toilets see page 153



Electric toilet control panels see page 156



Sani-processors see page 157



Rigid tanks for waste water see page 159

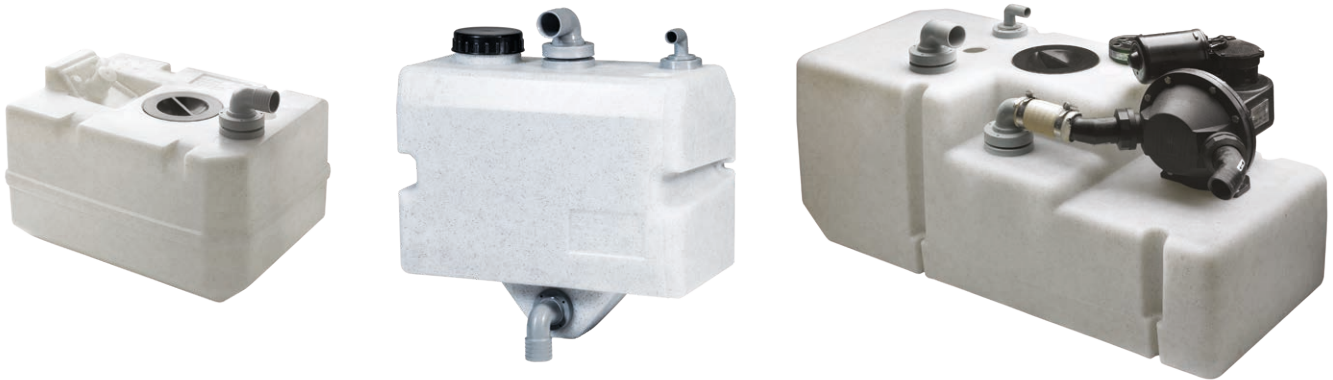

Flexible waste water tanks see page 162



TankFresh see page 162



Accessories for waste water holding tanks see page 163



WHY VETUS WASTE WATER SYSTEMS?

An odourless waste water system is possible, however, you do need to follow some guidelines to keep your waste water free from unwanted odours. Below we highlight a few tips. You can also download the VETUS guide from the VETUS website with more suggestions to keep your waste water system free of odours.

Tips for an odour-free waste water system

1. Hoses: Make sure the outlet hoses are properly installed with a constant fall towards the holding tank. Flush the hoses thoroughly with sufficient fresh water every time the toilet is used.
2. Flushing: Flush your hoses sufficiently. Installing a VETUS electric toilet also helps. These toilets have a powerful macerator pump that ensures all waste water is pumped through the hoses at high pressure, and less water is needed to flush them.
3. Holding tank: Use VETUS holding tanks. The thick walls of our synthetic tanks make them completely odour proof. The hose connection kit and fittings with watertight seals ensure that no leaks can occur. Empty and rinse the tank regularly. All VETUS waste water tanks are certified according ISO 8099.
4. Ventilation: Proper ventilation is the main requirement for an odourless system. It is very important that the tank is well ventilated. Use large diameter fittings and VETUS hoses for ventilation. Make sure that the hoses are not clogged! As an option you can install a No-Smell filter in the ventilation hoses.
5. TankFresh: A concentrate of completely organic bacteria that break down faeces in the waste water system without emitting any odour. Any well-designed waste water system can function virtually without odour just by using TankFresh.

Why you should choose a VETUS waste water system

VETUS WWS waste water system

- Is easy to install, low maintenance and space-saving
- Comes pre-fitted with pump, discharge pipe, breather, inspection lid and ultrasonic sensor
- Is robust and corrosion-free and available in capacities of 11 (42), 6 (61), 23 (88) and 31 (120) gallon (litres)

VETUS EMP 140 waste water pump

- Is a powerful diaphragm pump equipped with 'duck bill' valves
- Produces very low noise levels, is self-priming and low maintenance
- Comes complete with rotatable connectors allowing hose connections from any angle
- Has a large capacity of 7 (27) gallon(litres)/minute, suction height 9 feet (3 metres), discharge height 16 feet (5 metres)

VETUS electric toilets

- Come with high quality seat and cover and operate at the touch of a button
- Low maintenance and low water consumption (ECO flush)
- Feature a very low noise macerator and pump and require only a 3/4" (19 mm) diameter outlet pipe
- Equipped with stainless steel (AISI 316) macerator blades, a waterlock and non-return valve
- VETUS electric marine toilets meet the EMC requirements

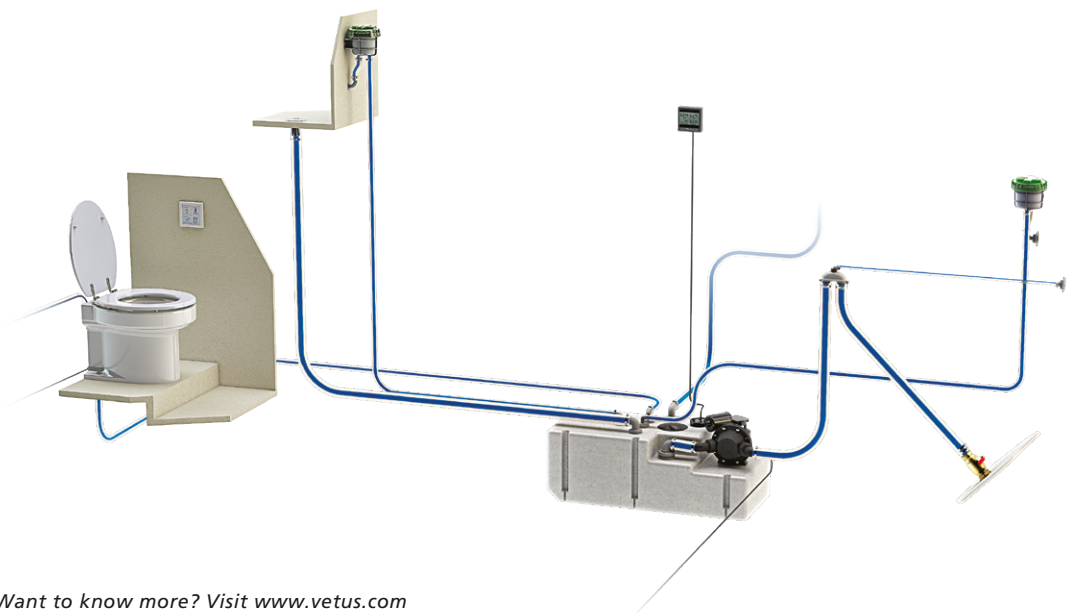

ELECTRIC MARINE TOILETS

Soft close toilet type TMWQ

Compact dimensions without sacrificing comfort

Very competitively priced and comfortable toilet. A welcome alternative to manually operated hand-pumped toilet. Operated by a simple rocker switch or control panel which must be ordered separately (see page 156).

Specifications

- Soft close and quick release seat / lid
- Easy to clean porcelain bowl / simple maintenance
- Powerful macerator with full stainless steel (AISI 316) blades and high capacity discharge pump (60dB (A))
- Comes with 3 discharge hose adapters $\text{\O}^{3/4}$ " (19 mm), 1" (25 mm) and 1 1/2" (38 mm) and a 2 7/16" (700 mm) water inlet hose
- Very low water consumption

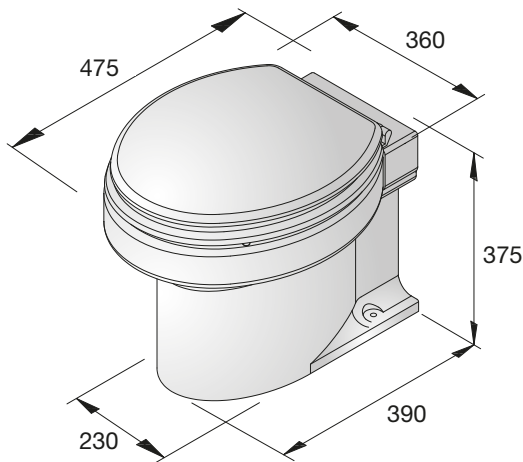

TMWQ

Type	Voltage (V)	Power consumption (A)	Type of control	External Ø discharge inches (mm)	Water inlet connection
TMW12Q	12	25	Of choice	3/4, 1 or 1 1/2 (19, 25 or 38)	Female G3/4
TMW24Q	24	12.5	Of choice	3/4, 1 or 1 1/2 (19, 25 or 38)	Female G3/4

ELECTRIC MARINE TOILETS

Hanging toilet type HATO

Creating more floor space

A practical wall mounted toilet without connection to the floor to simplify cleaning. This toilet has a porcelain bowl and a comfortable sized seat. The waste connection is in the back wall, which can be an advantage.

Specifications

- Easy to install and maintain
- Super quiet macerator (60dB (A)) with full stainless steel (AISI 316) blades and large capacity discharge pump
- Comes with a waterproof electronic operating panel or a pneumatic push button
- Very low water consumption
- Available for DC or AC power supply

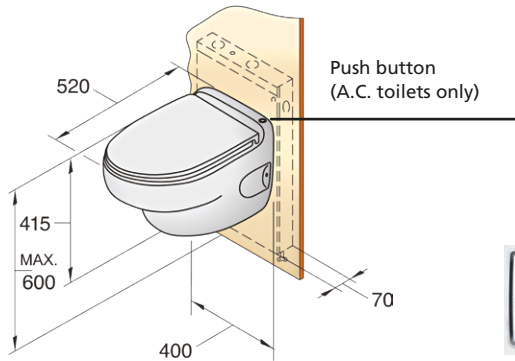

HATO212B

HATO224B



HATO

Toilet type WCS

Floor standing comfort

Comfortable floor standing toilet with porcelain bowl and a normal sized seat and lid.

Specifications

- Easy to install and maintain
- Super quiet macerator with full stainless steel (AISI 316) blades and large capacity discharge pump (60dB (A))
- Comes with a waterproof electronic operating panel or pneumatic push button
- Very low water consumption
- Available for DC or AC power supply

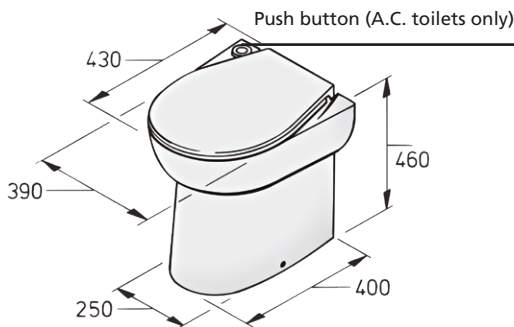

WCS12S2

WCS24S2



WCS

Type	Voltage (V)	Power consumption (A)	Type of control	External Ø discharge inches (mm)	Water inlet connection
HATO212B	12 V (DC)	25	Panel	¾ (19)	Female G¾
HATO224B	24 V (DC)	12.5	Panel	¾ (19)	Female G¾
HATO110	110 V (60 Hz)	5	Push button	¾ (19)	Female G¾
HATO220	230 V (50 Hz)	2.5	Push button	¾ (19)	Female G¾
WC12S2	12 V (DC)	25	Panel	¾ (19)	Female G¾
WC24S2	24 V (DC)	12.5	Panel	¾ (19)	Female G¾
WC110S	110 V (60 Hz)	5	Push button	¾ (19)	Female G¾
WC220S	230 V (50 Hz)	2.5	Push button	¾ (19)	Female G¾

ELECTRIC MARINE TOILETS

Toilet type SMTO

Small size, big performance

This is one of the smallest and lightest electric toilets on the market. A high-quality solid floor standing model, with a porcelain bowl and comfortable seat and lid.

Specifications

- Easy to install and maintain
- Super quiet macerator with full stainless steel (AISI 316) blades and large capacity discharge pump (60dB (A))
- Comes with a waterproof electronic operating panel (type SMTO2) or rocker switch (type SMTO2S)
- Very low water consumption

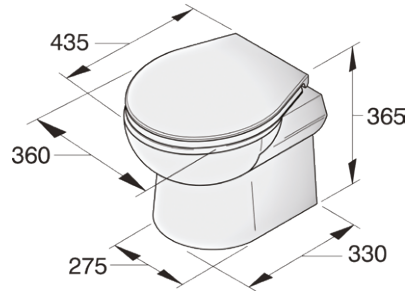

SMTO

SMTO2



SMTO2S



Compact toilet type WCP

Small footprint, big performance

This toilet has a very small footprint because the electronic control box is mounted outside the toilet.

Specifications

- Easy to install and maintain
- Super quiet macerator with full stainless steel (AISI 316) blades and large capacity discharge pump (60dB (A))
- Comes with a waterproof electronic operating panel (type WCP) or rocker switch (type WCPS)
- Very low water consumption



WCP

WCP



WCPS



Type	Voltage (V)	Power consumption (A)	Type of control	External Ø discharge inches (mm)	Water inlet connection
SMTO212	12	25	Panel	3/4 (19)	Female G ³ / ₄
SMTO224	24	12.5	Panel	3/4 (19)	Female G ³ / ₄
SMTO2S12	12	25	Switch	3/4 (19)	Female G ³ / ₄
SMTO2S24	24	12.5	Switch	3/4 (19)	Female G ³ / ₄
WCP12	12	25	Panel	3/4 (19)	Female G ³ / ₄
WCP24	24	12.5	Panel	3/4 (19)	Female G ³ / ₄
WCPS12	12	25	Switch	3/4 (19)	Female G ³ / ₄
WCPS24	24	12.5	Switch	3/4 (19)	Female G ³ / ₄



ELECTRIC TOILET CONTROL PANELS

Control panel for TMW toilet

Pre-programmed comfort

The panel is easy to operate with just 4 functions. It has an eco ($\pm 0,3$ gal (1,2ltr)) and normal flush ($\pm 0,6$ gal (2,2ltr)) button and a fill or empty bowl button. Using a marine toilet was never this easy, just touch the button!

Specifications

- Panel dimensions 4 21/64" x 4 21/64" (110 mm x 110 mm)
- Build-in depth 1 31/32" (50 mm)
- Complete installation package including 9.8 ft (3 mtr) cable
- Suitable for 12 or 24 Volt
- Waterproof IP65



TMWBWP

Control switch for TMW toilet

Full control over the flush

A simple and effective 2 functions switch to fill or empty the bowl.

Specifications

- Switch dimensions 3 5/64" x 1 27/32" (78 mm x 47 mm)
- Build-in depth 1 9/16" (40 mm)
- Complete installation package including 9.8 ft (3 mtr) cable
- Suitable for 12 or 24 Volt
- Waterproof IP65



TMWBWS

Marine toilet control panel

(Supplied with toilet types WCP, WCS, HATO and SMTO)

This pre-programmed 3 functions panel has an eco and normal flush and bowl evacuation.

Specifications

- Panel dimensions 2 7/8" (72 mm) x 2 7/8" (72 mm)
- Build-in depth 53/64" (21 mm)
- Complete installation package including 5 ft. (1.5 metres) cable
- Suitable for 12 or 24 Volt
- Waterproof IP65



Marine toilet rocker switch

(Supplied with toilet types SMTOS and WCPS)

Rocker switch with 2 functions to fill or flush the bowl.

Specifications

- Switch dimensions 1 3/4" (45 mm) x 3" (75 mm)
- Build-in depth 1 9/16" (40 mm)
- Complete installation package including 9.8 ft. (3 metres) cable
- Suitable for 12 or 24 Volt
- Waterproof IP65



Note

Toilet models WCP, WCS, HATO and SMTO are supplied with a control panel or rocker switch and do not need to be ordered separately.

All VETUS toilets are equipped with an electric pump with powerful macerator to ensure proper evacuation of contents in one single action.

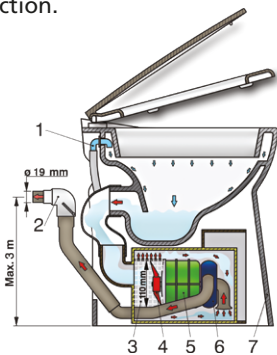

120/230 Volt models

1. Flushing water inlet
2. Discharge of waste water
3. Protective grille
4. Stainless steel (AISI 316) blades
5. Macerator motor
6. Discharge pump
7. Porcelain toilet bowl

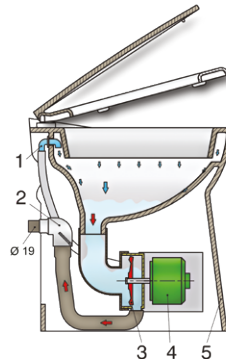

12/24 Volt models

1. Flushing water inlet
2. Discharge of waste water
3. Stainless steel (AISI 316) blades
4. Macerator motor
5. Porcelain toilet bowl

SANI-PROCESSOR

Compact Sani-Processor for black and grey water

The comfort and style of home

On larger boats owners want to have the comfort and looks of their toilet at home. Therefore VETUS has developed the Sani-Processor with an electric macerator and a powerful pump in order to use an ordinary gravity flow, domestic toilet on board. When flushing the toilet, the Sani-Processor collects the contents, macerates and pumps the slurry into a holding tank. The whole process takes only 10 to 30 seconds and is very quiet. The unit can be easily cleaned by removing the inspection lid. We recommend using the VETUS sanitary connecting hoses, type SAHOSE, to ensure an odour-tight process.

Specifications

- Processor dimensions 16 1/2" x 4 3/4" x 14 1/4" (420 x 120 x 360 mm) (l x w x h)
- Holding tank placement max. 13 ft (4 mtr) higher than Sani-Processor
- Macerator diameter 3 7/8" (98 mm)
- Weight 10.5 lbs (4.8 kg)
- Pump capacity approx. 13.2 gal. (50 l/min) at 13 ft. (4 m) head
- Power consumption approx. 370W (12V), 435W (24V), 580W (110V), 400W (230V)
- Available for 12 or 24 Volt DC, 230 Volt/50Hz or 120 Volt/60Hz
- Maximum permissible water temperature 95°F (35°C)

Connections

- Hose from toilet to Sani-Processor: Ø 4" (102 mm), max. length 13 ft. (4 m)
- Hose from Sani-Processor to holding tanks: Ø 3/4" (19 mm), max. length 65 ft (20 metres)
- Washbasin/bidet connections: Ø 1 9/16" (40 mm)



SAPRO

Type	Voltage
SAPRO12	12 Volt DC
SAPRO24	24 Volt DC
SAPRO220	230 Volt / 50 Hz
SAPRO110	120 Volt / 60 Hz

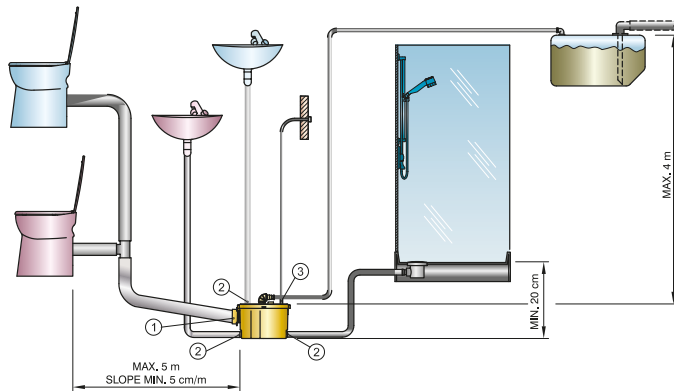

1. Hose connection 4" (102 mm) (SLVBR100K)
2. Hose connection Ø 1 9/16" (40 mm) (SLVBR40K or HA3060)
3. Hose connection HA1338

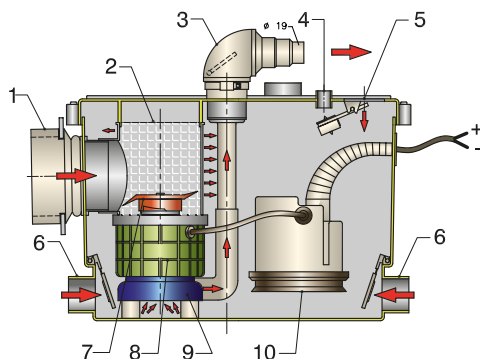

1. Toilet connection, Ø 4" (102 mm)
2. Protective grille
3. Waste discharge connections: male Ø 3/4" (19 mm) o.d. and female Ø 1" (25) / 1 1/8" (28) / 1 1/4" (32) mm i.d
4. Breather connection, Ø 3/4" (19 mm)
5. Washbasin / bidet connection, Ø 1 9/16" (40 mm)
6. Washbasin or shower connection, Ø 1 9/16" (40 mm)
7. Stainless steel (AISI 316) blades
8. Electric macerator motor
9. Discharge pump
10. Float switch



SANI-PROCESSOR

Discharge system to transport waste water into holding tank

Pumping water automatically from the shower tray or wash basin into a waste water tank is possible with the VETUS grey water discharge system (GWDS). It has a watertight housing with a low noise discharge pump, automatic flow switch and a non-return valve in the discharge line. You can easily pump the water into the holding tank.

Specifications

- Dimensions tank
11⁷/₈" (300) x 6¹/₂" (165) x 5³/₄" (145 mm)
(l x w x h)
- Waste water tank location up to 13 ft. (4 metres) above GWDS unit or up to 66 ft. (20 metres) away from it
- Bottom of GWDS unit must be placed at least 2³/₈" (6 cm) below shower tray or washbasin
- Weight 7.7 lbs (3.5 kg)
- Pump output approx. 11.6 gal. (44 litres/min)
- Power consumption approx. 340W (12V), 350W (24V), 600W (120V), 250W (230V)
- Available for 12 or 24 Volt DC, 230 Volt/50Hz or 120 Volt/60Hz
- Maximum permissible water temperature 95°F (35°C)

Connections

- Outlet discharge to holding tank: Ø 3/4" (19 mm)
- Inlet connections from shower or washbasin:
Ø 1¹/₄" (32 mm) or 1³/₁₆" (40 mm)



GWDS

Type	Voltage
GWDS12	12 Volt DC
GWDS24	24 Volt DC
GWDS220	230 Volt / 50 Hz
GWDS110	120 Volt / 60 Hz

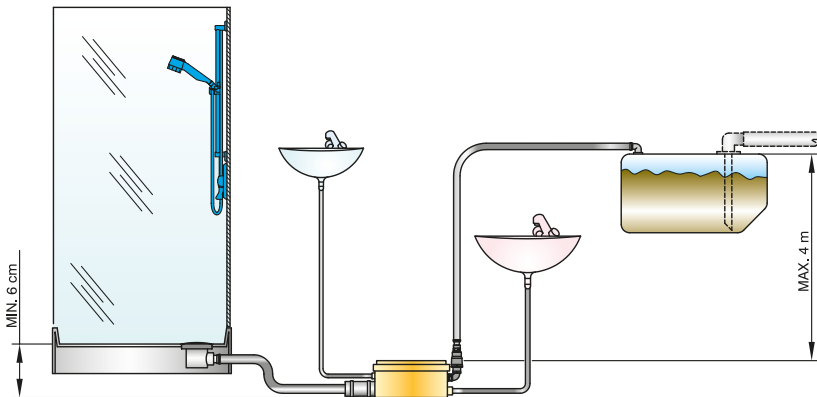

Hose connectors (1) HA1338 and (2) HA3060 are shown on page 165.

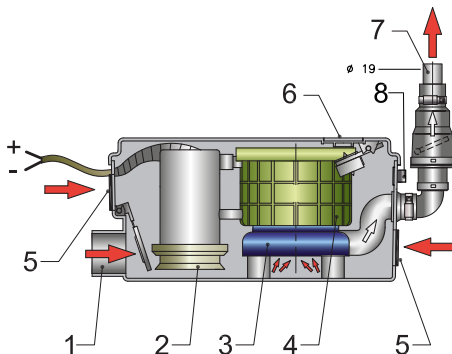

1. Shower or washbasin connection Ø 1³/₁₆" (40 mm)
2. Float switch
3. Discharge pump
4. Electric motor
5. Washbasin connection, Ø 1¹/₄" (32 mm) or 1³/₁₆" (40 mm)
6. Breather
7. Waste water discharge connection: male Ø 3/4" (19 mm) o.d
8. Air conditioner connection, Ø 1/2" (12 mm)

RIGID TANKS FOR WASTE WATER

Basic tank type ATANK

Multi-purpose tank ideal for waste water, drinking water and diesel

These tanks are made of thick walled high-grade polyethylene which is both rust free and less prone to condensation compared to metal tanks. Due to the seamless construction of the tanks, leakage is impossible. Fittings can be installed wherever you choose and can be ordered separately.

Tanks are supplied with diesel, fresh water and waste water labels.

For specifications and dimensions see page 129.

ATANK



Basic tank including connectors type BTANKC

These tanks will save considerable installation time!

These tanks are made of odour impermeable synthetic see-through material so the content level can be seen from the outside. The centre point for a SAE flange gauge sender has already been provided in the moulding, together with 5 bolt holes (except BTANK25C). This will save you considerable installation time. The tanks are supplied with connectors, a screw down inspection lid and 2 securing straps. The inlet fitting (type RT..B) should be ordered separately matching the inlet hose diameter.

Specifications

- Tanks are according to the ISO 8099 standard
- Tank capacities of 6.5 gal. (25 l.), 10.5 gal. (40 l.), 15.8 gal. (60 l.) or 21.2 gal. (80 l.).

Connections

- Fixed hose connector $\text{\O} \frac{3}{4}$ " (19 mm) for breather line, rotating for BTANK25C
- Rotating hose connector $1\frac{1}{2}$ " (38 mm) with pick-up pipe for suction
- Hole for inlet fitting type RT..B



BTANKC

Type	Suitable for	Capacity (gallon)
BTANK25C	Waste water	6.5
BTANK40C	Waste water	10.5
BTANK60C	Waste water	15.8
BTANK80C	Waste water	21.2

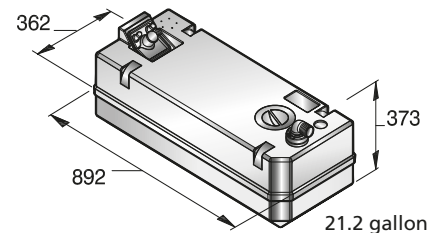
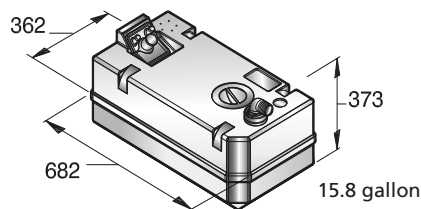
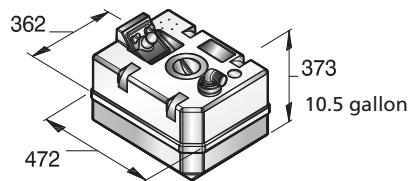
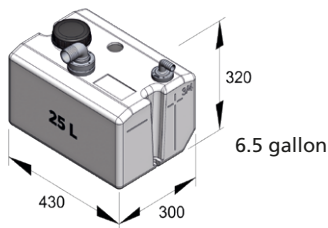

Dimensions: plus or minus 2%. Height dimensions includes connectors



RIGID TANKS FOR WASTE WATER

Bulkhead mounted tank type WW

Can be emptied without a pump

These tanks are made of odour impermeable synthetic translucent material so the content level can be seen from the outside. Available in 4 sizes, horizontal as well as vertical and suitable for mounting under the side decks, above the waterline. The tanks are supplied with inspection cover and connectors. The hole for the inlet fitting RT..B has already been provided. The inlet fitting should be ordered separately.

Specifications

- Tanks are according to the ISO 8099 standard
- Tank capacities of 6.5 (25), 15.8 (60) or 21.2 (80) gallon (litres)

Connections

- Suction pipe with angled Ø1½" (38 mm) hose connector for deck plate connection
- Angled hose connector Ø1½" (38 mm) for discharge
- Angled hose connector Ø¾" (19 mm), for tank ventilation
- Hole for inlet fitting type RT..B

Type	Suitable for	Capacity (gallon)
WW25WH	Waste water (horizontal version)	6.5
WW25W	Waste water	6.5
WW60W	Waste water	15.8
WW80W	Waste water	21.2



WW25WH



WW..W

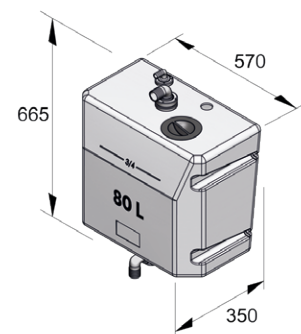
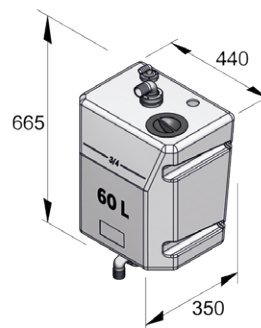
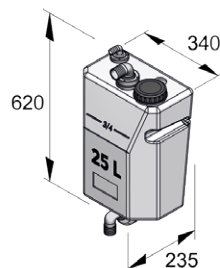
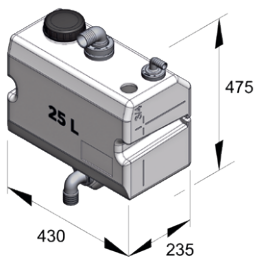

Dimensions: plus or minus 2%
Height dimensions includes connectors

RIGID TANKS FOR WASTE WATER

Complete tank type WWS

Ready to go!

These tanks are made of odour impermeable synthetic translucent material, so the content level can be seen from the outside. These complete tanks come with a VETUS waste water pump (type EMP140, see page 163), inspection cover, ultrasonic level sensor, connectors and 2 securing straps. Only the 12 or 24 Volt level gauge and the inlet fitting (type RT..B) must be ordered separately (see page 164).

All connections go through the top of the tank. Type WWS is suitable for storing black water as well as grey waste water and is especially designed to save installation time.

Specifications

- Suitable for 12 or 24 Volt
- Tanks are according to the ISO 8099 standard
- Tank capacities of 11.1 gal. (42 l.), 16.1 gal. (61 l.), 23.2 gal. (88 l.) or 31.7 gal. (120 l.).

Connections

- Suction pipe with angled hose connector \varnothing 1 1/2" (38 mm) for discharge to onshore holding facility
- Breather connection \varnothing 3/4" (19 mm)
- Pump-out connection \varnothing 1 1/2" (38 mm)
- Hole for inlet fitting type RT..B

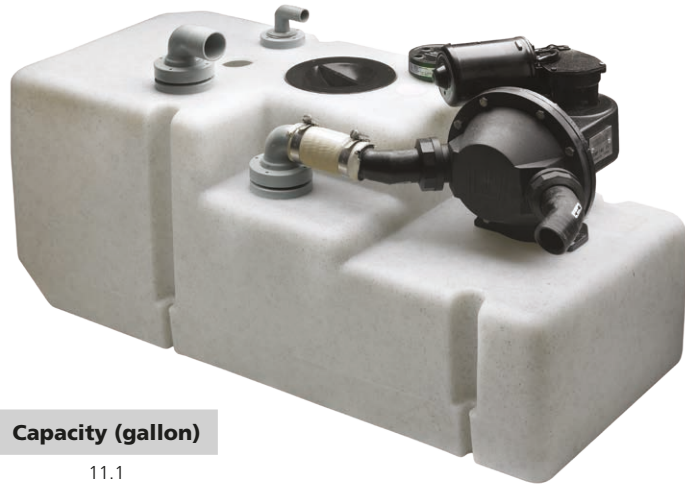

WWS

Type	Suitable for	Capacity (gallon)
WWS4212B	"Black" and "grey" waste water incl. 12 Volt pump	11.1
WWS4224B	"Black" and "grey" waste water incl. 24 Volt pump	11.1
WWS6112B	"Black" and "grey" waste water incl. 12 Volt pump	16.1
WWS6124B	"Black" and "grey" waste water incl. 24 Volt pump	16.1
WWS8812B	"Black" and "grey" waste water incl. 12 Volt pump	23.2
WWS8824B	"Black" and "grey" waste water incl. 24 Volt pump	23.2
WWS12012B	"Black" and "grey" waste water incl. 12 Volt pump	31.7
WWS12024B	"Black" and "grey" waste water incl. 24 Volt pump	31.7

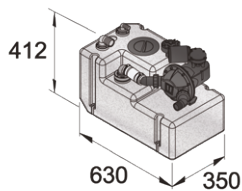

11.1 gallon

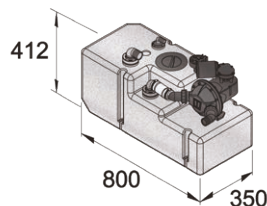

6.1 gallon

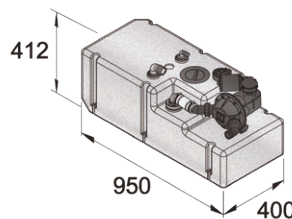

32.2 gallon

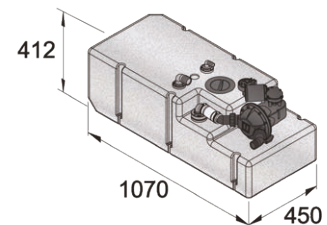

31.7 gallon

Height dimensions includes connectors

APT100 - One tank for all purposes

Fresh water, waste water or diesel: this tank can handle it

A new series of all-purpose tanks is introduced by VETUS: meet the APT100. Made from high-grade polyethylene, this large capacity tank handles almost any liquid you would like to store on your boat. It features an inspection lid and is ready for the appropriate ILT connection kit. On the bottom is a 38 mm connection that can be drilled out for interconnection purpose or draining. The robust appearance and the all-new design make this the tank to have.

For specifications and dimensions see page 140.



APT100



FLEXIBLE TANKS FOR TOILET AND WASTE WATER

VETUS flexible tank type TANKV

Short term waste water storage

These flexible tanks are constructed in the same robust way as the flexible drinking water tanks (see page 141). However, the material used is suitable to store waste water. These tanks should be pumped and flushed after a day's boating. Available in several dimensions and capacities.

A repair kit is available (REPSETOT).

Type	Capacity (appr.) (gallon)	Dimensions (appr.) (inch)	Height filled (appr.) (inch)
TANKV55	14.5	26 ⁴⁹ / ₆₄ x 30 ⁴⁵ / ₆₄ "	9 ²⁷ / ₃₂ "
TANKV70	18.5	30 ⁴⁵ / ₆₄ x 30 ⁴⁵ / ₆₄ "	10 ⁵ / ₈ "
TANKV100	26.4	31 ⁷ / ₆₄ x 39 ³ / ₈ "	10 ⁵ / ₈ "
TANKV160	42.3	31 ⁷ / ₆₄ x 55 ²⁹ / ₃₂ "	10 ⁵ / ₈ "

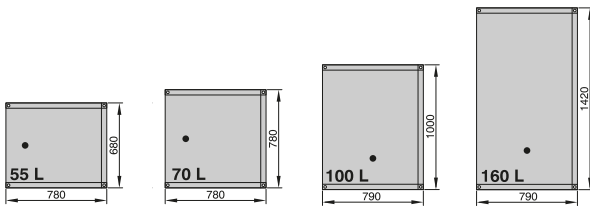

TANKV

- 2 Angled hose connectors $\text{\O} 1\frac{1}{2}$ " (38 mm) (supplied with each tank)
- Angled breather nipple $\text{\O} \frac{5}{8}$ " (16 mm), already fitted
- Breather nipple $\text{\O} \frac{5}{8}$ " (16 mm) (not included)
- Air vent for anti-siphoning, see page 96. When discharge of the tank through a deck plate is required, a $\text{\O} 1\frac{1}{2}$ " (38 mm) tank connector type FT38B is available as an option, see the price-list

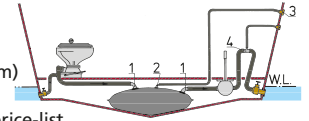

NO-SMELL FILTERS

Filter types NSF and NSFS

Fresh air

Allowing fresh air into a waste tank reduces anaerobic growth and the build up of gas. However, unpleasant odours can also escape through this air breather line. This can be prevented by the installation of a VETUS no-smell filter. The no-smell filter is easy to install and contains activated carbon material to absorb odours. Add the VETUS waste water breather hose made of reinforced PVC for a proper operating system.

Please note

The filter element is replaceable and should be renewed once a year.

Type	Description	L x W x H inches (mm)	Hose \O inches (mm)
NSF16S	Small no-smell filter	4 ¹ / ₄ " (107) x 4 ³ / ₈ " (111) x 4 ³ / ₈ " (111)	⁵ / ₈ (16)
NSF16	Large no-smell filter	5 ⁷ / ₈ " (148) x 5 ¹⁵ / ₁₆ " (150) x 6 ³ / ₈ " (162)	⁵ / ₈ (16)
NSF19	Large no-smell filter	5 ⁷ / ₈ " (148) x 5 ¹⁵ / ₁₆ " (150) x 6 ³ / ₈ " (162)	³ / ₄ (19)
NSF25	Large no-smell filter	5 ⁷ / ₈ " (148) x 5 ¹⁵ / ₁₆ " (150) x 6 ³ / ₈ " (162)	1 (25)
NSF38	Large no-smell filter	5 ⁷ / ₈ " (148) x 5 ¹⁵ / ₁₆ " (150) x 6 ³ / ₈ " (162)	1 ¹ / ₂ (38)



NSF

NSFS

Type	Description
NSF16FES	Spare filter element for small no-smell filters
NSF16FE	Spare filter element for large no-smell filters

No-smell filters element type NSFCAN

Revolutionary dual function

For specifications and dimensions see page 133.

NSFCAN

NSFCANS



TankFresh

Odour-free tank guaranteed

This VETUS product is an organic concentrate of bacteria which cause the faeces in the waste water system to break down without emitting any odour, unlike other chemical products that often only mask the smell. When using just one bottle of TankFresh periodically, your waste water system can function virtually without odour for an entire boating season.

Specifications

- Comes in a convenient 500 ml dosage bottle
- Consists of nature's own ingredients only
- Proven reduction of odours in the tank

Type	Description
TFRESH05	500 ml bottle

TFRESH



ACCESSORIES FOR WASTE WATER TANKS

Ultrasonic level sensor type SENSORA

Easy measurement

This VETUS ultrasonic level sensor is contactless and will easily measure the fluid level in the tank.

Type	Description
SENSORA	Ultrasonic level sensor

SENSORA



For more information and available level sensors see page 109.

Waste water control panel type WWCP

Integrated tank level monitoring

This easy-to-use control panel with security lock can be used manually or automatically to control the full tank pump-out and manage the complete waste water system. The WWCP panel is connected to a VETUS level sensor (type WSENSORA or SENSORA) and indicates the content level in the tank using LED's it will ignore brief maximum level peaks caused by boat movements. A motorised ball valve can also be connected to the panel. In either manual or automatic mode, the valve will open before the pump starts. Once the tank is empty, the pump will switch off and the valve will close automatically. A switched outlet on the panel, connected to a relay in the toilet power supply, makes it possible to prevent the toilet(s) from being flushed if the tank is full.

Specifications

- Panel dimensions 3³/₈" x 3³/₈" (85 x 85 mm)
- Build-in depth 1⁹/₁₆" (40 mm)
- Suitable for 12 or 24 Volt
- Usage in stand-by mode 4mA, electric pump 10A max, remotely controlled ball valve 5A max and external alarm 1A max.
- Valve and level sensor are not included

Type	Description
WWCP	Waste water control panel



WWCP

Vacuum operated vent valve type VRF

Indispensable safety factor

To prevent the possibility of insufficient air entering through the vent line during pump out operations causing the tank to implode, VETUS has developed a valve according to the ISO8099 standard. In case of significantly reduced pressure in the holding tanks, the valve will open automatically to let air into the tank. By using this valve fitting of a large diameter vent line is no longer necessary. The valve is made from synthetic materials and therefore absolutely corrosion-free. Hole size in the tank is 2¹³/₆₄" (56 mm).

Type	Description
VRF56A	Vacuum valve for waste water tank



VRF56A

Waste water / bilge pump type EMP140

360° Rotating hose connections, less installation time

This reliable pump with a capacity of 27 l/min at zero head, is self-priming, provided with 2 duck-bill valves and suitable for pumping grey and black water. It has rotating hose connections so installation time will be reduced.

Specifications

- Weight 14.4 lbs (7kg)
- Max suction height 10 ft. (3 mtr)
- Max delivery height 6 ft. (5 mtr)
- Available in 12 or 24 Volt
- Current at 12 Volt 6A and at 24 Volt 4A

Type	Volt	Hose connection inches (mm)
EMP14012B	12	1 1/2 (38)
EMP14024B	24	1 1/2 (38)

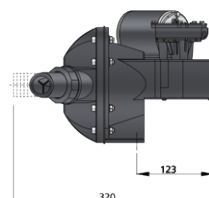
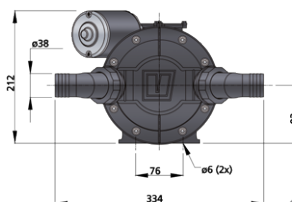

EMP140

ACCESSORIES FOR WASTE WATER TANKS

Angled fittings

Synthetic fittings for VETUS flexible tanks (type FT) or rigid tanks (type RT). Suitable for hoses with an internal diameter of $\frac{1}{2}$ " (13 mm), $\frac{5}{8}$ " (16 mm), $\frac{3}{4}$ " (19 mm), 1" (25 mm) or $1\frac{1}{2}$ " (38 mm).. The required hole size for flexible tank is $\frac{1}{8}$ " (42 mm) and for rigid tanks $\frac{1}{16}$ " (43 mm).



RT



FT

Type	Hose Ø inches (mm)	Angle
RT13B	$\frac{1}{2}$ (13)	right angle
RT16B	$\frac{5}{8}$ (16)	right angle
RT19B	$\frac{3}{4}$ (19)	right angle
RT25B	1 (25)	right angle
RT38B	$1\frac{1}{2}$ (38)	right angle

Type	Hose Ø inches (mm)	Angle
FT13B	$\frac{1}{2}$ (13)	right angle
FT16B	$\frac{5}{8}$ (16)	right angle
FT19B	$\frac{3}{4}$ (19)	right angle
FT25B	1 (25)	right angle
FT38B	$1\frac{1}{2}$ (38)	right angle

Installation kit type BTKIT

Consisting of 1 inspection lid with counter-flange and fastenings, 2 securing straps, and 1 wrench for angled fittings.

Specifications

- Overall diameter $\frac{6}{64}$ " (156 mm)
- Cut out diameter $\frac{4}{32}$ " (115 mm)

Type	Description
BTKIT	Fitting kit for synthetic waste water tanks



BTKIT

Lockable ball valve type BV1½L

This stainless steel (AISI 316) ball valve with G1½ thread is in some countries a legal requirement to prevent the accidental discharge of black water in port. This valve can be padlocked (padlock itself is not supplied).

Type	Description
BV1½L	Stainless steel (AISI 316) ball valve

BV1½L



ACCESSORIES FOR WASTE WATER TANKS

Synthetic hose adapters type HA

These synthetic hose adapters can be cut to the appropriate hose sizes.

Type	Ø Dim. inches (mm)
HA1338	1/2 - 1 1/2 (13 - 38)
HA3060	1 3/16 - 2 23/64 (30 - 60)



HA1338

HA3060

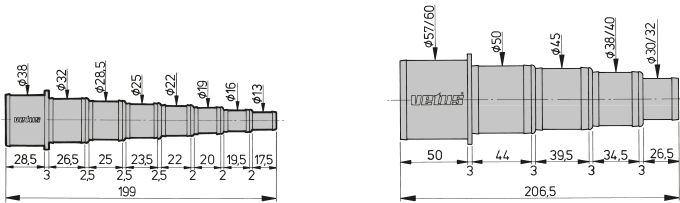

Universal inspection port for tanks type ILT120

Innovative inspection port with robust design

The standard delivery of the VETUS ILT is an innovative port with flange-in-ring design which facilitates easy opening, inspecting and cleaning the tank, even after being closed for a long time. The inspection port has a counter flange and a rubber seal which are inserted into a Ø 6 1/4" (159 mm) hole in the tank. All that needs to be done is tighten the 4 supplied bolts which compresses the rubber seal to ensure perfect sealing.

The "clamp and seal" design simplifies installation, making the drilling of a Ø 6 1/4" (159 mm) hole the hardest part in the installation! The black blind plate can be replaced by various connection kits.



ILT120

Waste water connection kit ILTCONW

Although not mandatory as with fuel tanks, a large inspection port in a waste water tank will facilitate cleaning. Having all the connections at a single point also makes inspection simpler. The VETUS waste water disc is supplied with everything you need for your waste water tank, it doesn't matter if it's a custom made steel, aluminium or a VETUS thick walled rigid tank.

Connections that come with this interchangeable disc are

- Ø 1 1/2" (38 mm) connection for discharge (ability to make this a suction connector by mounting a standard Ø 1 9/16" (40 mm) PVC pipe)
- Ø 1 1/2" (38 mm) inlet connection
- Ø 1" (25 mm) inlet connection
- Ø 3/4" (19 mm) inlet connection
- Ventilation connection Ø 3/4" (19 mm)
- 5 hole SAE flange tank level sensor connection (suitable for SENSORA, SENSORB and WWSENSOR)



ILTCONW

Type	Description	Diameter inches (mm)	Diameter hole inches (mm)
ILT120	Inspection port with counter flange	4 3/4" (120)	6 1/4" (159)
VSAW159	Ø 6 1/4" hole saw for plastic, G.R.P. or metal tanks		6 1/4" (159)



ACCESSORIES FOR WASTE WATER TANKS

Remotely controlled ball valves type MV

Simple manual override

These motorised stainless steel (AISI 316) valves with a powder coated aluminium actuator housing enable any skin fitting/through hull to be electrically opened or closed from a remote location. Also suitable for every type of fuel, ignition protected. The G-threading meets the requirements of ISO 228-1 and 9093-1. The valves can be powered fully opened or closed in approximately 12 to 25 seconds. The powerful motors have a maximum torque of 40 or 220Nm.



MV

Type	MV12A	MV24A	MV24B
Power supply range	11-13 VDC	18-24VDC	20-24VDC
Operating current @ max. torque	1000±10% mA @12VDC	500±10% mA @24VDC	2000±5% mA @24VDC
Static current	50±5 mA	25±5 mA	60±5 mA
Opening and closing	✓		
Max. operation Torque	40Nm		220Nm
Manual over-ride tool	Hex Key		Wrench
Ambient temp.	-4°F (20°C) to +113°F (45°C)		
ISO8846 certified	Yes		

Control panels*	MV12A	MV24A	MV24B
ELVPAN12	✓		-
ELVPAN24			✓
WWCP (page 163)	✓		✓

*Ordered separately



ELVPAN

Type	G inches (ISO 228)	DN inches (mm)	H1 inches (mm)	H2 inches (mm)	L inches (mm)	Weight lbs (kg)
MV12A1/2	1/2	19/32 (15)	57/64 (22.5)	1 31/32 (42)	2 53/64 (72)	4.2 (2.2)
MV12A3/4	3/4	5/32 (20)	57/64 (22.5)	1 57/64 (48)	3 5/32 (80)	4.6 (2.4)
MV12A1	1	1 (25)	1 3/16 (30)	2 11/64 (55)	3 11/32 (85)	5.5 (2.8)
MV12A1 1/4	1 1/4	1 7/64 (32)	1 7/16 (36.5)	2 23/64 (60)	4 9/64 (105)	6.8 (3.4)
MV12A1 1/2	1 1/2	38	1 9/19 (40)	2 3/4 (70)	4 29/64 (113)	8.3 (4.2)
MV24B2	2	50	1 13/16 (46.5)	3 11/32 (85)	5 13/64 (132)	16.3 (7.8)

MV..A

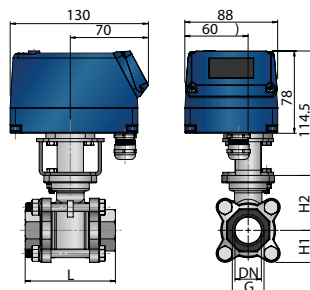

MV..B

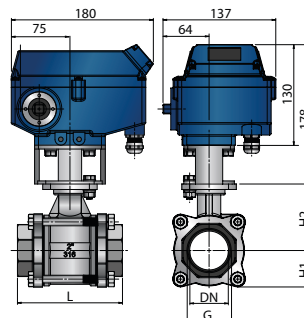

ACCESSORIES FOR WASTE WATER TANKS

Extraction pipes type WTS for rigid waste water tanks

These extraction pipes are for both grey and black water tanks. They can be used for electrical or manually operated diaphragm pumps, or for direct connection to deck plate.

With the choice between angled or straight connections of \varnothing 1 1/2" (38 mm) and with a tube length of 30 11/16" (780 mm) (can be cut to size).

Type	Length inches (mm)	Hose nipple \varnothing inches (mm)	Angle
WTS780385	30 11/16 (780)	1 1/2" (38 mm)	straight
WTS78038B	30 11/16 (780)	1 1/2" (38 mm)	right angle



WTS

Waste water hose type WWHOSEA



WWHOSEA

Impermeable sanitary no-smell hoses type SAHOSE



SAHOSE

For a complete overview of hoses see page 404.

Anti-siphoning air vent

For more information and available types see page 96.



ASD38H

Inspection lid type WTK02

For (waste) water tanks only!

Specifications

- Overall diameter 6 9/64" (156 mm)
- Cut out diameter 4 17/32" (115 mm)
- Not suitable for fuel tanks
- Ideal for metal tanks

Type	Description
WTK02	Inspection lid only, for rigid drinking water tanks



WTK02



ACCESSORIES FOR WASTE WATER TANKS

The waste water connector line-up consists of a three-way valve, a Y connector, a non-return valve and the additional hose connectors. These hose connectors are fully rotatable and are ordered separately to fit your existing hoses. Made entirely from high grade nylon, these products are strong and durable. With connectors variations from 19 mm up to 38 mm, it's plug-and-play on every boat.

This line-up allows you to professionally connect or expand your waste water system. With the three-way valve and the Y connector you can have as many connections as you like, while the duck bill valve keeps contaminated water from flowing back. Hose connectors are sold per piece or per two, so you can mix and match to your needs. The three-way valve can be padlocked in one position (e.g. when harbours want to ensure waste water is directed to the tank instead of discharged overboard). Both the three-way valve and the Y-connector come equipped with a bracket for easy mounting on wall or floor.

Plastic three-way valve

(without hose connections)

Rotatable hose connections should be ordered separately (5 different sizes available).



Type	Description
Y3V	Plastic three-way valve

Y3V

Plastic Y-connector

(without hose connections)

Rotatable hose connections should be ordered separately (5 different sizes available).



Type	Description
Y3C	Plastic Y-connector

Y3C

Plastic in-line non-return valve

(without hose connections)

Rotatable hose connections should be ordered separately (5 different sizes available).



Type	Description
YNRE	Plastic in-line non-return valve (duck bill)

YNRE

Plastic hose connections for Y3V, Y3C and YNRE

Type	Description
YPA38P2	Hose connector 1½ inch (38 mm) (2pcs.)
YPA38P1	Hose connector 1½ inch (38 mm) (1pcs.)
YPA32P2	Hose connector 1¼ inch (32 mm) (2pcs.)
YPA32P1	Hose connector 1¼ inch (32 mm) (1pcs.)
YPA28P2	Hose connector 1⅜ inch (28 mm) (2pcs.)
YPA28P1	Hose connector 1⅜ inch (28 mm) (1pcs.)
YPA25P2	Hose connector 1 inch (25 mm) (2pcs.)
YPA25P1	Hose connector 1 inch (25 mm) (1pcs.)
YPA19P2	Hose connector ¾ inch (19 mm) (2pcs.)
YPA19P1	Hose connector ¾ inch (19 mm) (1pcs.)



YPA

MANEUVERING SYSTEMS

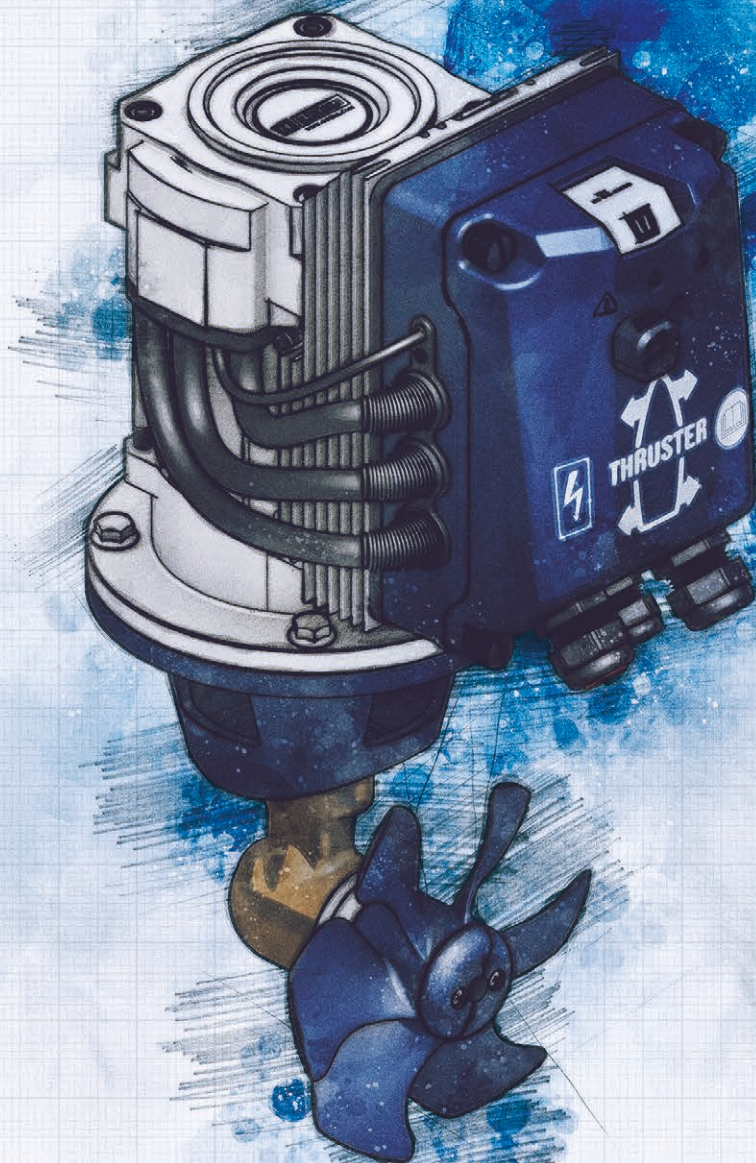

DOCKING

Thrusters can take the stress out of docking by giving you sideways control of the movement and position of the bow and the stern of your boat. They work by rotating a propeller (at very high speed and power) in a submerged tube or a housing mounted athwartships (across the boat), and located near the bow and/or the stern.

A simple control panel (usually a joystick) allows you to push the bow and/or stern sideways, to resist the force of a crosswind and cross current, while you are docking or maneuvering in close quarters (getting in or out of the marina).

What thrusters will do for you and your boat

- Allow you to maintain control while docking and manoeuvring, even into a very tight slip in a crowded marina
- Allow a single crew member to pick up and secure the dock lines while you move the boat sideways from one piling or mooring buoy to the next - slowly, carefully, quietly and with very little pushing, pulling or shouting.
- Allow you and your one-person crew to handle and control a much bigger and more comfortable boat
- Avoid the possibility of hitting another boat, a dock or a piling, that might cause expensive damage to your boat, another boat or the marina facilities
- Minimize the risk of a crew member being injured during docking manoeuvres in difficult conditions
- Allow you to handle your boat with the same expertise, grace and panache as the other captains whose boats are equipped with VETUS thrusters
- Make boating more fun

VETUS offers a solution for each and every boat. From small to big boats, with a shallow or deep draft, slow or fast, electrically or hydraulically driven. New products are continuously introduced and existing products are frequently updated, so please go to www.vetus.com for the latest developments.

HOW TO CHOOSE THE CORRECT BOW AND STERN THRUSTER

After you have selected your type of thruster, the following tool can be used to calculate the required thrust force or you can use the table below to select your ideal thruster.

The influence of the wind

The force applied to the boat by the wind is determined by the wind speed, the wind angle and the lateral wind draft area of the boat. If the wind blows at right angles to the boat, this wind pressure is most difficult to counter. However, this is seldom the case and as most boat superstructures are fairly streamlined, a reduction factor of 0.75 is generally applied, when calculating the wind pressure.

The turning moment

The turning moment is calculated by multiplying the wind force by the distance (A) between the centre of effort of the wind and the point of rotation of the boat. In order to simplify this somewhat: for the vast majority of boats a rule of thumb may be applied that the turning moment is calculated by multiplying the wind force by half of the boat's overall length.

The thrust force

It is the thrust force which is the true measure of a bow thruster's usefulness and not the output of the electric or hydraulic motor in kW or HP. The nominal thrust force is a combination of the motor power, the shape of the propeller and the efficiency losses inside the tunnel. VETUS electrical bow thrusters have a very high thrust of between 17 and 23 kgf per kW motor power. The required thrust force to counter the effects of the wind is now calculated by dividing the turning moment by the distance (B) between the centre of the bow thruster tunnel and the pivot point of the boat.

Note

The further forward the tunnel can be positioned, the greater effect the thruster will have.

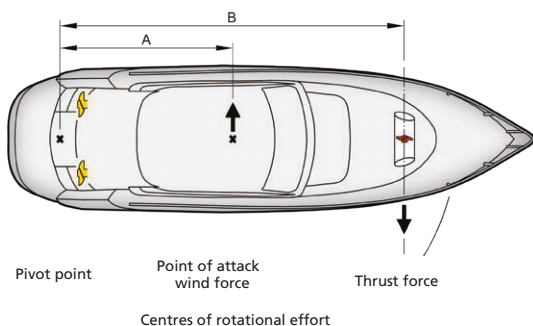

Wind force Beaufort	Description	Wind speed m/s (ft/s)	Wind pressure N/m ² - (kgf/m ²)
4	moderate breeze	5,5 to 7,9 (17 - 27)	20 to 40 - (2,0 to 4,1)
5	fresh breeze	8,0 to 10,7 (27 - 37)	41 to 74 - (4,2 to 7,5)
6	strong breeze	10,8 to 13,8 (37 - 47)	75 to 123 - (7,7 to 12,5)
7	near gale	13,9 to 17,1 (47 - 57)	125 to 189 - (12,7 to 19,2)
8	gale	17,2 to 20,7 (57 - 67)	191 to 276 - (19,4 to 28,2)

Calculation example

The boat has an overall length of 36 ft. (11 metre) and the lateral wind draft measures 194 ft.² (18 m²). It is required that the bow can be controlled easily when wind force Beaufort 5 applies.

At wind force Beaufort 5, the wind pressure is: Rho= 41 to 74 N/m², i.e. Rho (average) = 60 N/m².

The required torque is

T = wind pressure x wind draft x reduction factor x distance centre of effort to pivot point, (=approx. half the ship's length)

T = 60 N/m² x 18 m² x 0,75 x (11 x 0,5) m = 4455 Nm

The required thrust force is calculated as follows

$$F = \frac{\text{torque}}{\text{distance between centre of bow thruster and the pivot point of the boat (with the transom as pivot of the boat)}} = \frac{4455 \text{ Nm}}{10,5 \text{ m}} = 420 \text{ N (42 kgf)}$$

The most suitable VETUS bow thruster is for this particular vessel is the 99 lbf (45 kgf) (55 lbf (25 kgf) in the case of Beaufort 4 and 156 lbf (75 kgf) in the case of Beaufort 6). Always bear in mind that the effective performance of a bow thruster will vary with each particular boat, as the displacement, the shape of the underwater section and the positioning of the bow thruster will always remain variable factors.

As a rule of thumb it can be assumed that the stern thruster may be "one model smaller" than the bow thruster model, as it has been calculated. Therefore, in this case a stern thruster type 77 lbf (35 kgf) will be the correct model. Below is a selection table of bow thruster models against recommended boat length. Please note that this table is given for general guidance only and the calculation shown above should be used whenever possible. If you are in any doubt about the best thruster for your boat, your VETUS support representative will be glad to help you with the decision.

Selection table thrust force - boat length

	6	8	10	12	14	16	18	20	22	24	26	28	30	32	34	43
Metre:	6	8	10	12	14	16	18	20	22	24	26	28	30	32	34	43
Feet:	20	26	33	39	46	52	59	66	72	79	85	92	98	105	112	141
25 kgf	■																
35 kgf		■															
45 kgf			■														
55 kgf**				■													
60 kgf					■												
75 kgf						■											
95 kgf**							■										
125 kgf								■									
160 kgf**									■								
220 kgf										■							
230 kgf*											■						
285 kgf												■					
310 kgf*													■				
410 kgf*														■			
550 kgf*															■		

* only available as hydraulically driven bow thruster
 ** available as hydraulically and electrical driven bow thruster

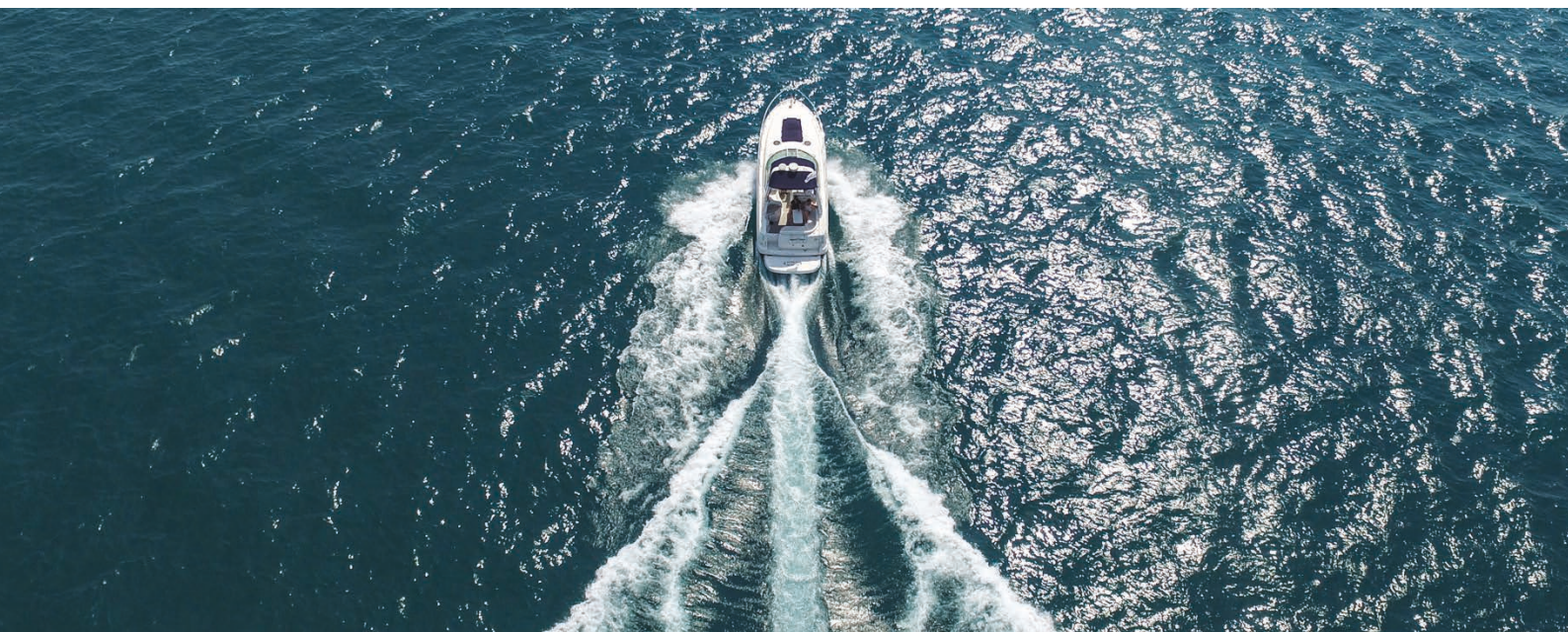

The world of VETUS thrusters - a continuum of power outputs, sizes

DC BOW AND STERN THRUSTERS



The original recreational boat thruster, developed and refined over 30 years of hard work on boats ranging from 15 to 90 feet.

- On-off, port-starboard controls.
- Simple and intuitive to operate
- Lowest cost, simplest installation, easy retrofit
- A range of eleven thrusters, with thrust outputs ranging from 25 kgf to 285 kgf
- Battery powered at 12, 24 and 48 Volts
- Run time: 2-4 minutes continuous or combined in one hour
- Motor technology: direct current, series wound with carbon brushes

Turn to page 175 for detailed information

Suitable for:
boats 4,5 to 27 meter

BOW PRO DC-AC INDUCTION BOW AND STERN THRUSTERS



The leading edge of thruster development, but utilizing well proven components and technology. For boats ranging from 18 to 50 feet.

- Resistant to damage from misuse and overuse, with heat sensing and self-regulating electronics
- Proportional joysticks allow you to vary the effective power output of the thruster for more boat control.
- Simple and intuitive to operate, with a small self learning curve on adjusting the thrust
- The same installation process as a standard VETUS DC thruster, but with some simple and well documented panel set-up procedures
- A range of 18 thrusters, with power outputs from 30 kgf to 130 kgf
- Battery powered at 12 and 24 Volts
- Run time: 10 minutes (minimum) at full power with longer runtimes at reduced power, ultimately limited by battery capacity and recharge rate
- Motor technology: efficient, sealed, induction motors (with no carbon brushes) giving maximum run time on a charged battery bank

Turn to page 178 for detailed information.

Suitable for:
boats 5,5 to 15 meter

RIMDRIVE DC INDUCTION THRUSTERS



If you treasure peace, perfect peace, on gentle waters, or need to move with stealth on troubled waters, the world's quietest thrusters are for you. For boats ranging from 40 to 60 feet.

- Proportional joysticks allow you to vary the effective power output of the thruster for more boat control.
- Resistant to damage from misuse and overuse, with heat sensing and self-regulating electronics
- Simple and intuitive to operate, with a small learning curve on adjusting the thrust
- A slightly different installation process from a standard VETUS DC thruster, but no new skills required.
- A range of two thrusters with power outputs of 125 kgf and 160 kgf
- Battery powered at 48 Volts
- Runtime: 10 minutes minimum at full power with longer runtime at reduced power, on minimum recommended battery bank, but easily extended by increasing battery capacity

Turn to page 180 for detailed information.

Suitable for:
boats 12 to 18 meter

and capabilities. The right thrusters for every boat and every situation.

**EXTENDED RUNTIME
DC BOW AND STERN
THRUSTERS**



An extension of the basic, time-tested DC thruster, developed for use in integrated boat control systems requiring long runtimes at high power outputs. For boats ranging from 36 to 75 feet.

- On-off, port-starboard controls
- Simple and intuitive to operate
- Simple installation, easy retrofit
- 5 models with power outputs ranging from 95 kgf to 220 kgf
- Battery powered at 12 and 24 Volts
- Run time 7-10 minutes continuous or combined in one hour.
- Motor technology: direct current, series wound with carbon brushes

Turn to page 182 for detailed information

Suitable for:
boats 11 to 23 meter

**IGNITION PROTECTED
DC BOW AND STERN
THRUSTERS**



An extension of the basic, time-tested DC thruster, but the only electric thruster type suitable for use in compartments containing gasoline / petrol engines, tanks and fuel lines, propane tanks and lines, jet skis/pwcs or outboard engines and their fuel tanks, as the motor is encased to prevent explosive fumes reaching its interior. For boats ranging from 16 to 60 feet.

- On-off, port-starboard controls
- Simple and intuitive to operate
- Simple installation (regular + encasement), easy retrofit
- 10 models with power outputs ranging from 25 kgf to 155 kgf
- Battery powered at 12 and 24 Volts
- Run times 2-4 minutes continuous or combined in one hour
- Motor technology: direct current, series wound with carbon brushes

Turn to page 183 for detailed information

Suitable for:
boats 5 to 18 meter

**RETRACTABLE
DC BOW AND STERN
THRUSTERS**



The thruster to select when your boat's shallow draft does not allow a conventional bow tunnel or stern tube to be adequately submerged. A VETUS DC thruster mounted on a swing mechanism that extends below the boat prior to operation and retracts back into the hull after use. For boats ranging from 25 to 60 feet.

- On-off, port-starboard controls with automatic deployment and retraction
- Simple and intuitive to operate
- A unique installation process requiring careful measurement, cutting and fitting in accordance with the detailed instructions provided
- 6 models with power outputs ranging from 55 kgf to 160 kgf
- Battery powered at 12 and 24 Volts
- Run times 2-4 minutes continuous or combined in one hour
- Motor technology: direct current, series wound with carbon brushes

Turn to page 184 for detailed information

Suitable for:
boats 8 to 18 meter

**HYDRAULIC
THRUSTERS**

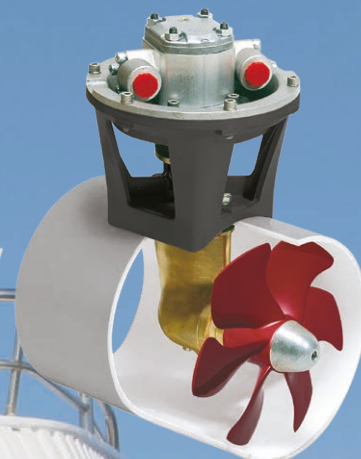

Thrust whenever you need it, for as long as you need it -, is the defining characteristic of these powerful machines and their systems. Built with industrial grade components and ideal for commercial and recreational heavy-duty applications. For vessels ranging from 35 to 120 feet.

- Controls can be on-off/ port-starboard, two stage with half-power hold déteintes, proportional or a computer managing station-holding or integrated boat-control
- Made for very hard work - long lived, reliable, accustomed to abuse and highly resistant to damage
- Specialist installation required due to complex components
- 7 models with power outputs ranging from 55 kgf to 550 kgf
- Powered by a prime mover engine(s)
- Continuous runtime
- Motor technology: hydraulic

Turn to page 186 for detailed information

Suitable for:
boats 11 to 37 meter

The world of VETUS thrusters

Specifications	DC THRUSTERS	BOW PRO DC-AC THRUSTERS	RIMDRIVE DC THRUSTERS	HYDRAULIC THRUSTERS	EXTENDED RUNTIME DC THRUSTERS	IGNITION PROTECTED DC THRUSTERS	RETRACTABLE DC THRUSTERS
Sound	++	+++	++++	+++	++	++	++
Energy use	++	+++	+++	++++	++	++	++
Proportional	No	Yes	Yes	Yes	No	No	No
Maintenance	carbon brushes + anode + power circuit check	anode + power circuit check	anode + power circuit check	anode + hydraulic lines check	carbon brushes + anode + power circuit check	carbon brushes + anode + power circuit check	carbon brushes + anode + power circuit check

GLOBAL OVERVIEW PER TYPE

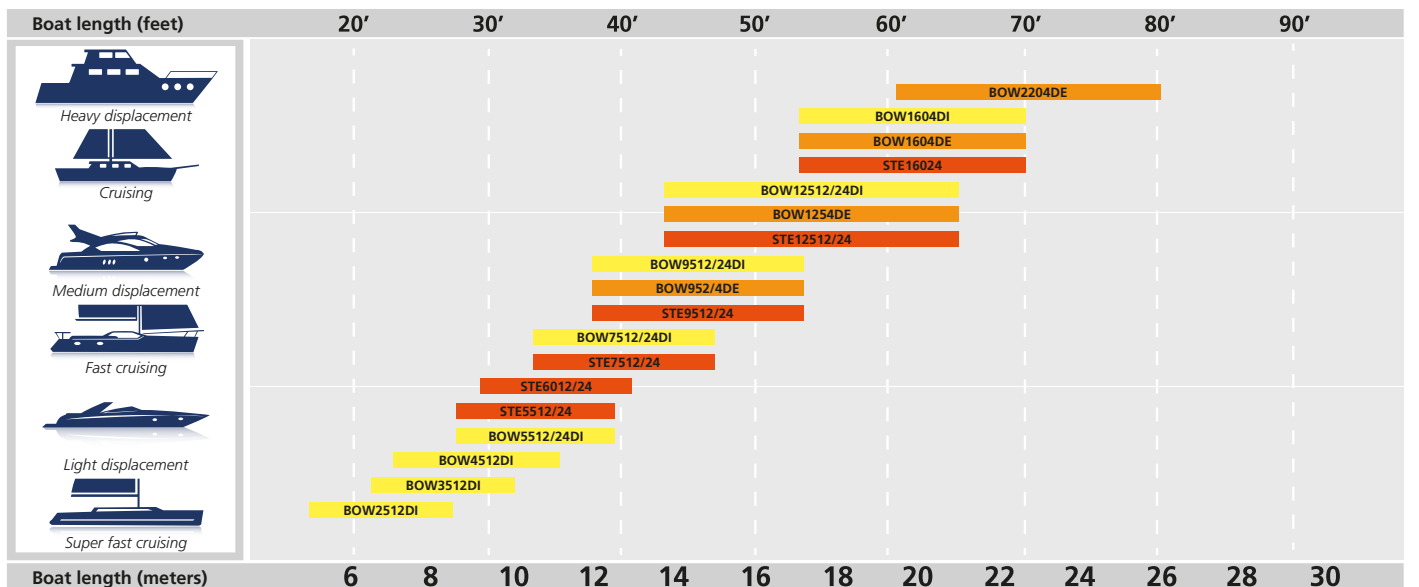
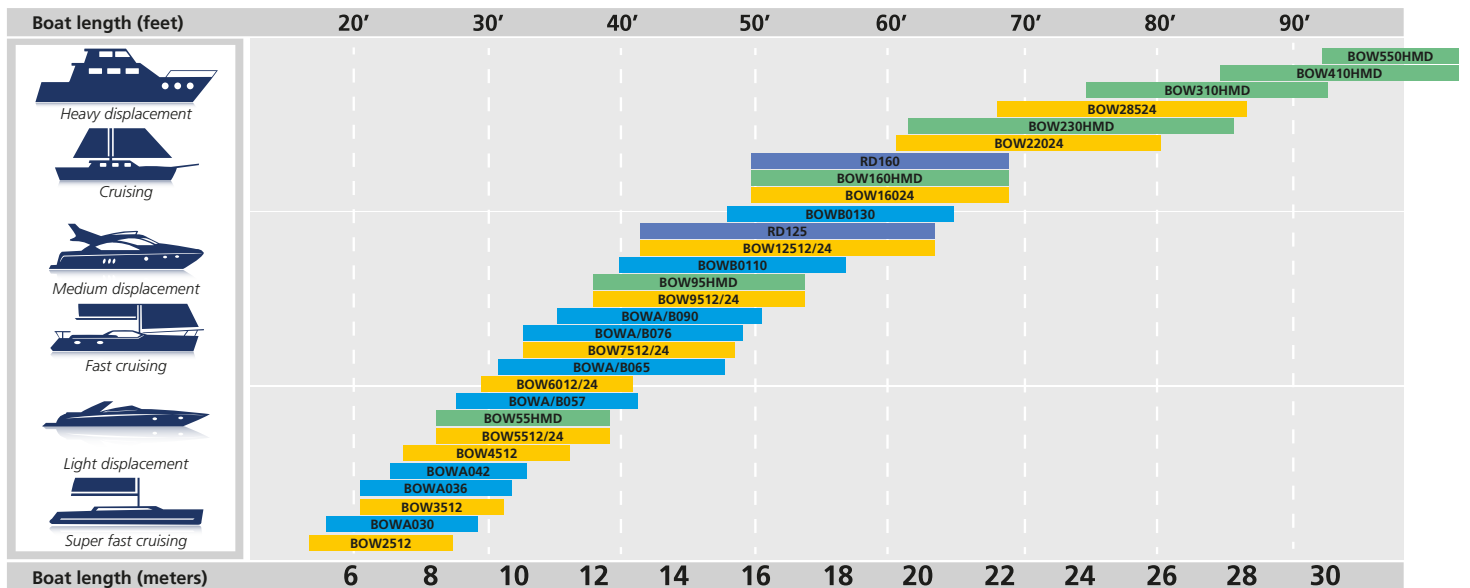

DC THRUSTERS
EXTENDED RUNTIME DC THRUSTERS
BOW PRO DC-AC THRUSTERS
RIMDRIVE THRUSTERS
IGNITION PROTECTED DC THRUSTERS
RETRACTABLE DC THRUSTERS
HYDRAULIC THRUSTERS

DC BOW AND STERN THRUSTERS

The advantages of VETUS bow thrusters are endless, however below we highlight the most important characteristics.

Advantages

- Minimal noise because of the unique propeller blade design, the spiral gears and the flexible coupling
- Optimum flow due to the streamlined tail piece
- The synthetic propeller eliminates corrosion and reduces weight
- The high quality aluminium control panels are interchangeable with older panels
- Easy installation and clear instructions

Type BOW....E, BOW....F and BOW....D

Minimal noise, optimum flow

The original recreational boat thruster, developed and refined over 30 years of hard work on boats ranging from 15 to 90 feet.

- On-off, port-starboard controls.
- Simple and intuitive to operate
- Lowest cost, simplest installation, easy retrofit
- A range of eleven thrusters, with thrust outputs ranging from 25 kgf to 285 kgf
- Battery powered at 12, 24 and 48 Volts
- Run time: 2-4 minutes continuous or combined in one hour
- Motor technology: direct current, series wound with carbon brushes



Bow thruster panels

VETUS has different bow thruster panels available in both deluxe or compact versions. All these panels can be easily fitted in a 2³/₆₄" (52 mm) diameter cut-out and are waterproof to IP65. Every panel is provided with a switched outlet (max. 3A) to connect extra equipment. For more information on control panels for bow and stern thrusters, please see page 188.



BPSR



BPAS



BPAJ



DC BOW AND STERN THRUSTERS



Specifications	BOW2512E	BOW3512E	BOW3512F	BOW4512D	BOW5512D	BOW5524D
Thrust, N (kgf) (effective power output)	250 (25)	350 (35)	350 (35)	450 (45)	550 (55)	600 (60)
Power kW (hp)	1,5 (2)	1,5 (2)	1,5 (2)	3 (4)	3 (4)	3 (4)
Motor, reversible D.C.	✓	✓	✓	✓	✓	✓
Tunnel diameter, internal, inches	4 ²¹ / ₆₄	5 ²⁹ / ₃₂	4 ⁵⁹ / ₆₄	4 ⁵⁹ / ₆₄	5 ²⁹ / ₃₂	7 ⁹ / ₃₂
Weight excluding tunnel, in lbs	22	26	26	44	44	44
Voltage, 12 Volt D.C.	12 V D.C.	12 V D.C.	12 V D.C.	12 V D.C.	12 V D.C.	
Current consumption, Amps.	200	205	205	300	350	
Operating time - continuously, in minutes	4	4	4	4	4	
- maximum per hour, in minutes	4	4	4	4	4	
Main fuse, "slow blow", Amps.	125*	160*	160*	250	250	
Batteries 12 Volt D.C., min. Ah / max. Ah	1x55 / 1x70	1x55 / 1x105	1x55 / 1x105	1x105 / 1x200	1x105 / 1x200	
Battery cables**, total length of positive and negative cables together, m / mm ²	0 - 8 / 25 8-12 / 35	0-11 / 35	0-11 / 35	0-12 / 70	0-12 / 70	
Battery main switch: model BATSW / type BPMAIN	250 / 12	250 / 12	250 / 12	250 / 12	250 / 12	
Voltage, 24 Volt D.C.						24 V D.C.
Current consumption, Amps.						200
Operating time - continuously, in minutes						4
- maximum per hour, in minutes						4
Main fuse, "slow blow", Amps.						125
Batteries 12 Volt D.C., min. Ah / max. Ah						2x55 / 2x70
Battery cables**, total length of positive and negative cables together, m/mm ²						0-23 / 35
Battery main switch, model BATSW / type BPMAIN						250 / 24
Voltage, 48 Volt D.C.						
Current consumption, Amps.						
Operating time - continuously, in minutes						
- maximum per hour, in minutes						
Main fuse, "slow blow", Amps.						
Batteries 12 Volt D.C., min. Ah / max. Ah						
Battery cables**, total length of positive and negative cables together, m/mm ²						
Battery main switch, model BATSW / type BPMAIN						

* This fuse is standard supply

** Based on VETUS battery cable

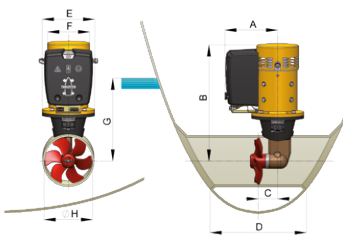

Model number (dim. inch (mm))	BOW2512E	BOW3512E	BOW3512F	BOW4512D	BOW5512D	BOW5524D
A	5 ⁷ / ₁₆	5 ⁷ / ₁₆	5 ⁷ / ₁₆	5 ⁵ / ₈	5 ⁵ / ₈	5 ⁵ / ₈
B	11 ¹¹ / ₁₆	12 ²³ / ₆₄	12 ²³ / ₆₄	14 ³ / ₈	14 ²⁷ / ₃₂	14 ²⁷ / ₃₂
C	2 ⁷ / ₈	3 ⁷ / ₆₄	3 ⁷ / ₆₄	3 ⁷ / ₆₄	3 ⁷ / ₆₄	3 ⁷ / ₆₄
D min./max.	8 ²¹ / ₃₂ / 17 ²¹ / ₆₄	11 ¹³ / ₁₆ / 23 ⁵ / ₈	11 ¹³ / ₁₆ / 23 ⁵ / ₈	9 ²⁷ / ₃₂ / 19 ¹¹ / ₁₆	11 ¹³ / ₁₆ / 23 ⁵ / ₈	11 ¹³ / ₁₆ / 23 ⁵ / ₈
E	5 ⁵⁵ / ₆₄	5 ⁵⁵ / ₆₄	5 ⁵⁵ / ₆₄	6 ¹⁹ / ₆₄	6 ¹⁹ / ₆₄	6 ¹⁹ / ₆₄
F Ø	4 ¹³ / ₃₂	4 ¹³ / ₃₂	4 ¹³ / ₃₂	5 ¹ / ₈	5 ¹ / ₈	5 ¹ / ₈
G min.	4 ²¹ / ₆₄	5 ²⁹ / ₃₂	4 ⁵⁹ / ₆₄	4 ⁵⁹ / ₆₄	5 ²⁹ / ₃₂	5 ²⁹ / ₃₂
H Ø	4 ²¹ / ₆₄	5 ²⁹ / ₃₂	4 ⁵⁹ / ₆₄	4 ⁵⁹ / ₆₄	5 ²⁹ / ₃₂	5 ²⁹ / ₃₂

DC BOW AND STERN THRUSTERS



	BOW6012D BOW6024D	BOW7512D BOW7524D	BOW9512D BOW9524D	BOW12512D BOW12524D	BOW16024D	BOW22024D	BOW28548D
N (kgf)	650 (65) - 12 V 700 (70) - 24 V	800 (80) 12 V 850 (85) 24 V	950 (95) 12 V 1050 (105) 24 V	1250 (125) 12 V 1400 (140) 24 V	1600 (160) 24 V	2200 (220) 24 V	2850 (285) 48 V
kW (hp)	3 (4)	4,4 (6)	5,7 (8)	5,7 (8)	7 (9,5)	11 (15)	17,5 (23,5)
rev. D.C	✓	✓	✓	✓	✓	✓	✓
Ø inch	7 ⁹ / ₃₂	7 ⁹ / ₃₂	7 ⁹ / ₃₂	9 ²⁷ / ₃₂	9 ²⁷ / ₃₂	11 ¹³ / ₁₆	11 ¹³ / ₁₆
lbs	48	57	66	82	82	149	149
Volt	12 V D.C.	12 V D.C.	12 V D.C.	12 V D.C.			
Amps.	280	500	610	800			
Min.	5	2	3	3			
Min.	5	2	3	3			
Fuse	200	355	425	500			
Batt.	1x105 / 1x145	1x120 / 1x225	1x165 / 2x145	1x220 / 2x200			
Cables (neg.)	0-11 / 50 11-16 / 70	0 - 8 / 70 8 - 11 / 95	0 - 10 / 95 10 - 12 / 120	0 - 9 / 120 9 - 12 / 150			
Switch	250 / 12	250 / 12	600 / 12	600 / 12			
Volt	24 V D.C.	24 V D.C.	24 V D.C.	24 V D.C.	24 V D.C.	24 V D.C.	
Amps.	140	280	320	450	540	760	
Min.	5	3	3,5	2,5	4,5	2,5	
Min.	5	3	3,5	2,5	4,5	2,5	
Fuse	100	200	200	300	355	500	
Batt.	2x55 / 2x70	2x70 / 2x145	2x105 / 2x145	2x145 / 2x165	2x165 / 4x165	2x200 / 4x165	
Cables (neg.)	0-20 / 25	0 - 21 / 50	0 - 21 / 50	0 - 20 / 70	0 - 29 / 120	0-12 / 120	
Switch	250 / 24	250 / 24	250 / 24	250 / 24	600 / 24	600 / 24	
Volt							48 V D.C.
Amps.							560
Min.							2,5
Min.							2,5
Fuse							355
Batt.							4x145 / 8x120
Cables (neg.)							0-23 / 95
Switch							600

(dim. in inch in mm)	BOW6012D BOW6024D	BOW7512D BOW7524D	BOW9512D BOW9524D	BOW12512D BOW12524D	BOW16024D	BOW22024D	BOW28548D
A	5 ⁴¹ / ₆₄	9 ³ / ₈	9 ³ / ₈	5 ²³ / ₆₄	8 ⁴⁷ / ₆₄	9 ²³ / ₃₂	9 ²³ / ₃₂
B	15 ⁵ / ₈	18 ⁷ / ₆₄	18 ⁷ / ₆₄	12 ⁵³ / ₆₄	21 ³⁷ / ₆₄	24 ¹¹ / ₁₆	24 ¹¹ / ₁₆
C	3 ¹ / ₃₂	3 ¹ / ₃₂	3 ¹ / ₃₂	2 ⁷ / ₈	4 ¹ / ₄	5 ²³ / ₆₄	5 ²³ / ₆₄
D m/m	14 ⁹ / ₁₆ / 29 ¹ / ₈	14 ⁹ / ₁₆ / 29 ¹ / ₈	14 ⁹ / ₁₆ / 18 ¹ / ₂	8 ²¹ / ₃₂ / 39 ³ / ₈	19 ¹¹ / ₁₆ / 39 ³ / ₈	23 ³ / ₈ / 47 ¹ / ₄	23 ³ / ₈ / 47 ¹ / ₄
E	6 ¹⁹ / ₆₄	11 ²¹ / ₃₂	11 ²¹ / ₃₂	7 ¹ / ₈	9 ²⁹ / ₆₄	10 ⁵ / ₃₂	10 ⁵ / ₃₂
F Ø	5 ¹ / ₈	9 ²⁹ / ₆₄	9 ²⁹ / ₆₄	6 ³ / ₁₆	7 ⁹ / ₃₂	8 ¹¹ / ₃₂	8 ¹¹ / ₃₂
G min.	7 ⁹ / ₃₂	7 ⁹ / ₃₂	7 ⁹ / ₃₂	4 ²¹ / ₆₄	9 ²⁷ / ₃₂	11 ¹³ / ₁₆	11 ¹³ / ₁₆
H Ø	7 ⁹ / ₃₂	7 ⁹ / ₃₂	7 ⁹ / ₃₂	4 ²¹ / ₆₄	9 ²⁷ / ₃₂	11 ¹³ / ₁₆	11 ¹³ / ₁₆



BOW PRO DC-AC INDUCTION BOW AND STERN THRUSTERS

BOW PRO thruster series (BOWA)

Revolutional concept matched with proven technology

Our BOW PRO thrusters use proven induction motors without carbon brushes. As a result, the bow / stern thruster motor is maintenance-free and has Endurance Rated* run-time! Just the tailpiece and the power circuits need regular maintenance. The induction motor is controlled by the VETUS MCV motor controller. The built-in over-temp and low battery protection, combined with the brushless induction motor make the BOW PRO thruster series highly resistant to abuse and ideal for the most demanding boater in the most difficult maneuvering situations!



The BOW PRO thruster is controlled by proprietary CANBUS protocol (digital control). There are two fully-proportional panels available for the BOW PRO thruster series; one basic panel (BPPPA) and one panel with lock-and-hold function for easy docking (BPPJA). BOW PRO thrusters utilize the same propellers and gearboxes proven in VETUS thrusters for over 30 years. Upgrading a boat with an existing thruster to a BOW PRO thruster is easily accommodated as the BOW PRO thruster was made to share tunnel sizes with current VETUS thrusters as well as many other brands. For boats with electric propulsion, VETUS offers the 48 V series pictured right. The BOW PRO range continues to expand. New models with higher outputs for 12, 24 and 48 Volt power supplies will be available soon. For the latest update on this thruster range, please contact your VETUS dealer or check our website.

Specifications

- Precision proportional control
- Endurance Rated Run-time - Limited by the size of your battery bank.
- Maintenance-free brushless motor
- Built-in over-temp and low battery protection
- Highly resistant to abuse
- The thruster(s) and their control panels are connected by cables carrying digital V-CAN signals (VETUS canbus type allowing future integration into boat-wide electronic systems and information displays
- Electronic switching eliminates mechanical solenoids for improved reliability

VETUS strongly advises the use of original V-CAN connection cables to ensure an optimal connection between controls and thruster.

Dimensions of all BOW PROs (in mm)

SERIES	BOWA	BOWA	BOW PRO	BOWA BOWB	BOWA BOWB	BOWA BOWB	BOWA BOWB	BOWB	BOWB
Output	30 kgf	36 kgf	42 kgf	55/57 kgf	65 kgf	76 kgf	90 kgf	110 kgf	130 kgf
A	8 17/64"	8 17/64"	8 17/64"	8 17/64"	8 17/64"	8 17/64"	11 7/64"	11 7/64"	11 7/64"
B	13 25/32"	14 3/32"	14 7/8"	15 15/32"	16 17/64"	16 17/64"	17 51/64"	17 51/64"	17 51/64"
E Ø	7 7/8"	7 7/8"	7 7/8"	7 7/8"	7 7/8"	7 7/8"	7 7/8"	7 7/8"	7 7/8"
F Ø	4 21/64"	4 59/64"	4 59/64"	5 29/32"	7 9/32"	7 9/32"	7 9/32"	7 9/32"	7 9/32"

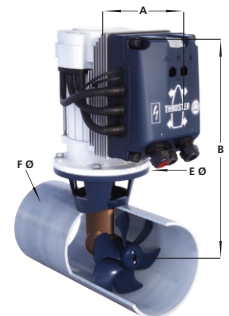

Specifications	BOW PRO 301	BOW PRO 361	BOW PRO 421	BOW PRO 551	BOW PRO 572	BOW PRO 651	BOW PRO 761	BOW PRO 762	BOW PRO 902	>
Product code	BOWA0301	BOWA0361	BOWA0421	BOWA0551	BOWA0572	BOWA0651	BOWA0761	BOWA0762	BOWA0902	
Thrust in N (kgf) (power output)	300 (30)	360 (36)	420 (42)	550 (55)	570 (57)	650 (65)	760 (76)	760 (76)	900 (90)	
Power kW	1,6	1,6	3,1	3,1	3,1	3,1	3,1	3,1	5,7	
Brushless induction motor	✓	✓	✓	✓	✓	✓	✓	✓	✓	
Tunnel diameter, internal, inches	4 21/64"	4 59/64"	4 59/64"	5 29/32"	5 29/32"	7 9/32"	7 9/32"	7 9/32"	7 9/32"	
Weight excl. tunnel, in lbs	53	53	77	77	77	77	77	77	77	
For DC Systems, Volt	12	12	12	12	24	12	12	24	24	
Current consumption, Amps.	195	265	250	295	190	255	325	250	250	
Operating time - continuously at maximum thrust, in minutes	10	10	10	5	10	10	5	10	10	
- at reduced thrust	Endurance rated*									
Main fuse	ZE200 (200 Amps)	ZE300 (300 Amps)	ZE300 (300 Amps)	ZE300 (300 Amps)	ZE200 (200 Amps)	ZE300 (300 Amps)	ZE300 (300 Amps)	ZE300 (300 Amps)	ZE300 (300 Amps)	ZE300 (300 Amps)
Batteries 12 Volt D.C., min. Ah	1 x 85	1 x 125	1 x 105	1 x 120	2 x 85	1 x 125	1 x 125	2 x 85	2 x 105	
Battery main switch, model BATSW	250	250	250	250	250	250	250	250	250	

For bigger models consult your dealer or our website

* After the given runtime, power may reduce. At less than full power setting, run time depends on battery capacity

BOW PRO DC-AC INDUCTION BOW AND STERN THRUSTERS

BOW PRO 48V thruster series (BOWA)

Tailor made for vessels with electric propulsion

Specifications	BOW PRO 364	BOW PRO 574	BOW PRO 764
Product code	BOWA0364	BOWA0574	BOWA0764
Thrust in N (kgf) (effective power output)	360 (36)	570 (57)	760 (76)
Power kW	1,6	3,1	3,1
Brushless induction motor	✓	✓	✓
Tunnel diameter, internal, inches	4 ^{59/64}	5 ^{29/32}	7 ^{9/32}
Weight excl. tunnel, in lbs	57	68	77
For DC Systems, Volt	48	48	48
Current consumption, Amps.	80	95	105
Operating time	10	10	10
- continuously at maximum thrust, in minutes			
- at reduced thrust		Endurance rated*	
Main fuse	ZE200 (200 Amps)	ZE200 (200 Amps)	ZE200 (200 Amps)
Batteries 12 Volt D.C., min. Ah	4 x 60	4 x 60	4 x 60
Battery main switch, model BATSW	100	150	150

* After 10 minutes full power, power may reduce. At less than full power setting, run time depends on battery capacity

BOW PRO BOOSTED thruster series (BOWB)

BOW PRO with benefits

The BOW PRO Boosted thruster series is innovative and completely different compared to existing thrusters. All the features of the phenomenal BOW PRO with a bonus! On the motor, a third connections is present. This leads the power to the internal charger which boost the output up to double the voltage. In practice, this means you are able to connect the 24 V BOW PRO Boosted to a 12 V power supply and run it without any problems! Connecting the BOW PRO Boosted directly to a 24 V power supply is also possible of course. The built-in charger recharges your battery when the thruster is not in use, doubling the value of the BOW PRO Boosted on board.

Battery advice of the BOW PRO (BOOSTED) series is slightly higher than the advice for the conventional DC thrusters, as run time is decisive for these series. For appropriate control controls please see our options at page 190.



Specifications	BOW PRO BOOSTED 57	BOW PRO BOOSTED 65	BOW PRO BOOSTED 76	BOW PRO BOOSTED 90	BOW PRO BOOSTED 110	BOW PRO BOOSTED 130	BOW PRO BOOSTED 150
Product code	BOWB057	BOWB065	BOWB076	BOWB090	BOWB110	BOWB130	BOWB150
Thrust in N (kgf) (power output)	570 (57)	650 (65)	760 (76)	900 (90)	1100 (110)	1300 (130)	1500 (150)
Power kW	3,1 kW (24V)	3,1 kW (24V)	3,1 kW (24V)	5,7 kW (24V)	5,7 kW (24V)	5,7 kW (24V)	5,7 kW (24V)
Brushless induction motor	✓	✓	✓	✓	✓	✓	✓
Tunnel diameter, internal, inches	5 ^{29/32}	7 ^{9/32}	7 ^{9/32}	7 ^{9/32}	7 ^{9/32}	7 ^{9/32}	9 ^{27/32}
Weight excl. tunnel, in lbs	81.5	81.5	81.5	81.5	81.5	81.5	81.5
For DC Systems, Volt	12 / 24	12 / 24	12 / 24	12 / 24	12 / 24	12 / 24	12 / 24
Current consumption, Amps.	95	130	250	250	275	290	300
Operating time	10	10	10	10	10	10	6
- continuously at maximum thrust, in minutes							
- at reduced thrust			Endurance rated*				
Main fuse	ZE200 (200 Amps)	ZE300 (300 Amps)	ZE200 (200 Amps)	ZE200 (200 Amps)	ZE300 (300 Amps)	ZE300 (300 Amps)	ZE300 (300 Amps)
Batteries 12 Volt D.C., min. Ah	2 x 60	2 x 60	2 x 108	2 x 105	2 x 125	2 x 150	2 x 165
Battery main switch, model BATSW	250	250	250	250	250	250	250

* After the given runtime, power may reduce. At less than full power setting, run time depends on battery capacity

RIMDRIVE DC THRUSTERS

The RD125 and RD160

Peaceful power at your fingertips

The RIMDRIVE is unique in its design; when operating, this thruster is *extremely quiet!* The propeller forms the rotating part of the electric motor (rotor) and the fixed winding (stator) is mounted in the tunnel. Therefore gears are not used in this design. Secondly a ring mounted around the propeller, prevents the propeller from cavitating.

The RIMDRIVE is available in 275.5 lbf and 353 lbf (125 and 160 kgf) and needs a thruster supply voltage of 48 Volt DC. The panel (BPJP) and interface (RDIF) should be ordered separately.

Unique features

- No carbon brushes
- Quiet operation due to a virtually cavitation free propeller and no use of gears
- Proportional control as standard
- Virtually unlimited runtime
- Easy to install
- Maintenance free
- IP67 top cover / ISO 8846 ignition protection compliant
- Lock the thruster at any speed and hold the boat alongside the dock
- Can be used as a stern thruster
- Suitable for aluminum, steel and GRP boats



Model number (dimensions in mm)	RD125	RD160
A	6 11/16" (170)	6 11/16" (170)
B	13 27/64" (341)	13 27/64" (341)
C	7 31/64" (190)	7 31/64" (190)
D min	15 3/4" (400)	15 3/4" (400)
E	14 61/64" (380)	14 61/64" (380)
F	9 23/32" (247)	9 23/32" (247)
G min.	9 27/32" (250)	9 27/32" (250)
H	9 27/32" (250)	9 27/32" (250)

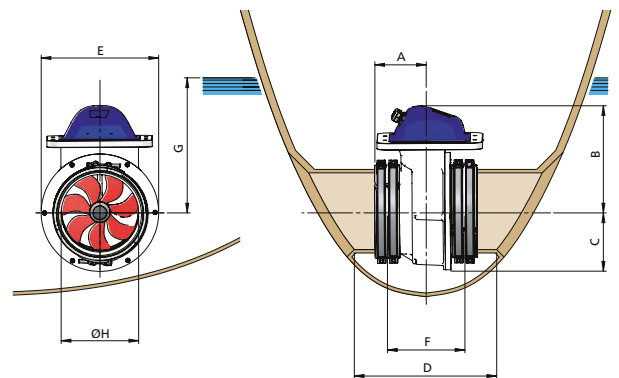

Specifications	RD125	RD160
Thrust, N (kgf) (effective power output)	125 kgf	160 kgf
Power kW (hp)	6.7 (9.1)	9.5 (12.9)
Permanent Magnet Synchronous motor	✓	✓
Variable speed	✓	✓
Tunnel diameter, internal, inches (mm)	9 27/32 (250)	9 27/32 (250)
Weight excluding tunnel, in lbs (kg)	81 (36)	81 (36)
Supply voltage: 12/24 Volt. Thruster Voltage: 48 Volt DC	✓	✓
Motor current consumption @48VDC (A) +/-10%	150	200
Main fuse, "slow blow" (A)	200	250
Batteries, 48 Volt, min Ah (depending on desired runtime)	4x 60 Ah	4x 105 Ah
Battery cables**, total length of positive and negative cables together, feet/in ²	0-32 ft. / 1 in ² 32 ft. plus 1 3/8 in ²	0-32 ft. / 1 3/8 in ² 32 ft. plus 1 15/16 in ²
Battery main switch, model BATSW	250A	250A

** Based on VETUS battery cables

To control the RIMDRIVE we offer the BPJP (further information on this control panel can be found on page 191) and the RDIF, an interface module installed between the thruster and the panel.



BPJP



RDIF

DC STERN THRUSTERS FOR TRANSOM MOUNTING

Stern thruster

Docking was never this easy

Combining a VETUS stern thruster with a VETUS bow thruster, will provide an even greater manoeuvrability of your boat in locks or harbours. By placing a side-directional thruster in the bow and another one at the transom, docking, sailing away, finding a spot in the lock or marina, becomes child's play! Even the effects of wind and current can be effectively countered. Installation of a VETUS stern thruster is simple, the electric motor and other electric components are fitted internally to the transom of the boat. The tunnel and the propeller are installed externally on the transom. **Note:** The range of 7 different stern thruster kits can make 14 different stern thruster models. These kits may also be used with 'ignition protected' thrusters and extended runtime thrusters. For sizes and specifications see details below.



Type	Specifications	Tunnel Ø inches (mm)	
STERN110P	G.R.P. stern thruster	4 ¹¹ / ₃₂	(110)
STERN125P	G.R.P. stern thruster	4 ⁵⁹ / ₆₄	(125)
STERN150P	G.R.P. stern thruster	5 ²⁹ / ₃₂	(150)
STERN185P	G.R.P. stern thruster	7 ⁹ / ₃₂	(185)
STERN250P	G.R.P. stern thruster	9 ⁷ / ₈	(250)
STERN300P	G.R.P. stern thruster	11 ¹³ / ₁₆	(300)
STERN400P	G.R.P. stern thruster	15 ³ / ₄	(400)
STERN25R	Set for stern Rimdrive	9 ²⁷ / ₃₂	(250)

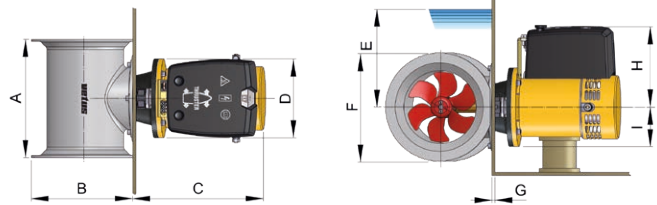

	STERN110P	STERN125P	STERN150P	STERN185P			STERN250P			STERN300P			STERN400P					
COMBINED WITH																		
Size in inches	BOW25	BOW45	BOW35 / BOW55 / BOW55HYDR.		BOW60 / BOW75 / BOW95 / BOW95HYDR.			BOW125 / BOW160 / BOW160HYDR.			BOW220 / BOW230HYDR. / BOW285 / BOW310HYDR.			BOW410HYDR. / BOW550HYDR.				
A	9 ¹ / ₁₆ "	9 ²⁷ / ₃₂ "	10 ⁵ / ₈	10 ⁵ / ₈	10 ⁵ / ₈	11 ¹³ / ₁₆	11 ¹³ / ₁₆	11 ¹³ / ₁₆	11 ¹³ / ₁₆	18 ⁷ / ₆₄	18 ⁷ / ₆₄	18 ⁷ / ₆₄	21 ¹⁷ / ₆₄	21 ¹⁷ / ₆₄	21 ¹⁷ / ₆₄	21 ¹⁷ / ₆₄	29 ⁹ / ₆₄	29 ⁹ / ₆₄
B	6 ⁷ / ₆₄ "	7 ⁹ / ₁₆ "	8 ¹⁵ / ₃₂	8 ¹⁵ / ₃₂	8 ¹⁵ / ₃₂	10 ³⁵ / ₆₄	10 ³⁵ / ₆₄	10 ³⁵ / ₆₄	10 ³⁵ / ₆₄	14 ¹¹ / ₆₄	14 ¹¹ / ₆₄	14 ¹¹ / ₆₄	17 ¹³ / ₆₄	17 ¹³ / ₆₄	17 ¹³ / ₆₄	17 ¹³ / ₆₄	21 ³ / ₈	21 ³ / ₈
C	9 ⁹ / ₆₄ "	10 ⁵³ / ₆₄ "	8 ⁵ / ₈	11 ⁷ / ₆₄	6 ²⁷ / ₆₄	10 ³³ / ₆₄	12	12 ²¹ / ₆₄	5 ¹⁵ / ₁₆	12 ²¹ / ₆₄	14 ¹¹ / ₁₆	6 ³⁹ / ₆₄	16 ³ / ₈	9 ¹⁷ / ₃₂	16 ³ / ₈	9 ¹⁷ / ₃₂	0	0
D	5 ⁵⁵ / ₆₄ "	6 ¹⁹ / ₆₄ "	5 ⁵⁵ / ₆₄	6 ¹⁹ / ₆₄	6 ¹⁹ / ₆₄	6 ¹⁹ / ₆₄	7 ⁷ / ₈	7 ⁷ / ₈	7 ⁷ / ₈	7 ⁷ / ₈	9 ²⁹ / ₆₄	9 ²⁹ / ₆₄	10 ⁵ / ₃₂	10 ⁵ / ₃₂	10 ⁵ / ₃₂	10 ⁵ / ₃₂	0	0
E min.	4 ²¹ / ₆₄ "	4 ⁵⁹ / ₆₄ "	5 ²⁹ / ₃₂	5 ²⁹ / ₃₂	5 ²⁹ / ₃₂	7 ⁹ / ₃₂	7 ⁹ / ₃₂	7 ⁹ / ₃₂	7 ⁹ / ₃₂	9 ²⁷ / ₃₂	9 ²⁷ / ₃₂	9 ²⁷ / ₃₂	11 ¹³ / ₁₆	11 ¹³ / ₁₆	11 ¹³ / ₁₆	11 ¹³ / ₁₆	15 ³ / ₄	15 ³ / ₄
F Ø	7 ³ / ₃₂ "	8 ⁵ / ₆₄ "	9 ²⁹ / ₆₄	9 ²⁹ / ₆₄	9 ²⁹ / ₆₄	10 ⁵³ / ₆₄	10 ⁵³ / ₆₄	10 ⁵³ / ₆₄	10 ⁵³ / ₆₄	14 ⁹ / ₁₆	14 ⁹ / ₁₆	14 ⁹ / ₁₆	17 ²³ / ₃₂	17 ²³ / ₃₂	17 ²³ / ₃₂	17 ²³ / ₃₂	21 ²¹ / ₂₃	21 ²¹ / ₂₃
G max.	1"	1 ⁹ / ₁₆ "	3/4	2 ⁷ / ₃₂	2 ⁷ / ₃₂	1 ¹⁹ / ₆₄	1 ¹ / ₃₂	1 ¹ / ₃₂	1 ¹ / ₃₂	2 ⁹ / ₃₂	3 ⁵ / ₈	3 ⁵ / ₈	1 ³¹ / ₃₂	1 ³¹ / ₃₂	1 ³¹ / ₃₂	1 ³¹ / ₃₂	UNLIMITED	
H	5 ⁷ / ₁₆ "	5 ⁵ / ₈ "	5 ⁵ / ₈	5 ⁵ / ₈	3 ⁵ / ₃₂	5 ⁵ / ₈	6 ⁷ / ₆₄	8 ¹⁵ / ₆₄	3 ¹⁵ / ₁₆	8 ¹⁵ / ₆₄	8 ⁴⁷ / ₆₄	4 ²³ / ₃₂	9 ²¹ / ₆₄	5 ⁵ / ₆₄	9 ²¹ / ₆₄	5 ⁵ / ₆₄	0	0
I	3 ²⁷ / ₆₄ "	4 ³⁹ / ₆₄ "	4 ³⁹ / ₆₄	4 ³⁹ / ₆₄	4 ³⁹ / ₆₄	4 ³ / ₈	4 ³ / ₈	4 ³ / ₈	4 ³ / ₈	4 ³ / ₈	6 ¹ / ₁₆	6 ¹ / ₁₆	6 ⁴⁹ / ₆₄	6 ⁴⁹ / ₆₄	6 ⁴⁹ / ₆₄	6 ⁴⁹ / ₆₄	7 ⁷ / ₈	7 ⁷ / ₈

STERN THRUSTERS FOR TRANSOM MOUNTING

Extension kit for stern thrusters

If the openings of the stern thruster are too close to the waterline, then it will suck air and considerable loss of thrust will occur. This can be prevented by using an extension kit which ensures both tunnel openings are adequately submerged. By installing these deflector shells, the flow of water can also be directed away from transom mounted obstructions including outdrives, trim tabs and swim-platform brackets, maintaining stern thruster effectiveness. The kit consists of 2 fibreglass shells and stainless steel (AISI 316) fastenings. It can easily be retrofitted to existing installations. The SDKIT is available for stern thrusters with tunnels of Ø 4⁵⁹/₆₄, 5²⁹/₃₂, 7⁹/₃₂, 9²⁷/₃₂ or 11¹³/₁₆" (125, 150, 185, 250 or 300 mm).



Type	A	B	C	D	E	F Ø	X (= 1/2 F + A) inches (mm)
SDKIT125	2 ⁵ / ₆₄ (10)	4 ⁷ / ₃₂ (107)	18 ¹⁷ / ₆₄ (464)	7 ³¹ / ₆₄ (190)	8 ⁵ / ₆₄ (205)	4 ⁵⁹ / ₆₄ (125)	Min. 2 ⁷ / ₈ (73)
SDKIT150	1 (27)	7 ⁴³ / ₆₄ (195)	25 ¹⁹ / ₃₂ (650)	8 ²¹ / ₃₂ (220)	9 ⁹ / ₆₄ (232)	5 ²⁹ / ₃₂ (150)	Min. 4 (102)
SDKIT185	4 ³ / ₆₄ (17)	9 ²¹ / ₆₄ (237)	30 ¹ / ₂ (774)	10 ³⁵ / ₆₄ (268)	10 ⁵³ / ₆₄ (275)	7 ⁹ / ₃₂ (185)	Min. 4 ⁵ / ₁₆ (110)
SDKIT250	1 ¹ / ₈ (28)	12 (303)	42 (1066)	14 ¹¹ / ₆₄ (360)	14 ⁹ / ₁₆ (370)	9 ²⁷ / ₃₂ (250)	Min. 6 ¹ / ₃₂ (153)
SDKIT300	1 ¹⁷ / ₃₂ (39)	14 ³ / ₈ (365)	50 (1270)	17 ¹³ / ₆₄ (437)	17 ²³ / ₃₂ (450)	11 ¹³ / ₁₆ (300)	Min. 9 (189)

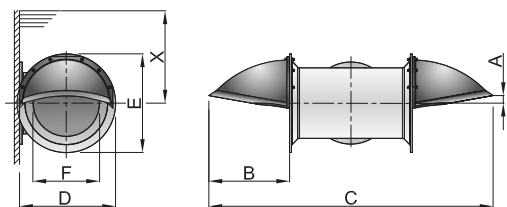

EXTENDED RUNTIME DC BOW AND STERN THRUSTERS

Extended runtime thrusters

Delivers a lot extra!

An extension of the basic, time-tested DC thruster, developed for use in integrated boat control systems requiring long runtimes at high power outputs. For boats ranging from 36 to 75 feet. Extended runtime thrusters can be operated continuously for at least 7 minutes without overheating. There is no doubt that all boaters can benefit highly from these thrusters designed for joystick docking and other more demanding applications.

- On-off, port-starboard controls
- Simple and intuitive to operate
- Simple installation, easy retrofit
- 5 models with power outputs ranging from 209 lbf (95 kgf) to 485 lbf (220 kgf)
- Battery powered at 12 and 24 Volt
- Run time 7-10 minutes continuous or combined in one hour.
- Motor technology: direct current, series wound with carbon brushes



Model number (dimensions in inches)	BOW952DE	BOW954DE	BOW1254DE	BOW1604DE	BOW2204DE
A	8 ⁴⁷ / ₆₄ "	8 ⁴⁷ / ₆₄ "	8 ⁴⁷ / ₆₄ "	9 ²³ / ₃₂ "	9 ²³ / ₃₂ "
B	19 ³ / ₈ "	19 ³ / ₈ "	20 ¹⁹ / ₃₂ "	23 ⁵ / ₈ "	24 ¹¹ / ₁₆ "
C	3 ¹ / ₃₂ "	3 ¹ / ₃₂ "	4 ¹ / ₄ "	4 ¹ / ₄ "	5 ²³ / ₆₄ "
D min/max.	14 ⁹ / ₁₆	14 ⁹ / ₁₆	19 ¹¹ / ₁₆ "	19 ¹¹ / ₁₆ "	23 ⁵ / ₈ "
E	9 ²⁹ / ₆₄ "	9 ²⁹ / ₆₄ "	9 ²⁹ / ₆₄ "	10 ⁵ / ₃₂ "	10 ⁵ / ₃₂ "
F	7 ⁹ / ₃₂ "	7 ⁹ / ₃₂ "	7 ⁹ / ₃₂ "	8 ¹¹ / ₃₂ "	8 ¹¹ / ₃₂ "
G min.	7 ⁹ / ₃₂ "	7 ⁹ / ₃₂ "	9 ²⁷ / ₃₂ "	9 ²⁷ / ₃₂ "	11 ¹³ / ₁₆ "
H	7 ⁹ / ₃₂ "	7 ⁹ / ₃₂ "	9 ²⁷ / ₃₂ "	9 ²⁷ / ₃₂ "	11 ¹³ / ₁₆ "

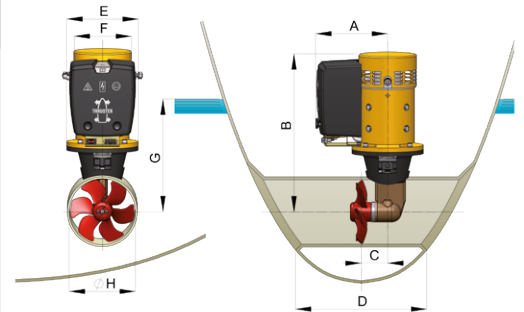

Specifications	BOW952DE	BOW954DE	BOW1254DE	BOW1604DE	BOW2204DE
Thrust in N (kgf) (effective power output)	1050 (105)	1050 (105)	1300 (130)	1600 (160)	2200 (220)
Power kW (hp)	5.7 (8)	5.7 (8)	5,7 (8)	7 (9,5)	11 (15)
Motor, reversible D.C.	✓	✓	✓	✓	✓
Tunnel diameter, internal, inches	7 ⁹ / ₃₂ "	7 ⁹ / ₃₂ "	9 ²⁷ / ₃₂ "	9 ²⁷ / ₃₂ "	11 ¹³ / ₁₆ "
Weight excl. tunnel, incl. packaging, in lbs	76	76	92	139	184
Weight excl. tunnel, excl. packaging, in lbs	69	69	80.4	123.5	153
Voltage, Volt D.C.	12	24	24	24	24
Current consumption, Amps.	350	350	460	450	720
Operating time - continuously, in minutes	10	10	10	10	7
- maximum per hour, in minutes	10	10	10	10	7
Main fuse, "slow blow", Amps.	355	355	500	425	675
Batteries 12 Volt D.C., min. Ah / max. Ah @ 24 V	248/496	248/496	308/616	280/560	325/650
Battery cables**, total length of positive and negative cables together, m/mm ²	0-21/70	0-21/70	0-20/95	0-29/120	0-21/150
Battery main switch, model BATSW / type BPMAIN	600 / 24	600 / 24	600 / 24	600 / 24	***

** Based on VETUS battery cables

*** Currently not available in the VETUS programme

IGNITION PROTECTED DC BOW AND STERN THRUSTERS

Ignition protected thrusters

Watertight and ignition protected motor housing

In compartments with a gasoline/petrol engine, tank or fuel line, or propane gas storage, a thruster must be ignition protected to avoid the possibility of fumes or gas reaching the internal mechanism of the thruster and causing an explosion. All models come with the required seals, electrical connectors, fastening components and an automatic fuse which can be reset externally without having to open the housing. Furthermore the housing is an excellent protection against corrosion.

Characteristics

- Its housing enables thrusters to comply with ISO 8846 Marine 'Ignition protection' standard
- Can be used as a stern thruster in combination with the appropriate kit
- Is supplied with all the required seals, electrical connectors and fastening components
- Has an automatic fuse for the control loom that can be reset from the outside



Model nr (dim. in mm)	BOW 2512EI	BOW 3512EI	BOW 3512FI	BOW 4512DI	BOW5512DI BOW5524DI	BOW7512DI BOW7524DI	BOW9512DI BOW9524DI	BOW 1252DI	BOW 1254DI	BOW 1604DI
A	5 ²³ / ₆₄ "	5 ²³ / ₆₄ "	5 ²³ / ₆₄ "	7 ⁴³ / ₆₄ "	7 ⁴³ / ₆₄ "	9 ³ / ₈ "	9 ³ / ₈ "	9 ³ / ₈ "	9 ³ / ₈ "	10"
B	12 ⁵³ / ₆₄ "	13 ³⁷ / ₆₄ "	13 ²⁵ / ₃₂ "	15 ³ / ₄ "	16 ⁷ / ₃₂ "	18 ⁷ / ₆₄ "	18 ⁷ / ₆₄ "	20 ²³ / ₆₄ "	20 ²³ / ₂₄ "	23 ⁵ / ₆₄ "
C	2 ⁷ / ₈ "	3 ⁷ / ₆₄ "	3 ⁷ / ₆₄ "	3 ⁷ / ₆₄ "	3 ⁷ / ₆₄ "	3 ¹ / ₃₂ "	3 ¹ / ₃₂ "	4 ¹ / ₄ "	4 ¹ / ₄ "	4 ¹ / ₄ "
D min.	8 ²¹ / ₃₂ "	11 ¹³ / ₁₆ "	11 ¹³ / ₁₆ "	9 ²⁷ / ₃₂ "	11 ¹³ / ₁₆ "	14 ⁹ / ₁₆ "	14 ⁹ / ₁₆ "	19 ¹¹ / ₁₆ "	19 ¹¹ / ₁₆ "	19 ¹¹ / ₁₆ "
E	7 ¹ / ₈ "	7 ¹ / ₈ "	5 ⁷ / ₈ "	9 ²⁷ / ₃₂ "	9 ²⁷ / ₃₂ "	11 ²¹ / ₃₂ "	11 ²¹ / ₃₂ "	11 ²¹ / ₃₂ "	11 ²¹ / ₃₂ "	12 ³³ / ₆₄ "
F	6 ³ / ₁₆ "	6 ³ / ₁₆ "	4 ¹³ / ₃₂ "	7 ⁴³ / ₆₄ "	7 ⁴³ / ₆₄ "	9 ²⁹ / ₆₄ "	9 ²⁹ / ₆₄ "	9 ²⁹ / ₆₄ "	9 ²⁹ / ₆₄ "	11 ¹ / ₃₂ "
G min.	4 ²¹ / ₆₄ "	5 ²⁹ / ₃₂ "	4 ⁵⁹ / ₆₄ "	4 ⁵⁹ / ₆₄ "	5 ²⁹ / ₃₂ "	7 ⁹ / ₃₂ "	7 ⁹ / ₃₂ "	9 ²⁷ / ₃₂ "	9 ²⁷ / ₃₂ "	9 ²⁷ / ₃₂ "
H Ø	4 ²¹ / ₆₄ "	5 ²⁹ / ₃₂ "	4 ⁵⁹ / ₆₄ "	4 ⁵⁹ / ₆₄ "	5 ²⁹ / ₃₂ "	7 ⁹ / ₃₂ "	7 ⁹ / ₃₂ "	9 ²⁷ / ₃₂ "	9 ²⁷ / ₃₂ "	9 ²⁷ / ₃₂ "

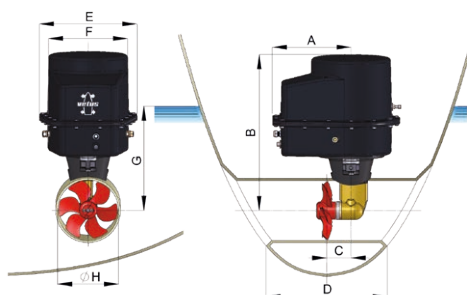

RETRACTABLE DC BOW AND STERN THRUSTERS

Want a thruster but your hull is too shallow for a tunnel thruster? Here's the solution:

For any thruster to work properly, the propeller and the tunnel in which it is mounted must be adequately submerged. Without this, the thruster will create a whirlpool at the water's surface, on the suction side of the boat and pump a mixture of air and water, instead of all water, with a great reduction in thrust.

The minimum submersion of the top of the tunnel/tube/duct is considered to be half of the tunnel/duct/propeller diameter. As an example, the top of the tunnel for a thruster running in a 12" (300 mm) tunnel must be at least 6" (150 mm) below the water. This applies equally to bow and stern thrusters. In addition, a bow thruster must be as far forward as the waterline and underwater profile of the boat will allow, and the stern thruster as far aft as possible, in both cases to create the maximum turning effect when the thruster is activated. If the design of the vessel is such that these forward and aft thruster locations are in parts of the hull which are too shallow for a conventional athwartship (crosswise) tunnel or stern tube to be adequately submerged, then the solution is to install a Retractable thruster.

A VETUS Retractable DC electric thruster is housed entirely inside the hull when not in use, but when sideways force is required for docking or maneuvering, the thruster swings down into the water, then retracts when docking and maneuvering operations are safely completed. These retractable thrusters may be used in bow and stern applications.

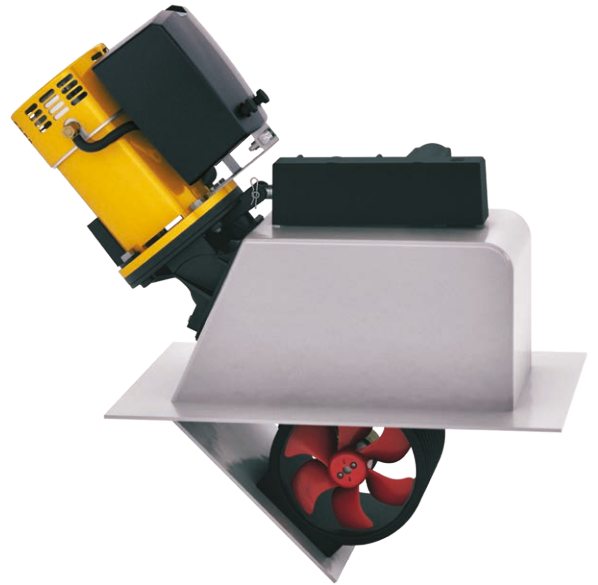

The VETUS retractable has some big advantages

The benefits of the VETUS Retractable Thruster reside in its simplicity, strength, ease of installation and limited service requirements. Those benefits include:

- The ability to equip a shallow draft boat, including a sailboat with a cutaway forefoot and raised stern, with thrusters
- Constructed around a time-tested standard VETUS DC thruster.
- A simple and sturdy swing mechanism, with a minimum of moving parts. The thruster pivots on a permanently lubricated and substantial bearing.
- The propeller revolves in a short duct, creating focused flow and minimum energy losses
- The hull bottom plate (lid) is attached directly to the propeller duct so no additional or complex mechanism is required to open or close it – it swings in and out with the thruster.
- When the thruster is retracted and the bottom plate closed, the retractable creates slightly less drag than a standard tunnel, which may be significant on a racing sailboat
- Fiberglass housing and electronic control mechanism (excl. the dashboard panel and cables) are supplied in the base package.
- The thrusters deploys and retracts automatically, as the control panel is (de-)activated, so no separate controls need to be operated.
- It will also retract automatically if the thruster has not been used in fifteen minutes
- Electronic sensing protects the actuator of the swing mechanism from damage in event of an overload or jam
- There is a one and a half second time delay when changing thrust direction to prevent shock loads on gears, drive mechanism and swing mechanism.
- The thruster(s) and their control panels are connected by cables carrying digital V-CAN signals (VETUS canbus type) allowing future integration into boat-wide electronic systems and information displays

VETUS Retractable Thrusters are suitable for installation in power and sail boats ranging from 30 to 60 feet. They are available at thrust (effective power) ratings of 55 kgf, 60 kgf, 75 kgf, 95 kgf, 125 kgf and 160 kgf, at 12 Volt and 24 Volt. See next page for specifications.

VETUS strongly advises the use of original V-CAN connection cables to ensure an optimal connection between controls and truster.



RETRACTABLE DC BOW AND STERN THRUSTERS

Type	STE5512D	STE5524D	STE6012D	STE6024D	STE7512D	STE7524D
Voltage (V)	12	24	12	24	12	24
Ignition Protection	-	-	-	-	-	-
Thrust (N/kgf) (effective power output)	550/55	600/60	650/65	700/70	800/80	850/85
Power (kW)	3	3	3	3	4,4	4,4
Motor, reversible D.C.	✓	✓	✓	✓	✓	✓
Tunnel diameter, internal (inch)	5 ²⁹ / ₃₂ "	5 ²⁹ / ₃₂ "	7 ⁹ / ₃₂ "	7 ⁹ / ₃₂ "	7 ⁹ / ₃₂ "	7 ⁹ / ₃₂ "
Weight (lbs)	57	57	62	62	68	68
Current consumption (A)	350	200	280	140	500	250
Operating time (min.)	4	4	5	5	2	3
Main fuse, "slow blow" (A)	250	125	200	100	355	200
Batteries 12V min./max. (Ah)	1x105/1x200	2x55/2x70	1x105/1x145	2x70/2x145	1x120/1x225	2x150/2x143
Battery cables, length plus/min cables (m/mm ²)	0-12/70	0-23/35	0-11/50 11-16/70	0-20/25	0-8/70 8-11/95	0-21/50
Battery main switch model BATSW	250	250	250	250	250	250
Dimensions, closed: Height (mm) A	14 ⁷ / ₃₂ "	14 ⁷ / ₃₂ "	15 ¹⁹ / ₃₂ "	15 ¹⁹ / ₃₂ "	15 ¹⁹ / ₃₂ "	15 ¹⁹ / ₃₂ "
Length (mm) B	27 ⁴³ / ₆₄ "	27 ⁴³ / ₆₄ "	28 ²⁷ / ₆₄ "	28 ²⁷ / ₆₄ "	29 ²¹ / ₆₄ "	29 ²¹ / ₆₄ "
Width (mm) C	10 ⁷ / ₁₆ "	10 ⁷ / ₁₆ "	10 ³ / ₄ "	10 ³ / ₄ "	11 ¹⁷ / ₆₄ "	11 ¹⁷ / ₆₄ "
Dimensions, open: Height (mm) D	16 ³ / ₁₆ "	16 ³ / ₁₆ "	18 ¹⁷ / ₆₄ "	18 ¹⁷ / ₆₄ "	18 ¹³ / ₁₆ "	18 ¹³ / ₁₆ "
Length (mm) E	25 ³³ / ₆₄ "	25 ³³ / ₆₄ "	25 ⁷ / ₁₆ "	25 ⁷ / ₁₆ "	26 ⁷ / ₃₂ "	26 ⁷ / ₃₂ "
Width (mm) C	10 ⁷ / ₁₆ "	10 ⁷ / ₁₆ "	10 ³ / ₄ "	10 ³ / ₄ "	11 ¹⁷ / ₆₄ "	11 ¹⁷ / ₆₄ "

Type	STE9512D	STE9524D	STE12512D	STE12524D	STE16024D
Voltage (V)	12	24	12	24	24
Ignition Protection	-	-	-	-	-
Thrust (N/kgf) (effective power output)	950/95	1050/105	1250/125	1400/140	1600/160
Power (kW)	5,7	5,7	5,7	5,7	7
Motor, reversible D.C.	✓	✓	✓	✓	✓
Tunnel diameter, internal (inch)	7 ⁹ / ₁₂ "	7 ⁹ / ₁₂ "	9 ²⁷ / ₃₂ "	9 ²⁷ / ₃₂ "	9 ²⁷ / ₃₂ "
Weight (lbs)	77	77	90	90	108
Current consumption (A)	610	320	800	450	540
Operating time (min.)	3	3,5	3	2,5	4,5
Main fuse, "slow blow" (A)	425	200	500	300	355
Batteries 12V min./max. (Ah)	1x165/2x145	2x105/2x145	1x220/2x200	2x150/2x165	2x165/4x165
Battery cables, length plus/min cables (m/mm ²)	0-10/95 10-12/120	0-21/50	0-9/120 9-12/150	0-20/70	0-29/120
Battery main switch model BATSW	600	250	600	250	600
Dimensions, closed: Height (mm) A	15 ¹⁹ / ₃₂ "	15 ¹⁹ / ₃₂ "	18 ¹⁵ / ₁₆ "	18 ¹⁵ / ₁₆ "	18 ¹⁵ / ₁₆ "
Length (mm) B	30 ⁵ / ₁₆ "	30 ⁵ / ₁₆ "	36 ¹ / ₁₆ "	36 ¹ / ₁₆ "	37 ³¹ / ₆₄ "
Width (mm) C	13 ⁷ / ₆₄ "	13 ⁷ / ₆₄ "	18 ⁵⁷ / ₆₄ "	18 ⁵⁷ / ₆₄ "	19 ⁵⁹ / ₆₄ "
Dimensions, open: Height (mm) D	20 ²³ / ₆₄ "	20 ²³ / ₆₄ "	21 ³¹ / ₃₂ "	21 ³¹ / ₃₂ "	23 ⁵ / ₆₄ "
Length (mm) E	27 ¹¹ / ₆₄ "	27 ¹¹ / ₆₄ "	33 ⁵ / ₁₆ "	33 ⁵ / ₁₆ "	34 ¹ / ₄ "
Width (mm) C	13 ⁷ / ₆₄ "	13 ⁷ / ₆₄ "	15 ⁵⁵ / ₆₄ "	15 ⁵⁵ / ₆₄ "	16 ⁴⁷ / ₆₄ "

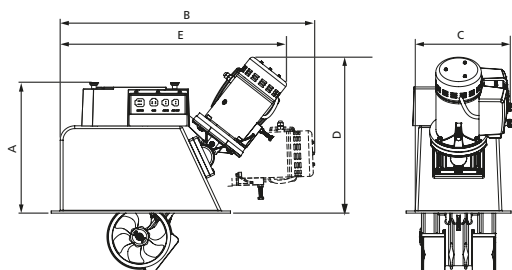

HYDRAULIC BOW AND STERN THRUSTERS

Type BOW..HMD

These are the thrusters for the most demanding of work situations and are available in power outputs of 55 Kilograms Force (Kgf), 95 Kgf, 160 Kgf, 230 Kgf, 310 Kgf, 410 Kgf and 550 Kgf. They operate in hydraulic systems delivering flow rates ranging from 13 litres / 3.4 U.S. gallons per minute to 91 litres / 24 U.S. gallons per minute, at pressures ranging from 165 bar / 2393 p.s.i to 280 bar / 4061 p.s.i., all depending on thruster model selected.

VETUS hydraulic thrusters are able to run continuously, although not as primary propulsion units. They delivery high power and great reliability, with no electrical connections at the thruster or pump(s) and they need little routine maintenance. These thrusters are available with several control heads, in three control regimens, including proportional control.

The skill and knowledge set required to plan, integrate and implement a hydraulic installation work is extensive, and includes all of the skills required to install electric thrusters and a lot more. Such work should not be undertaken by persons, however generally experienced in boat work, who have not received formal training in power hydraulics theory and practice. Access to local hydraulic hose and fitting suppliers is also essential for a well-organized and successful installation.

If an existing hydraulic system can deliver the pressure and flow required by the thruster(s) appropriate for your vessel, it is often possible to add VETUS thrusters to the system, but VETUS also offers complete hydraulic systems as described in this catalogue section.

Whether you buy a complete hydraulic system from VETUS, or just the thrusters, a VETUS customer support team member will review the entire system with you to ensure that your thrusters work well after installation.

See next page for specifications.

The connections and flow of oil for a thruster

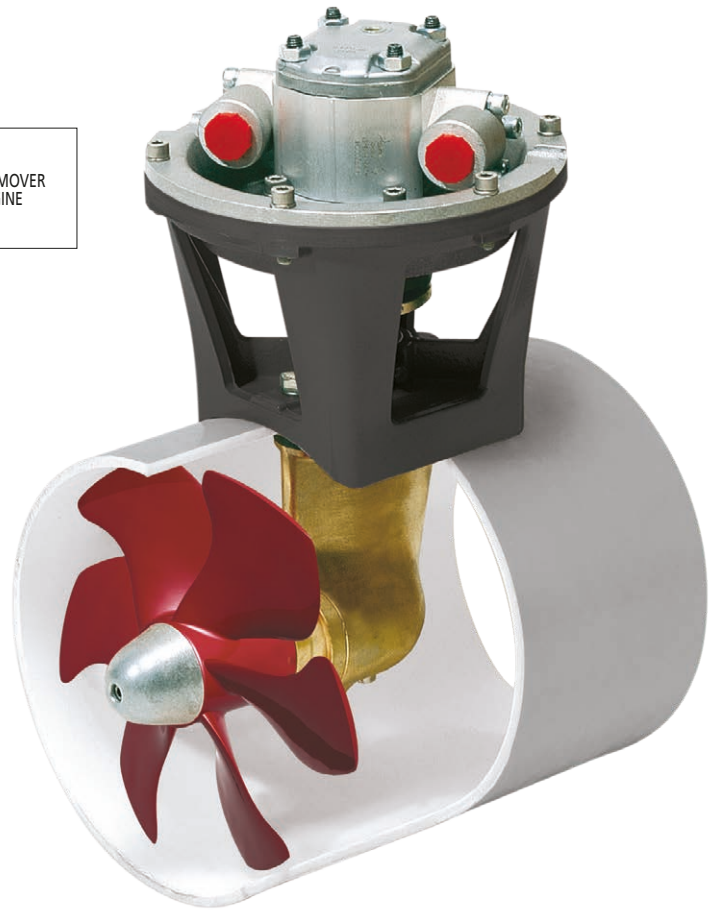
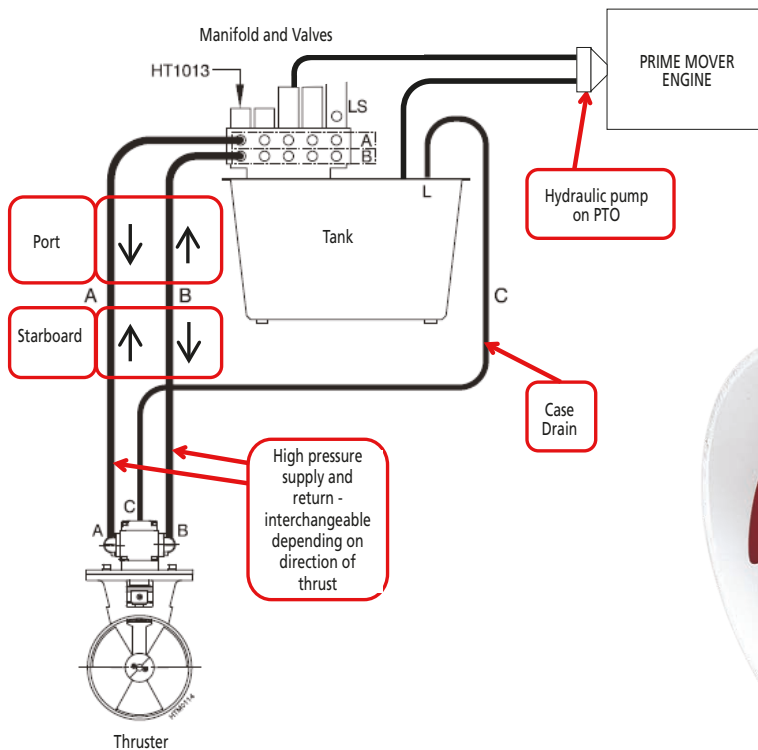

HYDRAULIC BOW AND STERN THRUSTERS

Type BOW...HMD

Specifications	BOW55HMD	BOW95HMD	BOW160HMD	BOW230HMD	BOW310HMD
Thrust N (kgf) (power output)	550 (55)	950 (95)	1600 (160)	2300 (230)	3100 (310)
Hydraulic motor power kW	3,5	6,0	12,3	16,4	26,8
Hydraulic motor speed rpm	3000	4100	3730	2540	2760
Hydraulic motor capacity cm ³ /rev	4,2	4,2	8,4	16,8	27
Flow rate l/min	13	18	28	40	70
Operating pressure bar	165	230	260	245	230
Internal tunnel diameter inches (mm)	5 ²⁹ / ₃₂ (150)	7 ⁹ / ₃₂ (185)	9 ⁷ / ₈ (250)	11 ¹³ / ₁₆ (300)	11 ¹³ / ₁₆ (300)
A mm Ø	6 ⁵ / ₁₆ (160)	7 ⁷ / ₈ (200)	9 ⁷ / ₁₆ (240)	10 ⁵ / ₃₂ (258)	10 ⁵ / ₃₂ (258)
B mm	10 ⁵ / ₃₂ (258)	10 ⁷ / ₈ (276)	13 ¹⁹ / ₃₂ (345)	17 (431)	17 ²⁹ / ₃₂ (455)
C mm Ø	5 ²⁹ / ₃₂ (150)	7 ⁹ / ₃₂ (185)	9 ⁷ / ₈ (250)	11 ¹³ / ₁₆ (300)	11 ¹³ / ₁₆ (300)

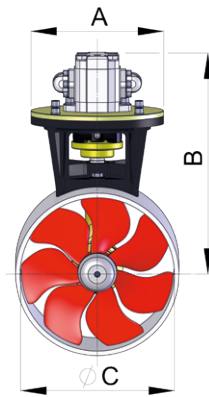

Type	Specifications	Tunnel diam. inches (mm)
BOW55HMD	Hydraulic bow thruster 121 lbf (55 kgf) incl. hydraulic motor 3,5 kW	5 ²⁹ / ₃₂ (150)
BOW95HMD	Hydraulic bow thruster 210 lbf (95 kgf) incl. hydraulic motor 6,0 kW	7 ⁹ / ₃₂ (185)
BOW160HMD	Hydraulic bow thruster 352 lbf (160 kgf) incl. hydraulic motor 12,3 kW	9 ⁷ / ₈ (250)
BOW230HMD	Hydraulic bow thruster 507 lbf (230 kgf) incl. hydraulic motor 16,4 kW	11 ¹³ / ₁₆ (300)
BOW310HMD	Hydraulic bow thruster 665 lbf (310 kgf) incl. hydraulic motor 26,8 kW	11 ¹³ / ₁₆ (300)
BP1053	Bronze propeller for BOW22024D / BOW230HM	
BP1182	Bronze propeller for BOW310HM	

Type BOW...HM

The hydraulic motor for types BOW410HM and BOW550HM is located within the tailpiece.

Specifications	BOW410HM	BOW550HM
Thrust N (kgf) (power output)	4100 (410)	5500 (550)
Hydraulic motor power hp (kW)	30 (22)	45 (33)
Hydraulic motor speed rpm	1920	1920
Hydraulic motor capacity in ³ /rev (cm ³ /rev)	2.75 (45)	2.75 (45)
Flow rate gal./min (l/min)	24 (92)	24 (92)
Operating pressure psi (bar)	2610 (180)	4061 (280)
Internal tunnel diameter inch (mm)	15 ³ / ₄ " (400)	15 ³ / ₄ " (400)

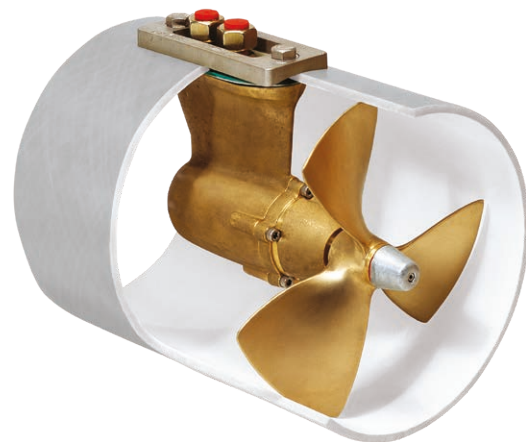

Type	Specifications	Tunnel diam. inches (mm)
BOW410HM	Hydraulic bow thruster 905 lbf (410 kgf), incl. hydro motor 22 kW	15 ³ / ₄ " (400)
BOW550HM	Hydraulic bow thruster 1215 lbf (550 kgf), incl. hydro motor 33 kW	15 ³ / ₄ " (400)
BP1259	Bronze propeller for BOW410HM	
BP1260	Bronze propeller for BOW550HM	

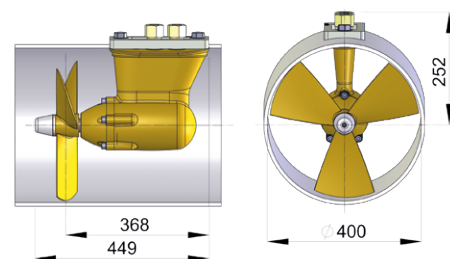

TOTAL BOAT CONTROL SYSTEM - ONE HAND MANEUVERING AND DOCKING

V-DOCKER Joystick

Bow thruster, stern thruster, single engine and gearbox on a single joystick for one hand maneuvering and docking

The V-DOCKER works with a single (mechanically controlled) engine and a combination of a bow and stern thruster. Only this combination ensures an optimal use of the generated forces, giving you the power exactly where you need it! Where other systems make use of opposing forces situated at the stern of the boat, the VETUS systems just needs a nudge of the thruster to tip the bow in the right direction.

Because of the precise cooperation between thrusters and engine, drifting will be a thing of the past. Unlike expensive systems that claim to work without thrusters, the V-DOCKER system evenly distributes the forces between the front and rear of the boat. Maneuvering your boat in a tight spot has never been easier.

This sail-by-wire system replaces your mechanically controlled throttle lever, enabling single-handed boat control! It works with both inboard and outboard engines and is available in two different kits: one kit for those with regular bow thrusters, one kit for the those with retractable thrusters. When there are no thrusters present, these have to be purchased with the kit as well.



Unique features

- Unrivalled ease of installation
- Competitively priced compared to other alternatives on the market
- Pressure-sensitive joystick for precise operating
- Works with one engine, and a combination of bow and stern thruster
- Multiple helm stations are easily connected
- Suitable for retrofit
- The perfect match with:
 - VETUS thrusters
 - VETUS extended runtime thrusters
 - VETUS retractable thrusters

An example of the V-DOCKER fully integrated at the steering position.



Another example of the V-DOCKER installed on a Linjet 43.

TOTAL BOAT CONTROL SYSTEM - ONE HAND MANEUVERING AND DOCKING

V-DOCKER Bow thruster kit (VDSETT)

- Joystick (VDJOY) (a)
- Actuator (VDACT) (b)
- Termination plug (BPCANT) (c)
- CAN Hub (BPCANHUB) 3x (d)
- Security module (VDIO) (e)
- Can interface for thrusters (BPCANIN) 2x (f)
- Power cable (BPCABCPC) (g)
- Standard thruster to CAN cable (BPCABSC) (h)
- Gender change cable (BPCABCGC) (i)

V-DOCKER Retractable thruster kit (VDSETR)

- Joystick (VDJOY) (a)
- Actuator (VDACT) (b)
- Termination plug (BPCANT) (c)
- CAN Hub (BPCANHUB) 3x (d)
- Security module (VDIO) (e)
- Power cable (BPCABCPC) (g)

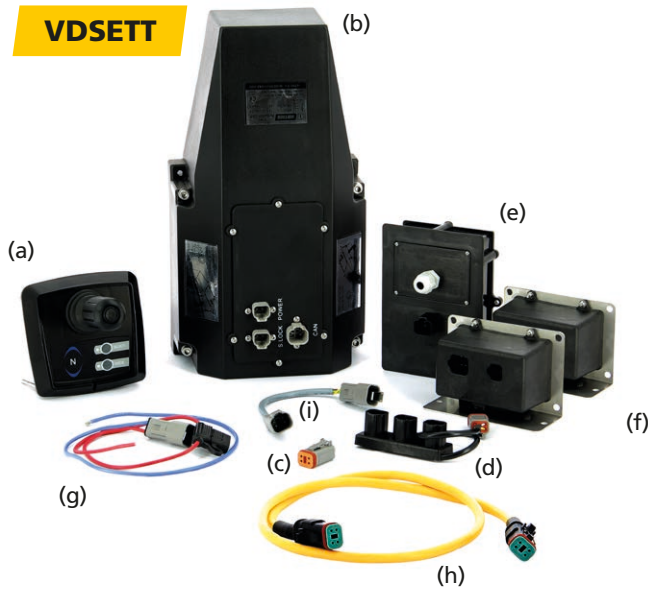

When purchasing a V-DOCKER kit, please base your selection on the type and number of thrusters installed. Both kits can be extended to suit your needs, for example if more joysticks are desired. This kit needs to be complemented with BPCABC CAN cables, with the actual length depending on the size of the vessel. We strongly advise to use these cables only.

Requirements for a complete joystick system ↓	Suitable for (current equipment)					
	Mechanical throttle control Single engine					
	Outboard, no thrusters	Outboard, 1 thruster	Outboard, 2 thrusters	Inboard, no thrusters	Inboard, 1 thruster	Inboard, 2 thrusters
V-DOCKER KIT	-	-	✓	-	-	✓
V-DOCKER RETRACTABLE KIT	-	-	✓	-	-	✓
V-DOCKER BOW KIT +1 THRUSTER (sold seperatly)	-	✓	-	-	✓	-
V-DOCKER RETRACTABLE KIT +1 THRUSTER (sold seperatly)	-	✓	-	-	✓	-
V-DOCKER BOW KIT +2 THRUSTERS (sold seperatly)	✓	-	-	✓	-	-
V-DOCKER RETRACTABLE KIT +2 THRUSTERS (sold seperatly)	✓	-	-	✓	-	-



CONTROL PANELS FOR BOW AND STERN THRUSTERS

Control panels for DC thrusters

Fast and easy installation

These bow thruster panels are available in deluxe or compact versions. Both panels can be easily fitted in a 2³/₆₄" (52 mm) diameter hole. The panels are waterproof to IP65 and provided with a switched outlet (max. 3A) to connect extra equipment. For control panels for hydraulic thrusters, please see page 196. All panels are backwards compatible with other VETUS bow thruster panels and shut down automatically after 30 minutes of inactivity. The thruster switches off after continuous running for more than 2 minutes and resets itself after 5 seconds. Availability with or without time delay device differs per type, please consult the overview below what is applicable for the panel of choice.

Control panels type 2 (EZDOCK2, BPSE2, BPJE2 & BPJDE2) are protected against accidental or unauthorised operation and circuit overload. They have a panel power indicator and warning LED and buzzer in case of continuous running for more than 2 minutes. These panels are easily interconnected and can be fitted at any helm position. The BPSE2, BPJE2, BPJDE2 and EZDOCK2 share the same technical safety features as mentioned above.

The EZDOCK2 combines twin joysticks into one easy operating knob, see the picture on the right. Because the use of hall effect sensors these panels are completely watertight.

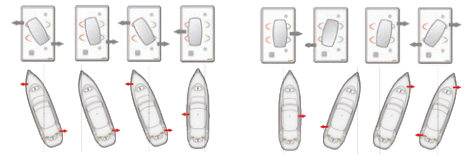

Note

For optimum safety and performance we recommend using VETUS control panels with VETUS thrusters.

Type	Description	Voltage	Front panel (inches)	Bezel	Ingression protected	Built-in depth (inches)	Cut-out size (inches)	Child protection
BPSR	Thruster touch panel with time delay	12 / 24 V	Ø 2 ³¹ / ₆₄	White/Black/Chrome	IP65	3 ³⁵ / ₆₄	Ø 3 ³ / ₆₄	✓
BPJR	Thruster panel with joy-stick and time delay	12 / 24 V	Ø 2 ³¹ / ₆₄	White/Black/Chrome	IP65	3 ³⁵ / ₆₄	Ø 3 ³ / ₆₄	✓
BPAS	Thruster touch panel with time delay	12 / 24 V	3 ¹³ / ₁₆ X 3 ⁴⁷ / ₆₄	Aluminium	IP65	3 ³⁵ / ₆₄	Ø 3 ³ / ₆₄	✓
BPAJ	Joystick with time delay	12 / 24 V	3 ¹³ / ₁₆ X 3 ⁴⁷ / ₆₄	Aluminium	IP65	3 ³⁵ / ₆₄	Ø 3 ³ / ₆₄	✓
BPJSTA	Joystick without time delay device (excl. connection cable)	12 / 24 V	N/A	N/A	IP65	1 ³¹ / ₃₂	Ø 5 ⁵ / ₆₄	-
EZDOCK2	Easy docking system for thrusters, incl. time delay	12 / 24 V	3 ¹¹ / ₃₂ X 5 ⁷ / ₁₆	Synthetic	IP65	3 ³⁵ / ₆₄	5 ¹ / ₈ X 2 ⁶¹ / ₆₄	✓
BPSE2	Thruster touch panel with time delay	12 / 24 V	3 ¹¹ / ₃₂ X 3 ¹¹ / ₃₂	Synthetic	IP65	3 ³⁵ / ₆₄	Ø 2 ⁶¹ / ₆₄	✓
BPJE2	Thruster panel with joy-stick and time delay	12 / 24 V	3 ¹¹ / ₃₂ X 3 ¹¹ / ₃₂	Synthetic	IP65	3 ³⁵ / ₆₄	Ø 2 ⁶¹ / ₆₄	✓
BPJDE2	Thruster panel with two joy-sticks & time delay,	12 / 24 V	3 ¹¹ / ₃₂ X 5 ⁷ / ₁₆	Synthetic	IP65	1 ³¹ / ₃₂	5 ¹ / ₈ X 2 ⁶¹ / ₆₄	✓
BPA	Adapter plate to replace the old BPS/BPJ panels with the new BPSE2/BPJE2 panels							



CONTROL PANELS FOR BOW AND STERN THRUSTERS

Control panels for BOW PRO thrusters

(R)Evolution of epic PROportion

BOW PRO thrusters are controlled by one of the following panels (available separately). Selecting the correct model suitable for your needs. Would you like to have a standard panel, select the Paddle. Are you interested in the 'lock-and-hold' function, the Joystick is the one you are looking for.

Specifications

- Compact design and high quality materials
- Safe and easy proportional control of your vessel
- Aluminium bezel
- Quick installation in $\varnothing 2^{61}/_{64}$ " (75 mm) cut-out hole
- Waterproof housing IP65
- V-CAN CANBUS protocol compliant
- Twin connector for multiple stations
- Status indicator
- Can be flush mounted
- With thruster lock and hold function (BPPJA Panel)



BPPJA



BPPPA

Type	Description	Voltage	Front panel (inches)	Bezel	Ingression protected	Built-in depth (inches)	Cut-out size (inches)	Child protection
BPPJA	Proportional control for the BOW PRO with lock and hold function (CAN BUS)	12 V (V-CAN)	$3^{11}/_{32} \times 3^{11}/_{32}$	Aluminium	IP65	$3^{35}/_{64}$	$\varnothing 2^{61}/_{64}$	✓
BPPPA	Proportional control for the BOW PRO (CAN BUS)	12 V (V-CAN)	$3^{11}/_{32} \times 3^{11}/_{32}$	Aluminium	IP65	$3^{35}/_{64}$	$\varnothing 2^{61}/_{64}$	✓

Control panels for Rimdrive thrusters

Proportional Power

This larger control panel is suitable for the Rimdrive. It works with a 48 V power supply and fits a $\varnothing 3^{5}/_{32}$ " (80 mm) cut-out. The panels is waterproof to IP65 and is provided with a switched outlet (max. 3A) to connect extra equipment. VETUS BPJP shuts down automatically after 30 minutes of inactivity. Safety features switches the thruster off after continuous running for more than 2 minutes and the panel resets itself after 5 seconds. With lock-and-hold function and exclusively compatible with the Rimdrive.



BPJP

Type	Description	Voltage	Front panel (inches)	Bezel	Ingression protected	Built-in depth (inches)	Cut-out size (inches)	Child protection
BPJP	Proportional control for the Rimdrive	48 V	$3^{31}/_{32} \times 3^{15}/_{16}$	Aluminium	IP65	$3^{35}/_{64}$	$\varnothing 3^{5}/_{32}$	✓

Control panels for Retractable thrusters

Control the movement

These bow thruster panels are developed to work with the CAN BUS for the Retractable Thrusters. Both panels can be easily fitted in a $\varnothing 2^{3}/_{64}$ " (52 mm) diameter hole. The panels are waterproof to IP65 and provided with a switched outlet (max. 3A) to connect extra equipment. Safety features shut the panel down automatically after 30 minutes of inactivity. Including time delay device.



BPSRC



BPJRC

Type	Description	Voltage	Front panel (mm)	Bezel	Ingression protected	Built-in depth (mm)	Cut-out size (mm)	Child protection
BPSRC	Thruster touch panel w/ time delay (CAN BUS)	12 / 24 V	$\varnothing 2^{31}/_{64}$	White/Black/Chrome	IP65	$3^{35}/_{64}$	$\varnothing 2^{3}/_{64}$	✓
BPJRC	Thruster panel w/ joy-stick & time delay (CAN BUS)	12 / 24 V	$\varnothing 2^{31}/_{64}$	White/Black/Chrome	IP65	$3^{35}/_{64}$	$\varnothing 2^{3}/_{64}$	✓

CONTROL PANELS FOR BOW AND STERN THRUSTERS

Electric remote control

Always comes in handy

Type RECON can be used for the operation of DC and DC Extended Run time bow and stern thrusters, anchor windlasses, remote controlled gangways, electric cranes, hydraulic steering systems etc. This electric remote control has a stainless steel (AISI 316) hanger loop which is fitted on the back.

Specifications

- Suitable for 12 or 24 Volt D.C.
- Max switching capacity of 6A
- Supplied with three-core spiralled wire of 11.5 feet (3,5 mtr)
- Complete with watertight plug and socket



RECON

Type	Specifications
RECON	Hand held remote control for operation of bow and stern thrusters, windlasses, etc.

Wireless remote control

In control of your electrically driven equipment on board

The WRC remote control system is designed to work with electrically controlled “on-off” devices and not proportionally controlled devices, so is ideal for use with solenoid actuated thrusters and windlasses, including the BOW range of DC thrusters, Extended Runtime thrusters, Ignition Protected thrusters, DC electric windlasses and non-proportional hydraulic thrusters. As with all VETUS Maxwell products, engineering development of this remote control system is ongoing, so please check with your VETUS Maxwell dealer or query our website if you need remote control for a proportionally controlled device such as a BOWPRO or RimDrive.

Specifications WRCBS Receiver

- Receiver accepts 12 or 24 volt power supply
- Connections for (1 or 2 D.C. electric or hydraulic thrusters), or for (1 DC electric or hydraulic thruster and 1 DC electric or hydraulic windlass)
- Maximum 5 hand-held remote transmitters
- Detachable antenna
- Protection class IP40 (for use in dry locations only)

Specifications WRCKF hand-held remote control transmitter

- Power supply - 3 Volt battery type CR2032
- Maximum distance to WRCBS receiver - 32.8 - 82 feet (10 - 25 meters)
- Protection class IP66 (resistant to high pressure water from any direction)



WRCBS

WRCKF

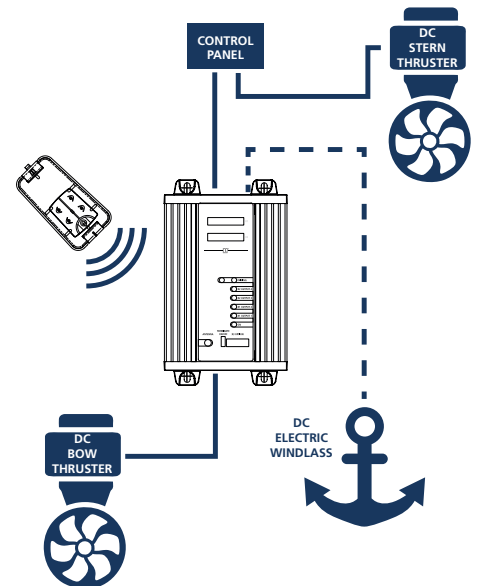

Type	Product description	Dimensions
WRC	Package consists of the WRCBS and the WRCKF	8 ³ / ₁₆ x 4 ⁷ / ₈ x 1 ³¹ / ₃₂ (208 mm x 124 mm x 50 mm)
WRCBS	Base unit for wireless remote control	8 ³ / ₁₆ x 4 ⁷ / ₈ x 1 ³¹ / ₃₂ (208 mm x 124 mm x 50 mm)
WRCKF	Hand held remote control	1 ²¹ / ₃₂ x 3 ⁵ / ₆₄ x 5 ⁵ / ₈ (42 mm x 78 mm x 16 mm)
WRCCAB	Additional connector cable to VETUS bow/stern thruster	1 ⁷ / ₆₄ x 9 ¹ / ₁₆ (28 mm x 230 mm)

ACCESSORIES FOR BOW AND STERN THRUSTERS

Bow thruster control panel for DC and DC Extended Run time thrusters

For side mounting - ideal for sailing boats

Specifications

- With on/off switch and rocker switch
- Diameter 4" (102 mm)
- Build-in depth 3⁷/₆₄" (79 mm)
- Watertight to IP 65
- Without time delay device

Type	Description
BPSM	Bow thruster control panel for side mounting with toggle switch Ø 4" (102 mm)



BPSM

Time delay device

Safety first

Eliminates the risk of the bow thruster being switched over too quickly. It is highly recommended for rental craft to prevent motor damage. Only necessary for BPJSTA and BPSM and only suitable for DC and DC Extended Run time thrusters.

Type	Description
BPTD12	Time delay unit for 12 Volt bow thruster panel BPSM and BPJSTA
BPTD24	Time delay unit for 24 Volt bow thruster panel BPSM and BPJSTA



BPTD

Panel connection cables

These panel connection cables are supplied with multi-plugs and available in 5 different lengths. They can be used with all VETUS electric thrusters except BOW PRO, Rim Drive and retractable thrusters.

Type	Connection cable
BP29	20 ft (6 m) control panel/bow thruster
BP2910	33 ft (10 m) control panel/bow thruster
BP2916	53 ft (16 m) control panel/bow thruster
BP2918	59 ft (18 m) control panel/bow thruster
BP2920	66 ft (20 m) control panel/bow thruster



BP29..

V-CAN connection cables

Available in 6 different lengths for use with BOW PRO, Rimdrive and retractable thruster installations.

Type	Description
BPCABC1M	CAN cable 3 feet (1 m)
BPCABC5M	CAN cable 16 feet (5 m)
BPCABC10M	CAN cable 32 feet (10 m)
BPCABC15M	CAN cable 49 feet (15 m)
BPCABC20M	CAN cable 65 feet (20 m)
BPCABC25M	CAN cable 82 feet (25 m)



BPCABC



ACCESSORIES FOR BOW AND STERN THRUSTERS

Remotely controlled battery main switch and emergency stop

Type BPMAIN

Ideal for use with bow thrusters, anchor windlasses or other high current consumers

A remotely controlled battery switch is in many countries required by law. The BPMAIN can be remotely controlled electrically or activated by hand in an emergency. The switch should be fitted as close as possible to the battery of the bow thruster or other consumers, and should be placed in a position where the red emergency stop button is within reach. For switching on/off a control panel is supplied with pre-wired loom and multi-plugs.

Specifications

- Available in 12 or 24 Volt D.C.
- Extension looms and control panels are optional
- Maximum load 250 Amps continuous or 800 Amps for 3 minutes

Note

When a 24 Volt bow thruster is connected to a 12 Volt circuit by a series/parallel switch, a 12 Volt battery main switch must be selected. When a 48 Volt bow thruster is connected to a 24 Volt circuit by a series/parallel switch, a 24 Volt main switch must be used.



BPMAIN

Type	Description
BPMAIN12	Remotely controlled battery main switch and emergency stop 12 Volt
BPMAIN24	Remotely controlled battery main switch and emergency stop 24 Volt
BPMEC	Extension cable 6mtr for BPMAIN
BPMRC	Remote control for BPMAIN

Battery main switches type BATSW

Twin pole switching

May be connected to either the positive or the negative electric cable. Two positions: "ON" and "OFF". In the "OFF" position the key may be removed (except models 150 and 600). Provided with two M10 connectors. Model 250T is a twin pole switch to make/break both the positive and negative cables. **Model 600 is watertight according to IP 67.** Please see page 232 for technical information.

BATSW075



BATSW100

BATSW150



BATSW250

BATSW250T



BATSW600

Series/parallel switch

Simple and time saving installation

Bow thrusters of 352 lbf and 485 lbf (160 and 220 kgf) are only available in 24 Volt D.C. This series/parallel switch enables them to be connected to a 12 Volt on board supply. When the thruster is operated, the 12 Volt batteries are connected in series to provide the required 24 Volt supply. When the thruster is not operated, they are automatically connected in parallel and linked to the 12 Volt charging system. This series/parallel switch comes with a pre-assembled auxiliary relays to ensure easy connection between the battery bank and the bow thruster. The charging contacts of the series/parallel switch have a continuous duty rating of 100 Amps and an intermittent rating of 150 Amps at 20% duty. The series/parallel switches meet the EMC requirements.

Note

Thruster model BOW28548D is supplied as standard with a series/parallel switch to permit connection to a 24 Volt battery bank. This 24 - 48 Volt series/parallel switch can also be ordered separately: Code BP3008.

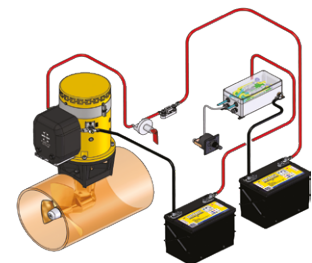

BPSPE



Type	Description
BPSPE	Series parallel switch for 24 Volt thruster with 12 Volt charging system

ACCESSORIES FOR BOW AND STERN THRUSTERS

Tunnels for bow and stern thrusters

VETUS tunnels are available in GRP, steel and aluminium in standard lengths or per metre.

Important note: installer must measure actual external diameter of the tunnel before cutting the hull

Glassfibre reinforced polyester

Type	Internal diameter and length inches (mm)
BP110G75	4 ²¹ / ₆₄ x 29 ¹⁷ / ₃₂ (110 x 750)
BP110G10	4 ²¹ / ₆₄ x 39 ³ / ₈ (110 x 1000)
BP110G30	4 ²¹ / ₆₄ x 118 ⁷ / ₆₄ (110 x 3000)
BP125G10	4 ⁵⁹ / ₆₄ x 39 ³ / ₈ (125 x 1000)
BP125G15	4 ⁵⁹ / ₆₄ x 59 ¹ / ₁₆ (125 x 1500)
BP125G20	4 ⁵⁹ / ₆₄ x 78 ⁴⁷ / ₆₄ (125 x 2000)
BP125G30	4 ⁵⁹ / ₆₄ x 118 ⁷ / ₆₄ (125 x 3000)
BP150G75	5 ²⁹ / ₃₂ x 29 ¹⁷ / ₃₂ (150 x 750)
BP150G10	5 ²⁹ / ₃₂ x 39 ³ / ₈ (150 x 1000)
BP150G15	5 ²⁹ / ₃₂ x 59 ¹ / ₁₆ (150 x 1500)
BP150G30	5 ²⁹ / ₃₂ x 118 ⁷ / ₆₄ (150 x 3000)
BP185G75	7 ⁹ / ₃₂ x 29 ¹⁷ / ₃₂ (185 x 750)
BP185G10	7 ⁹ / ₃₂ x 39 ³ / ₈ (185 x 1000)
BP185G15	7 ⁹ / ₃₂ x 59 ¹ / ₁₆ (185 x 1500)
BP185G20	7 ⁹ / ₃₂ x 78 ⁴⁷ / ₆₄ (185 x 2000)
BP185G30	7 ⁹ / ₃₂ x 118 ⁷ / ₆₄ (185 x 3000)
BP250G10	9 ²⁷ / ₃₂ x 39 ³ / ₈ (250 x 1000)
BP250G15	9 ²⁷ / ₃₂ x 59 ¹ / ₁₆ (250 x 1500)
BP250G20	9 ²⁷ / ₃₂ x 78 ⁴⁷ / ₆₄ (250 x 2000)
BP250G25	9 ²⁷ / ₃₂ x 98 ²⁷ / ₆₄ (250 x 2500)
BP250G30	9 ²⁷ / ₃₂ x 118 ⁷ / ₆₄ (250 x 3000)
BP300G10	11 ¹³ / ₁₆ x 39 ³ / ₈ (300 x 1000)
BP300G15	11 ¹³ / ₁₆ x 59 ¹ / ₁₆ (300 x 1500)
BP300G30	11 ¹³ / ₁₆ x 118 ⁷ / ₆₄ (300 x 3000)
BP400G20	15 ³ / ₄ x 78 ⁴⁷ / ₆₄ (400 x 2000)
BP400G25	15 ³ / ₄ x 98 ²⁷ / ₆₄ (400 x 2500)

Steel

Type	Internal diameter and length inches (mm)
BP110S75	4 ²¹ / ₆₄ x 29 ¹⁷ / ₃₂ (110 x 750)
BP110S10	4 ²¹ / ₆₄ x 39 ³ / ₈ (110 x 1000)
BP110S30	4 ²¹ / ₆₄ x 118 ⁷ / ₆₄ (110 x 3000)
BP125S10	4 ⁵⁹ / ₆₄ x 39 ³ / ₈ (125 x 1000)
BP125S15	4 ⁵⁹ / ₆₄ x 59 ¹ / ₁₆ (125 x 1500)
BP125S30	4 ⁵⁹ / ₆₄ x 118 ⁷ / ₆₄ (125 x 3000)
BP150S10	5 ²⁹ / ₃₂ x 39 ³ / ₈ (150 x 1000)
BP150S15	5 ²⁹ / ₃₂ x 59 ¹ / ₁₆ (150 x 1500)
BP150S30	5 ²⁹ / ₃₂ x 118 ⁷ / ₆₄ (150 x 3000)
BP185S10	7 ⁹ / ₃₂ x 39 ³ / ₈ (185 x 1000)
BP185S15	7 ⁹ / ₃₂ x 59 ¹ / ₁₆ (185 x 1500)
BP185S20	7 ⁹ / ₃₂ x 78 ⁴⁷ / ₆₄ (185 x 2000)
BP185S30	7 ⁹ / ₃₂ x 118 ⁷ / ₆₄ (185 x 3000)
BP250S10	9 ²⁷ / ₃₂ x 39 ³ / ₈ (250 x 1000)
BP250S15	9 ²⁷ / ₃₂ x 59 ¹ / ₁₆ (250 x 1500)
BP250S20	9 ²⁷ / ₃₂ x 78 ⁴⁷ / ₆₄ (250 x 2000)
BP250S25	9 ²⁷ / ₃₂ x 98 ²⁷ / ₆₄ (250 x 2500)
BP250S30	9 ²⁷ / ₃₂ x 118 ⁷ / ₆₄ (250 x 3000)
BP300S10	11 ¹³ / ₁₆ x 39 ³ / ₈ (300 x 1000)
BP300S15	11 ¹³ / ₁₆ x 59 ¹ / ₁₆ (300 x 1500)
BP300S30	11 ¹³ / ₁₆ x 118 ⁷ / ₆₄ (300 x 3000)
BP400S20	15 ³ / ₄ x 78 ⁴⁷ / ₆₄ (400 x 2000)
BP400S25	15 ³ / ₄ x 98 ²⁷ / ₆₄ (400 x 2500)

Aluminium

Type	Internal diameter and length inches (mm)
BP110A75	4 ²¹ / ₆₄ x 29 ¹⁷ / ₃₂ (110 x 750)
BP110A10	4 ²¹ / ₆₄ x 39 ³ / ₈ (110 x 1000)
BP110A30	4 ²¹ / ₆₄ x 118 ⁷ / ₆₄ (110 x 3000)
BP125A75	4 ⁵⁹ / ₆₄ x 29 ¹⁷ / ₃₂ (125 x 750)
BP125A10	4 ⁵⁹ / ₆₄ x 39 ³ / ₈ (125 x 1000)
BP125A30	4 ⁵⁹ / ₆₄ x 118 ⁷ / ₆₄ (125 x 3000)
BP150A10	5 ²⁹ / ₃₂ x 39 ³ / ₈ (150 x 1000)
BP150A30	5 ²⁹ / ₃₂ x 118 ⁷ / ₆₄ (150 x 3000)
BP185A10	7 ⁹ / ₃₂ x 39 ³ / ₈ (185 x 1000)
BP185A30	7 ⁹ / ₃₂ x 118 ⁷ / ₆₄ (185 x 3000)
BP250A10	9 ²⁷ / ₃₂ x 39 ³ / ₈ (250 x 1000)
BP250A30	9 ²⁷ / ₃₂ x 118 ⁷ / ₆₄ (250 x 3000)
BP300A10	11 ¹³ / ₁₆ x 39 ³ / ₈ (300 x 1000)
BP300A15	11 ¹³ / ₁₆ x 59 ¹ / ₁₆ (300 x 1500)
BP300A30	11 ¹³ / ₁₆ x 118 ⁷ / ₆₄ (300 x 3000)



DIESEL POWERPACK

For the most powerful hydraulic bow thrusters

The 3 most powerful VETUS hydraulic bow thrusters can be powered using a specially prepared diesel powerpack instead of a pump on the main engine. The matching hydraulic pump will then be supplied as part of the powerpack. Installing a powerpack on board can reduce the required generator set capacity considerably.

For more information see chapter Power Hydraulics.

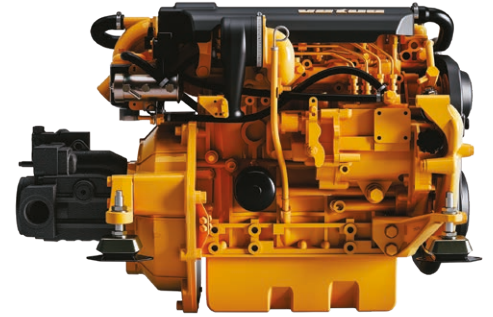

Type	Suitable for
PM4.35 of 24.3 kW (33 hp)	Bow thruster of 682 lbf (310 kgf)
PM4.45 of 30.9 kW (42 hp)	Bow thruster of 902 lbf (410 kgf)
PVH4.65 of 48 kW (65 hp)	Bow thruster of 1210 lbf (550 kgf)

CONTROL PANELS FOR HYDRAULIC BOW AND STERN THRUSTERS

Easy operating

All models have 5 positions - Off and first/second step to either port or starboard. The first détente step will permit continuous hands-off operation at partial power. The second step will provide full power.

Specifications

- Type BJSTH5: Hydraulic bow thrusters 2-step joystick for operation at full or half power (no panel)
- Type BPJ5: Hydraulic bow thruster panel with on/off switch and 2-step joystick for operation at full or half power. Dimensions 3¹¹/₃₂" x 3¹¹/₃₂" (85 x 85 mm)
- Type BPJ5D: Hydraulic bow and stern thruster panel with on/off switch and twin 2-step joysticks for operation at full or half power. Dimensions 3¹¹/₃₂" x 5¹¹/₃₂" (85 x 136 mm)

Note

All models are watertight to IP65.



BJPSTH5



BPJ5



BPJ5D



HT1034

Type	Specification
BJPSTH5	Joystick only for hydraulic bow thrusters (5 positions)
BPJ5	Bow thruster panel with joystick, for hydraulic bow thruster (5 positions)
BPJ5D	Bow thruster panel with two joysticks, for hydraulic bow and stern thruster (5 positions)
HT1034	Proportional bow thruster panel with twistlock for HT1032 and HT1035



POWER HYDRAULICS

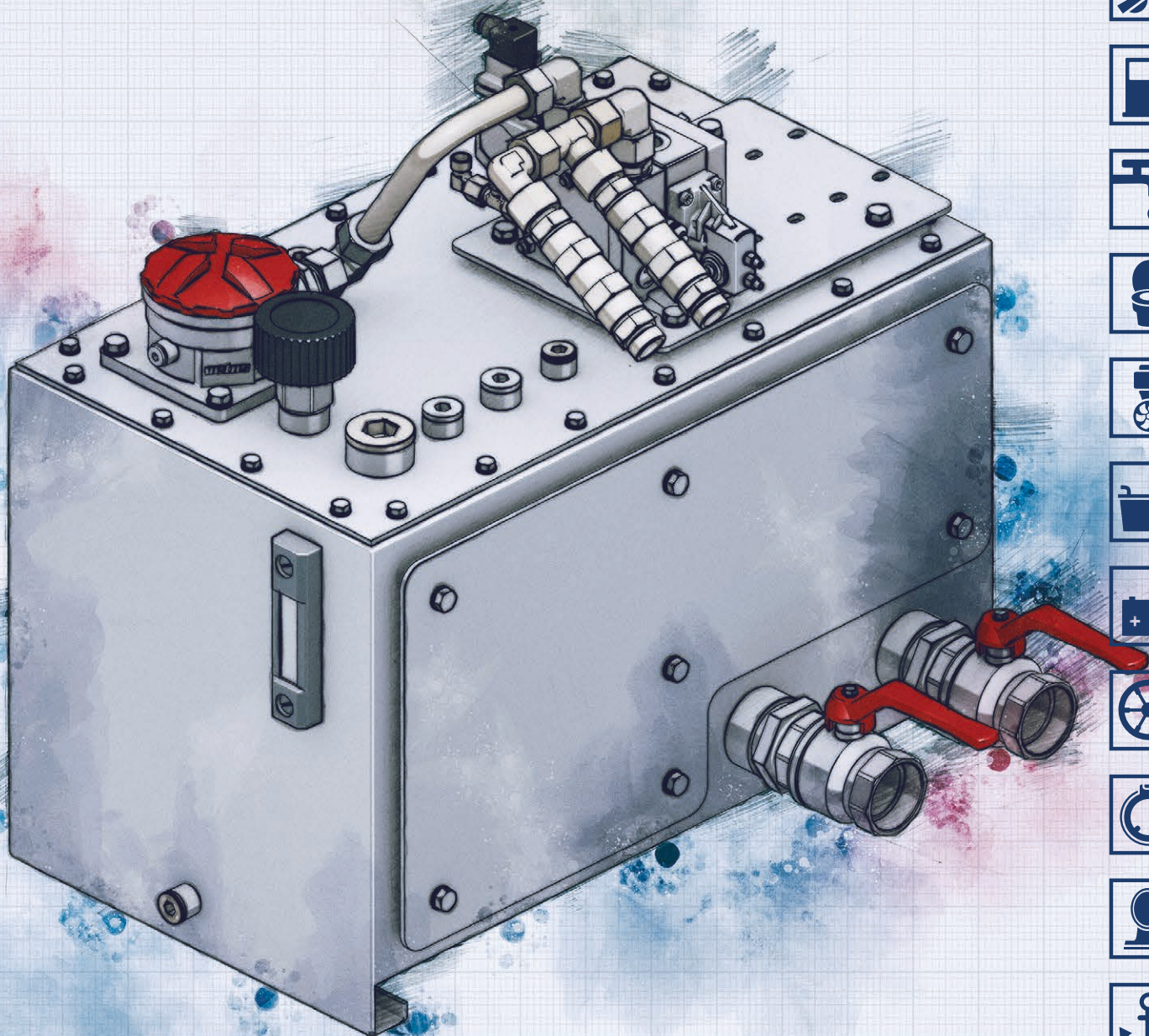

Power hydraulics

Power where you need it, for as long as you need it

The concept

VETUS Hydraulic Systems are an excellent way to move the power of a "Prime Mover" engine to user devices around the vessel, by means of the controlled flow of high pressure fluid moving through flexible hoses or rigid tubes. The prime mover may be a main propulsion engine, the engine of a diesel generator, or a "power pack" engine dedicated to powering the hydraulic system. A user device is any item or system of mechanical equipment, including bow and stern thrusters, windlasses, capstans, winches, cranes, hatch lifters, roll stabilizers and power steering.

The heart of the hydraulic system consists of one or more hydraulic pumps, each mounted on a simple gearbox called a Power Take Off (PTO), itself mounted on an engine or propulsion gearbox. When a main propulsion engine is the prime mover of the hydraulic system, mounting the PTO on the gearbox will usually provide the most convenient installation.

The hydraulic pump draws hydraulic fluid (a light oil) from a reservoir tank, and sends that oil, at high pressure and flow, to valves that then control the flow of fluid to each of the user devices.

VETUS hydraulic pumps are of the variable volume, load sensing type and provided that the prime mover engine is developing enough power, these pumps can deliver maximum flow and pressure at any engine speed. When no user device is operating, the pump essentially freewheels, so no clutch is necessary. The temperature of the hydraulic fluid must be maintained within certain limits and a seawater-cooled oil cooler is installed in almost all systems.

Integrated hydraulic systems require advance planning so that engines or gearboxes are ordered with appropriate PTOs and so that adequate space is reserved in the engine room for the hydraulic reservoir tank. The installation of a hydraulic system requires extensive knowledge of hydraulic theory and practice, with a larger skill set and more training and experience than is required for the installation of electrical devices and equipment.

The cost of installing a single hydraulic user device such as a bow thruster will exceed the cost of installing a single electrically powered device of similar output, but as more devices are added to the vessel and powered by the same central system of pumps, oil coolers and reservoir, there will be a substantial reduction in the cost difference between the integrated hydraulic system and a collection of electrical devices.

Compared to electrical systems:

- Hydraulic systems tend to get less expensive as more devices are installed within the same system (Pump, Tank, Cooler)
- Hydraulic systems tend to get lighter as more devices are installed to the single system
- Hydraulic systems are capable of generating more power compared to their size
- Hydraulic systems in general require less maintenance
 - As far as single devices: An hydraulic thruster requires less maintenance than conventional thruster. But compared to the RIMdrive and BOWpro, the maintenance level is the same
- Hydraulic systems in general are more reliable when looked after properly because most sensitive components stay within the warm, dry conditions of the engine room
- Hydraulic systems have the ability to operate continuously without run-time and overheating limitations compared to conventional electrical system
 - The RIMdrive and BOWpro are examples of electrical systems that have no overheating limitations

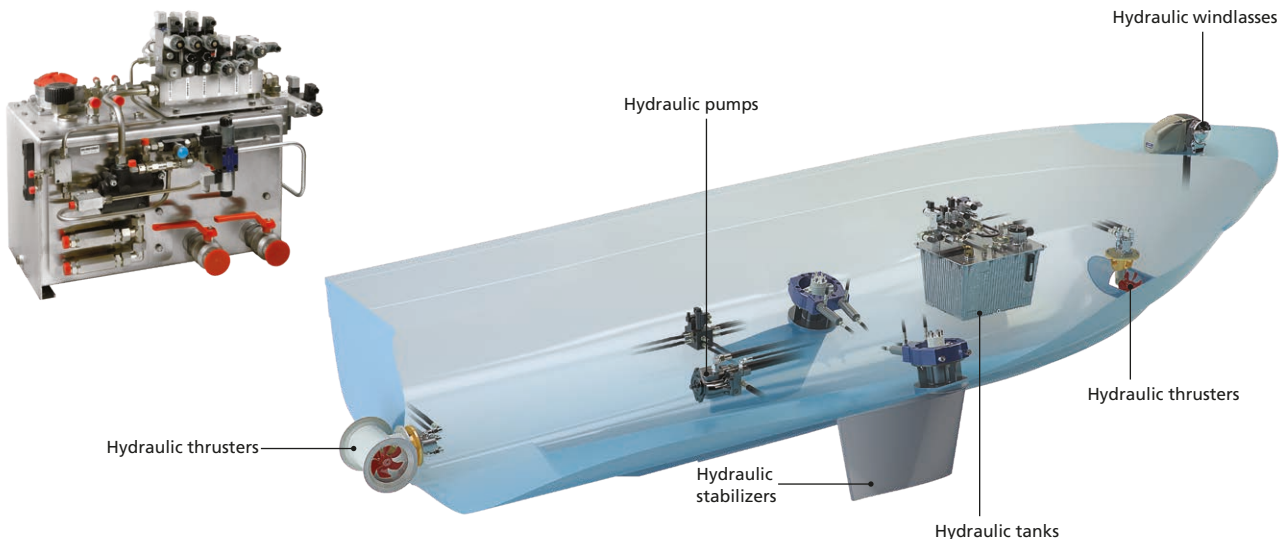
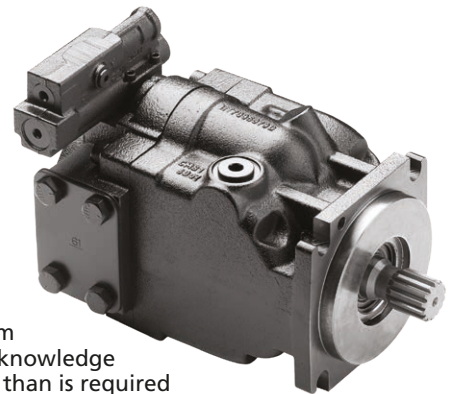

The process

1. Select the hydraulic devices you want to install, using the same calculations and processes used for electric devices
2. Make a list of device combinations that may operate at the same time. (e.g. bow and stern thruster)
3. Determine how much power will be needed by the most demanding of these combinations of devices
4. Identify power sources that can deliver that power (i.e. propulsion engines, propulsion gearboxes, diesel generators, diesel power packs). Remember that propulsion engines are idling during docking manoeuvres and that they must turn the PTOs and the main propellers. In addition, for a propulsion engine mounted PTO to be feasible, there must be adequate clearance between the case of the required pump and the engine block and oil pan/sump
5. Ensure that the propulsion engines, gearboxes and gensets are ordered with SAE B or C flange Power Take Offs (PTOs), rated for the power output needed to drive the most demanding device combination
6. Specify a pump or pumps that can deliver the flow required when the PTO is turning at its standard speed during docking manoeuvres. Take into account the direction of rotation of the PTO (s), and the need to have the pump port locations accessible
7. Select control devices (joysticks, etc.) and the valves to which they connect
8. Select a reservoir tank to store and de-foam the hydraulic fluid
9. Select blocks and manifolds for the control valves
10. Select one or more oil coolers to keep the hydraulic fluid within the appropriate temperature range
11. Install all of the hydraulic equipment and then measure for the required lengths of hydraulic hose and tubing. As the hose or tubing will be required on the vessel within a few working hours of installing the equipment and measuring the hose and tubing runs and as metal fittings must be machine swaged onto hoses, it is usually best to make arrangements for hoses and tubes with a supplier local to the vessel. Important for a correct selection of the hydraulic hose and/or tubing is its function in the system; this determines the maximum oil pressure and the maximum flow rate for which the hose and/or tubing must be suitable
12. Fill the system with the hydraulic fluid specified by VETUS, then commission and adjust all elements of the system

Hydraulic systems are complex and require a lot of expertise but the results are well worth the effort. A VETUS customer support team member is available to you by email, at no cost, to discuss your vessel configuration and usage and to recommend hydraulic user devices and central system equipment. You will receive our recommendations for your Power Hydraulic system within 48 hours of all information being received and finalized. Remember that prime mover engines or gearboxes must be ordered with Power Take Offs, which are difficult or impossible to retrofit.





HYDRAULIC PUMPS

VETUS hydraulic pumps are variable volume, load sensing, piston pumps and are able to provide full hydraulic flow and pressure at all PTO/ prime-mover engine speeds, providing the engine is producing enough power at those speeds. These pumps adjust themselves to meet the requirement of the activated user devices, and when no hydraulic flow is required, stop pumping and freewheel, so no clutch is required at the Power Take Off (PTO) on which the pump is mounted.

Hydraulic pumps are assembled from modules, with many possible arrangements of port locations, mounting flange size, shaft size and type, and direction of rotation. The pumps in the table below will work well for most situations and are available from stock, but VETUS will supply whatever pump is needed for a particular system. For an engine mounted PTO, a pump with rear connections is required, to avoid the pump ports being covered by the engine block or oil pan. In general, a gearbox mounted PTO will be the most convenient, with all round access to pump ports for hose connections.

The direction of rotation of the PTO drive shaft determines the required direction of rotation of the pump, and they will be opposites, when both PTO and pump are viewed looking toward the end of the shaft. A right hand/clockwise PTO needs a left hand/anticlockwise pump and vice versa. In order to transmit the power of the prime-mover engine on which the PTO is mounted, the pump must produce the pressure and flow required by the user devices. To accomplish that power transmission, a pump or pumps is selected with sufficient capacity to produce the required flow at the speed of the PTO(s), allowing for appropriate volumetric inefficiency in the pump(s).

For pumps mounted on propulsion engines or propulsion gearboxes, the PTO speed is taken when the engine is idling, to allow for full hydraulic power to thrusters during docking manoeuvres. For most modern diesel engines idling speed will be between 600 and 700 rpm. For pumps mounted on genset PTOs, the speed of the PTO is taken at the normal operating speed of the genset engine, as listed in the genset manuals (usually 1500, 1800 or 3000 pm).

Your VETUS hydraulic support engineer will work with you to select the correct pumps and all other equipment for your installation, but remember that the engines, gearboxes or gensets must be ordered with appropriate Power Take Offs (PTOs), so early planning of the hydraulic system is essential. Retrofitting PTOs is very expensive and may be impossible.

Each hydraulic pump in the system will have four hose connections: The suction line to draw low pressure oil from the reservoir tank, the high pressure line (P) delivering high potential energy hydraulic fluid to the control valve assembly, the load sensing line (LS) from the valve assembly that controls the output of the pump, and the case drain (D) that prevents hydraulic fluid that has bypassed the internal mechanisms of the pump from accumulating at high pressure in its case. It is important to understand that each pump must have a single load sensing connection. In a multi user-device system, shuttle valves may be required so that the pump provides hydraulic fluid at the highest pressure required by any of the user devices in operation. Other user devices in the system requiring lower pressures will be protected by crossover/bypass valves.

Standard hydraulic pumps stocked by VETUS

Non-standard pumps are made to order.

Part Code	Pump capacity (cc) (fluid pumped in one revolution)	Direction of Rotation	Shaft	Weight lbs (kg) approx	Torque in Newton Metres for each bar of operating pressure *	Suction and pressure port location	Available SAE flange	Max cont rpm
HT1015SD2	45	LH - anticlockwise	13 spline	59.5 (27)	0.72	rear	SAE B 2 bolt	2800
HT1015E62	62	LH - anticlockwise	13 spline	53 (24)	1	rear	SAE B 2 bolt	2600
HT1016SD1	30	LH - anticlockwise	13 spline	53 (24)	0.48	side	SAE B 2 bolt	3200
HT1016SD2	45	LH - anticlockwise	13 spline	59.5 (27)	0.72	side	SAE B 2 bolt	2800
HT1017E62	62	RH - clockwise	13 spline	53 (24)	1	rear	SAE B 2 bolt	2600
HT1017SDI	30	RH - clockwise	13 spline	53 (24)	0.48	side	SAE B 2 bolt	3200
HT1017SD2	45	RH - clockwise	13 spline	59.5 (27)	0.72	side	SAE B 2 bolt	2800
HT1022SD / SDH	75	LH - anticlockwise	14 spline	59.5 (27)	1.2	side	SAE C 4 bolt	2400
HT1023SD / SDH	75	RH - clockwise	14 spline	59.5 (27)	1.2	side	SAE C 4 bolt	2400
HT1016SD3	100	LH - anticlockwise	17 spline	123 (56)	1.6	side	SAE C 4 bolt	2450
HT1016SD4	130	LH - anticlockwise	17 spline	123 (56)	2.1	side	SAE C 4 bolt	2200
HT1027**	45	RH - clockwise	13 spline	59.5 (27)	0.72	side	SAE B 2 bolt	2800

* It may be necessary to reduce pump pressure to avoid exceeding the maximum allowed torque for the PTO, even if that means reduced power for the user device.

** This pump is configured to mount on the PTO of a John Deere diesel engine.

All pumps come standard with a connection kit.

HYDRAULIC PUMPS

Specifications

- Capacity: 3.78 cu.inch (62 cc)
- Rotation: Counterclockwise viewed from end of shaft
- Connection: SAE-B flange, 13 spline shaft
- Rear connection for suction and pressure
- Fits VETUS DEUTZ engines and PRM gearboxes
- Maximum r.p.m.: 2.880



HT1015E62

Specifications

- Capacity: 2.75 cu.inch (45 cc)
- Rotation: Counterclockwise viewed from end of shaft
- Connection: SAE-B flange, 13 spline shaft
- Rear connection for suction and pressure
- Fits VETUS DEUTZ engines and PRM gearboxes
- Maximum r.p.m.: 2.800

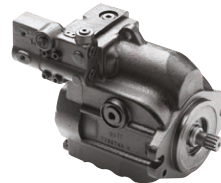

HT1015SD2

Specifications

- Capacity: 3.78 cu.inch (62 cc)
- Rotation: Clockwise viewed from end of shaft
- Connection: SAE-B flange, 13 spline shaft
- Rear connection for suction and pressure
- Maximum r.p.m.: 2.880



HT1017E62

Specifications

- Capacity: 1.83 or 2.75 cu.inch (30 cc (SD1) or 45 cc (SD2))
- Rotation: Counterclockwise viewed from end of shaft
- Connection: SAE-B flange, 13 spline shaft
- Side connection for suction and pressure
- Maximum r.p.m.: 3.600 SD1. / 2.800 SD2



HT1016SD1

HT1016SD2

Specifications

- Capacity: 4.57 cu.inch (75 cc)
- Rotation: Counterclockwise (HT1022SD), clockwise (HT1023SD) viewed from end of shaft
- Connection: SAE-C flange, 14 spline shaft
- Side connection for suction and pressure
- Maximum r.p.m.: 2.880

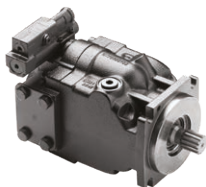

HT1022SD

HT1023SD

Specifications

- Capacity: 1.83 or 2.75 cu.inch (30 cc (SD1) or 45 cc (SD2))
- Rotation: Clockwise viewed from end of shaft
- Connection: SAE-B flange, 13 spline shaft
- Side connection for suction and pressure
- Maximum r.p.m.: 3.600 SD1. / 2.800 SD2

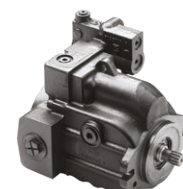

HT1017SD1

HT1017SD2

For John Deere engines, pump type HT 1027 has an extension shaft, for connection to the water pump.

Specifications

- Capacity: 4.57 cu.inch (75 cc)
- Rotation: Counterclockwise (HT1022SDH), clockwise (HT1023SDH) viewed from end of shaft
- Connection: SAE-C flange, 14 spline shaft
- Side connection for suction and pressure
- Maximum r.p.m.: 2.880



HT1022SDH

HT1023SDH

Specifications

- Capacity: 6.1 cu.inch (100 cc) (SD3) or 7.93 cu.inch (130 cc) (SD4)
- Rotation: Counterclockwise viewed from end of shaft
- Connection: SAE-C flange, 17 spline shaft
- Side connection for suction and pressure
- Maximum r.p.m.: 2.800



HT1016SD3

HT1016SD4

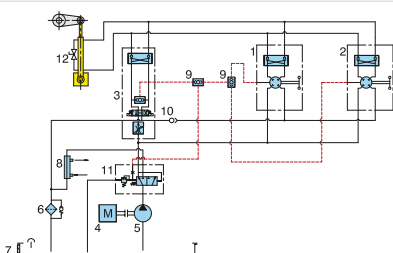

Diagram of a single hydraulic drive

It is possible to connect various equipment devices to one hydraulic pump.

1. Hydraulic motor
2. High pressure pump
3. Solenoid control valve
4. Propulsion engine
5. Hydraulic pump
6. Storage tank hydraulic fluid



BRACKETS

A hydraulic pump is an essential part of any hydraulic system. This pump can be installed on the PTO of the main engine or the gearbox if this is possible. However, if there is no PTO, or if the PTO does not have an SAE-B or SAE-C flange, it is often possible to install the pump on the front of the engine using a pump bracket. This is a complicated job, which requires considerable skill and expertise.

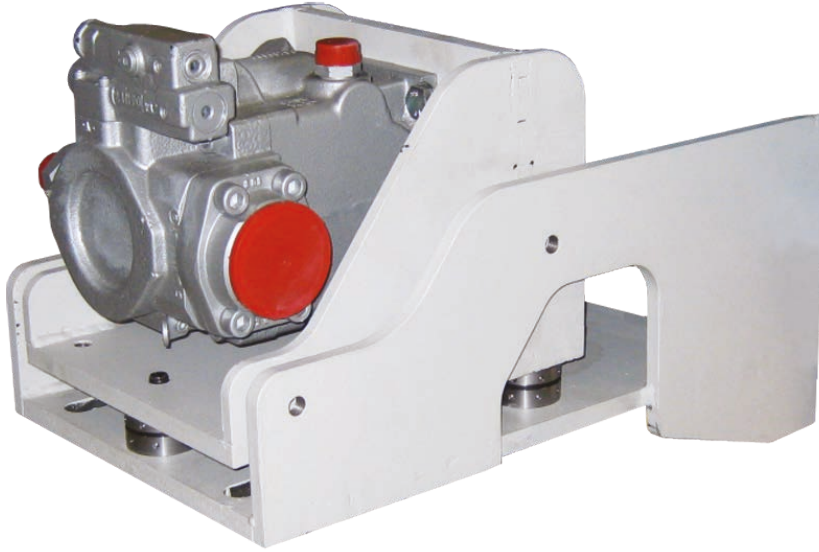

To simplify this task, VETUS has developed pump mounting brackets for a number of popular engines, capable of generating enough power for PTO operation. For propulsion engines, only large displacement engines are capable to do the job because they have to generate high power and torque levels on idle for docking and close quarter maneuvering. For gensets and powerpacks this is not the case since they are allowed to operate in their most efficient rev. range. We supply an accurate and custom made plate package for the pump bracket, which is pre-drilled and tapped with all necessary holes. The bracket is supplied un-welded and unpainted. The kit also includes a crankshaft adaptor and a flexible coupling to suit the hydraulic pump and your particular engine.

Attention: This package includes all the required components, but the installation of a hydraulic pump in this way requires professional expertise. In some cases small adjustments must be made to the appendages, etc.

Currently available for various engines, prices available on request.

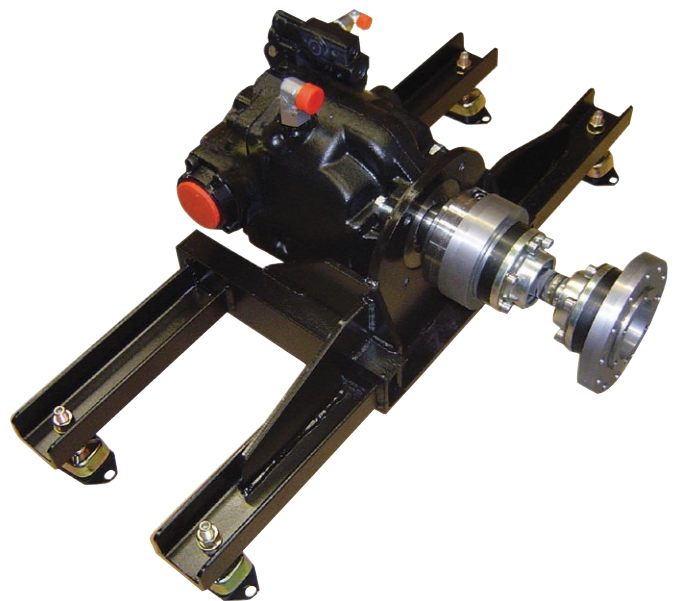
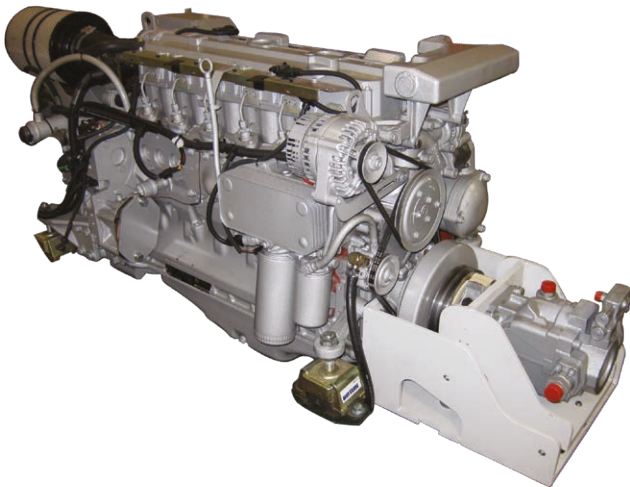

HYDRAULIC TANKS

Hydraulic systems require the installation of a hydraulic tank, as a collection point for hot hydraulic fluid returning from all of the user devices in the system, and as a reservoir from which the pump or pumps can draw the hydraulic fluid and re-pressurize it for re-use. The returning hydraulic fluid foams when it reaches the tank and returns to atmospheric pressure. So the tank must be sized so that the fluid is in the tank long enough for the foam to “boil out”, returning the fluid to a completely liquid state, able to maintain its volume as it is re-pressurized by the pump(s).

Aluminum alloy tanks HT1010 and HT1028 may contribute to cooling of the hydraulic fluid, but as the rate of cooling depends on the engine room air temperature and convective air flow over the surfaces of the tanks the difference in temperature between the outer face of the tank and the ambient air temperature around the tank (Δt) (itself dependent on engine room air temperature and freedom of air movement for convection), the cooling capacity of the tank is unpredictable. Therefore, VETUS recommends that sea-water cooled hydraulic fluid (oil) coolers be included in all systems. If for reasons of economy, an oil cooler is not initially installed, operating temperatures must be carefully monitored and an oil cooler retrofitted if necessary.

- The lid of this hydraulic tank serves as the base plate for all control units required to operate the various hydraulic devices
- VETUS supplies this hydraulic tank ready to use and preinstalled with all control units ordered
- Additional control units can be supplied as separate components, if required
- Tagged for connections
- Mounted so that suction hose runs down to pumps
- Connections for more than one pump
- Mounted on bulkhead, shelf or platform built by installer or OEM
- Valves mounted on lid for convenience
- Space for the tank must be planned and reserved in the engine room, adjacent to the pumps

The table shown below provides guidance for tank selection for systems driving thrusters. All other device will be covered if the system is adequately sized for the thrusters.

Hydraulic reservoir tanks

Examples of hydraulic reservoir tanks.

HT1010

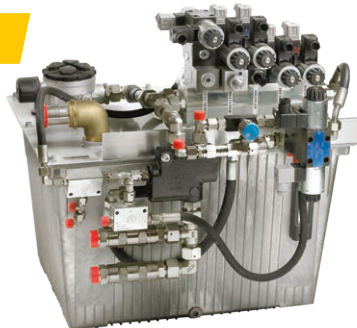

HT1010BS



HPTANK

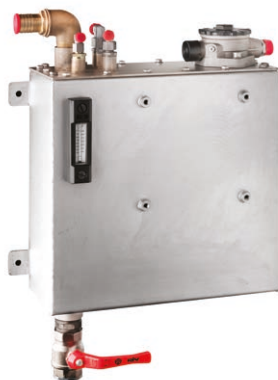

HT1028B



Tank type	HT1028B	HPTANK	HT1010	HT1010BS
Tank capacity gallon (litres)	5 (20)	10 (38)	9 (35)	4 (17)
Weight lbs (kg)	75 (34)	150 (68)	64 (29)	53 (24)
Total height inches (mm)	19 ¹⁹ / ₆₄ (490)	22 ⁵³ / ₆₄ (580)	22 ¹ / ₄ (565)	16 ¹¹ / ₃₂ (415)
Wide inches (mm)	24 ¹³ / ₃₂ x 18 ⁵⁷ / ₆₄ (620 x 480)	28 ⁴⁷ / ₆₄ x 23 ⁵ / ₈ (730 x 600)	20 ⁵⁵ / ₆₄ x 8 ¹⁷ / ₆₄ (530 x 210)	18 ¹ / ₂ x 12 ¹³ / ₆₄ (470 x 310)
Volt	24 (12 on request)	24 (12 on request)	24 (12 on request)	24 (12 on request)
Vibration dampers (ordered separately) Height inches (mm)	HT3010 (set of 4) 19 ¹⁹ / ₃₂ (15)	HT3010 (set of 4) 1 ³ / ₁₆ (30)	HT3010 (set of 4) 1 ³ / ₁₆ (30)	HT3020 (set of 4) 1 ³ / ₁₆ (30)
Material body	aluminium alloy	stainless steel (AISI 316)	aluminium alloy	stainless steel (AISI 316)



HYDRAULIC TANKS

The chart below provides a guideline for tank types for systems including thrusters, although this will be reviewed by your VETUS Power Hydraulics support engineer in developing the equipment list for your system. In most circumstances, all other devices will be covered if the tank is big enough for the thrusters.

Tank specifier for thruster systems

Tank type	One thruster				Two thrusters				
	HT1028B	HPTANK	HT1010	HT1010BS	HT1028B	HPTANK	HT1010	HT1010BS	
Tank Capacity gallon (litres)	5 (20)	10 (38)	18 (70)	34 (130)	5 (20)	10 (38)	18 (70)	34 (130)	
Maximum oil contents gallon (litres)	4 (18)	9 (35)	16 (63)	30 (117)	4 (18)	9 (35)	16 (63)	30 (117)	
Approx. weight of oil in lbs (kg)	37.5 (17)	70.5 (32)	128 (58)	236 (107)	37.5 (17)	70.5 (32)	128 (58)	236 (107)	
Dry (empty) of tank in lbs (kg)	53 (24)	64 (29)*	75 (34)	150 (68)**	53 (24)	64 (29)*	75 (34)	150 (68)**	
Approx weight of full tank in lbs (kg)	90 (41)	134 (61)	203 (92)	386 (175)	90 (41)	134 (61)	203 (92)	386 (175)	
Approx height overall including valves and dampers inches (mm)	16 ⁵⁹ / ₆₄ (430)	22 ¹ / ₄ (565)*	26 ⁴⁹ / ₆₄ (680)	24 ¹ / ₆₄ (610)**	16 ⁵⁹ / ₆₄ (430)	22 ¹ / ₄ (565)*	26 ⁴⁹ / ₆₄ (680)	24 ¹ / ₆₄ (610)**	
Approx length inches (mm)	18 ¹ / ₂ (470)	20 ⁵⁵ / ₆₄ (530)	24 ¹³ / ₃₂ (620)	28 ⁴⁷ / ₆₄ (730)**	18 ¹ / ₂ (470)	20 ⁵⁵ / ₆₄ (530)	24 ¹³ / ₃₂ (620)	28 ⁴⁷ / ₆₄ (730)**	
Approx depth overall including valves inches (mm)	12 ¹³ / ₆₄ (310)	16 ⁵⁹ / ₆₄ (430)***	18 ⁵⁷ / ₆₄ (480)	23 ⁵ / ₈ (600)**	12 ¹³ / ₆₄ (310)	16 ⁵⁹ / ₆₄ (430)***	18 ⁵⁷ / ₆₄ (480)	23 ⁵ / ₈ (600)**	
Additional minimum clearance required at top for filling and filter maintenance	250	300	250	350	250	300	250	350	
Thruster type	Single thruster flow rate gallon (litres) per minute								
BOW55HMC	3 (13)	✓	✓	✓	✓	x	✓	✓	✓
BOW95HMC	4 (18)	✓	✓	✓	✓	x	✓	✓	✓
BOW160HMC	6 (24)	x	✓	✓	✓	x	x	✓	✓
BOW230HMC	8 (33,5)	x	✓	✓	✓	x	x	✓	✓
BOW310HMC	15 (57)	x	x	✓	✓	x	x	x	✓
BOW410HM	24 (92)	x	x	x	✓	x	x	x	✓
BOW550HM	24 (92)	x	x	x	✓	x	x	x	✓

* No manifold/valve block or valves can be mounted on the top of the HP tank

** This weight or dimension does not include valves, blocks or manifolds, as these are assembled to each customer's order

*** It is possible, with a mounting plate, to install a manifold and valves on the front of the HP tank, but those dimensions are not included here

The weights and dimensions provided in this chart are approximate and will vary with each tank, manifold and valve assembly, but for a successful installation, it is essential that adequate space and support is planned and designed into the engine room for the tank assembly and hydraulic pumps.

Manifold for additional control units

An extension of the basic manifold block. Required if more than 5 solenoid control devices are installed. Includes additional electrical connection box.

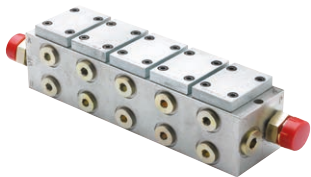

HT1026



Hydraulic oil

We recommend the use of the following hydraulic fluids: VETUS Hydraulic oil HT (HLP ISO-VG46).

Type	Specification
VHT1	1 L ISO VG 46
VHT4	4 L ISO VG 46
VHT20	20 L ISO VG 46



VHT

HYDRAULIC LOAD SENSING AND CONTROL DEVICES

In order to direct the oil flow from the hydraulic pump to the equipment to be driven, load sensing and control devices, which are built up in modular construction segments, are used. These ensure the correct speed and sense of rotation of the equipment to be driven. Supplied as standard for 24 Volt electric installations, 12 Volt on request.

HT1011

Single step load sensing device (24 Volt). Gives zero or full flow rate, depending on whether a load is sensed or not. Used for e.g. bow and stern thrusters. Includes electrical connection box.



HT1011



HT1012

Dual step load sensing device (24 Volt). Gives zero, partial or full flow rate, dependent on load sensed. Used for e.g. bow and stern thrusters. Includes electrical connection box.



HT1012

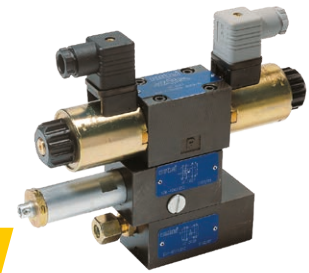

HT1013

Solenoid control unit (24 Volt) for bow and stern thrusters.



HT1013

HT1014

Solenoid control unit (24 Volt) with counterbalance, for e.g. mast lowering, hinged radar support (or any other hydraulic cylinder for numerous applications).



HT1014



HT1024

Solenoid control unit (24 Volt) for use with a set of stabilisers.

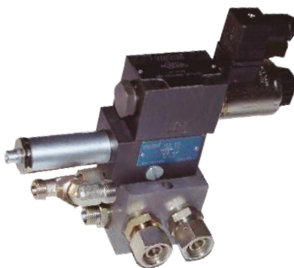

HT1024

HT102311

Control unit for anchor winches, capstans and other applications which are driven by a hydromotor with a flow rate of up to 60 litres/minute. Pressure and oil flow separately adjustable.

HT102312

Control unit for anchor winches, capstans and other applications which are driven by a hydromotor with a flow rate of up to 60 litres/minute. Only the oil flow is adjustable.

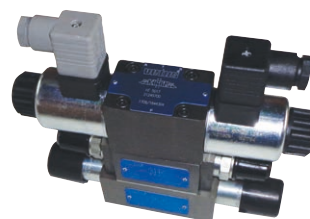

HT102311



HT102312



HYDRAULIC THRUSTER CONTROL JOYSTICKS

BPJSTA

Joy-stick (3-positions) for operation, with full thrust only, of a hydraulic bow- OR stern thruster. Only suitable for a single step load-sensing device (HT1011). Intended for dashboard mounting, without panel, without on/off switch.

Watertight to IP 65.

BPJSTA



BPJSTH5

Joy-stick (5-positions) for operation, with full or half thrust, of an hydraulic bow- OR stern thruster in combination with a dual step load-sensing device (HT1012). Intended for dashboard mounting, without panel, without on/off switch.

Watertight to IP 65.

BPJSTH5



BPJ5

Control panel with on/off switch and one 5-positions joy-stick. Intended for operation, with full or half thrust, of an hydraulic bow- OR stern thruster in combination with a dual step load-sensing device (HT1012).

Watertight to IP 65.

BPJ5



BPJ5D

Control panel with on / off switch and two 5-positions joy-sticks. Intended for operation, with full or half thrust, of an hydraulic bow thruster AND stern thruster in combination with two dual step load-sensing devices (HT1012).

Watertight to IP 65.

BPJ5D



HT5034

This electrical connection box is supplied with type HT1011, HT1012 and HT1026.

HT5034



Type	Specification
HT1011	Single step load sensing device, incl. electrical connection box
HT1012	Dual step load sensing device, incl. electrical connection box
HT1013	Solenoid control unit 24 V, for bow and stern thrusters, (12 V available to special order)
HT102311	Control unit 24 V, for anchor windlass, (12 V available to special order)
HT102312	Control unit 24 V, for anchor windlass, (12 V available to special order)
BPJSTA	Joystick switch only for dashboard mounting
BPJSTH5	Joystick only for hydraulic bow thrusters (5 positions)
BPJ5	Bow thruster panel with joystick, for hydraulic bow thruster (5 positions)
BPJ5D	Bow thruster panel with two joysticks, for hydraulic bow and stern thruster (5 positions)
HT5034	Electrical connection box

PROPORTIONAL VALVES

HT1032/35

Proportional valve assemblies. HT1032 for one thruster or windlass HT1035 for two thrusters or a thruster and a windlass. These valves can be mounted on a HT1010 tank.



HT1032



HT1035

Model HT1034 Proportional control joystick

Single joystick control.
The LED lights up when the joy-stick is opening the proportional valve.
The LED will go out when the joy-stick is in neutral.

The LED can be installed in one of the mounting holes of the joystick.



HT1034

Thruster type	Valve type	Valve Assembly or Part Number	
		on/off-directional	Two stage, Load sensing
BOW55HMD	Direct operating	HT1013	HT1012
	Proportional	HT1032	Not applicable
BOW95HMD	Direct operating	HT1013	HT1012
	Proportional	HT1032	Not applicable
BOW160HMD	Direct operating	HT1013	HT1012
	Proportional	HT1032	Not applicable
BOW230HMD	Direct operating	HT1013	HT1012
	Proportional	HT1032	Not applicable
BOW310HMD	Direct operating	HT1013	HT1012
	Proportional	HT1032	Not applicable
BOW410HM	Direct operating	Not applicable	Not applicable
	Proportional	HT1032	Not applicable
BOW550HM	Direct operating	Not applicable	Not applicable
	Proportional	HT1032	Not applicable

Note HT1012 two stage, load-sensing valve set is supplied standard with an HT5034 electrical junction box.

For systems not incorporating an HT1011 or HT1012 load sensing valve, the HT5034 electrical junction box must be ordered separately, if required.

For systems including an HT1010 reservoir tank, one HT1013 on/off, directional valve is supplied standard with the tank, but the HT1012 two stage, load-sensing valve set must still be ordered separately. If the system incorporates two thrusters with proportional control, then an HT1035 dual valve assembly will be supplied, rather than two HT1032s.

For electronic control of any thruster, as required for integrated joystick systems, dynamic positioning/station holding systems, etc., proportional valves must be used, with connection heads specified for electronic compliance with the output of the electronic control system.

When a proportional valve such as the HT1032 is specified, the valve will be set up by Vetus to match the flow requirements of the thruster or other device. Without such an adjustment, control range may be drastically reduced. Please discuss this with your VETUS hydraulic support engineer when completing your order.



HYDRAULIC BOW AND STERN THRUSTERS

Type BOW..HMD

These are the thrusters for the most demanding of work situations and are available in power outputs of 55 Kilograms Force (Kgf), 95 Kgf, 160 Kgf, 230 Kgf, 310 Kgf, 410 Kgf and 550 Kgf. They operate in hydraulics systems delivering flow rates ranging from 13 litres / 3.4 U.S gallons per minute to 91 litres / 24 U.S. gallons per minute, at pressures ranging from 165 bar/ 2393 p.s.i to 280 bar / 4061 p.s.i., all depending on thruster model selected.

VETUS hydraulic thrusters are able to run continuously, although not as primary propulsion units. They deliver high power and great reliability, with no electrical connections at the thruster or pump(s) and they need little routine maintenance. These thrusters are available with several control heads, in three control regimes, including proportional control.

The skill and knowledge set required to plan, integrate and implement a hydraulic installation work is extensive, and includes all of the skills required to install electric thrusters and a lot more. Such work should not be undertaken by persons, however generally experienced in boat work, who have not received formal training in power hydraulics theory and practice. Access to local hydraulic hose and fitting suppliers is also essential for a well-organized and successful installation.

If an existing hydraulic system can deliver the pressure and flow required by the thruster(s) appropriate for your vessel, it is often possible to add VETUS thrusters to the system, but VETUS also offers complete hydraulic systems as described in this catalogue section.

Whether you buy a complete hydraulic system from VETUS, or just the thrusters, a VETUS customer support team member will review the entire system with you to ensure that your thrusters work well after installation.

See next page for specifications.

The connections and flow of oil for a thruster

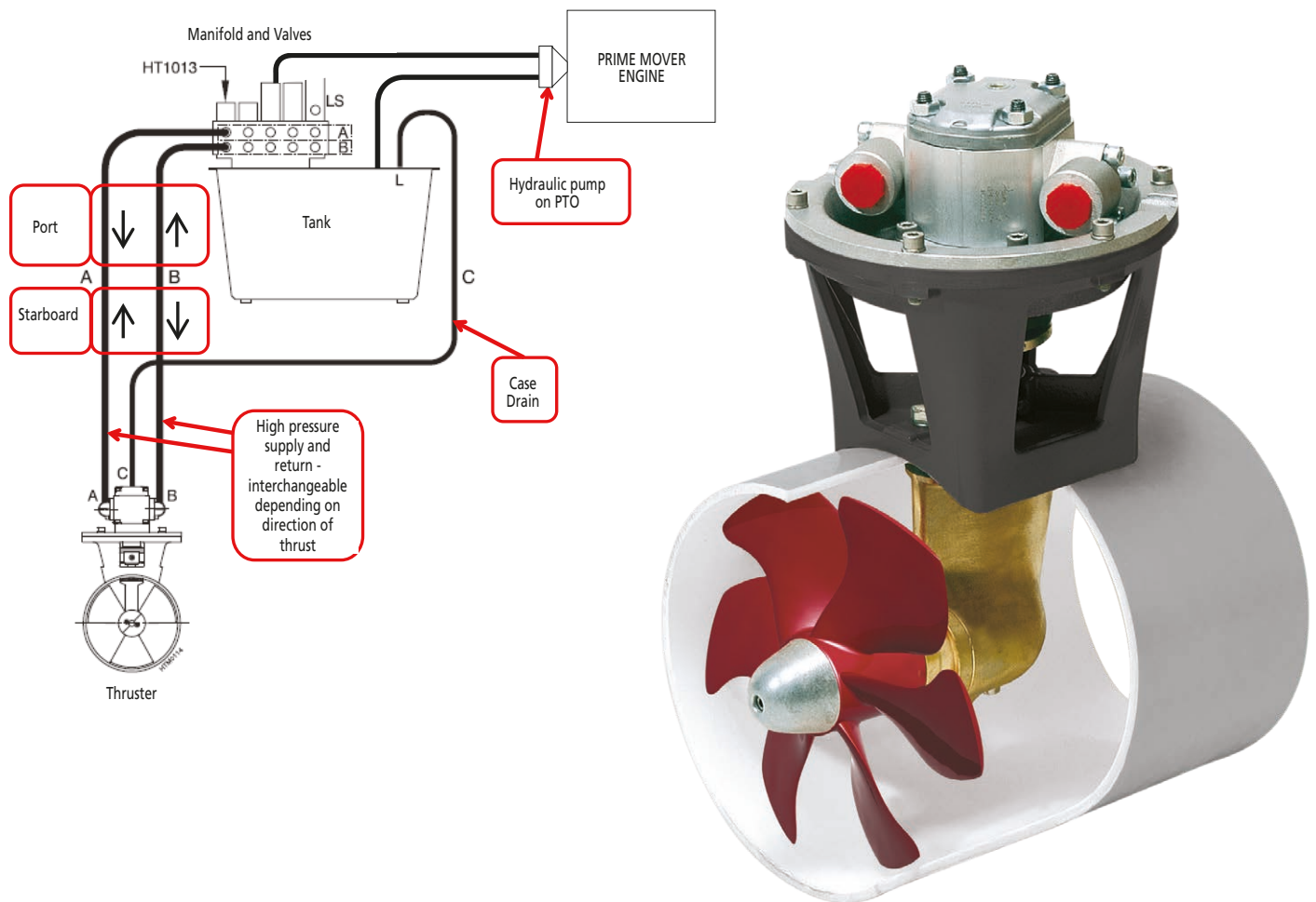

BOW..HMD

HYDRAULIC BOW AND STERN THRUSTERS

Type	Specifications
BOW55HMD	Hydraulic bow thruster 121 lbf (55 kgf) incl. hydro motor 3,5 kW, for tunnel diam. 5 ²⁹ / ₃₂ " (150 mm)
BOW95HMD	Hydraulic bow thruster 210 lbf (95 kgf) incl. hydro motor 6,0 kW, for tunnel diam. 7 ⁹ / ₃₂ " (185 mm)
BOW160HMD	Hydraulic bow thruster 352 lbf (160 kgf) incl. hydro motor 12,3 kW, for tunnel diam. 9 ⁷ / ₈ " (250 mm)
BOW230HMD	Hydraulic bow thruster 507 lbf (230 kgf) incl. hydro motor 16,4 kW, for tunnel diam. 11 ¹³ / ₁₆ " (300 mm)
BOW310HMD	Hydraulic bow thruster 665 lbf (310 kgf) incl. hydro motor 26,8 kW, for tunnel diam. 11 ¹³ / ₁₆ " (300 mm)
BP1053	Bronze propeller for BOW22024/BOW230HM
BP1182	Bronze propeller for BOW300HM/310HM

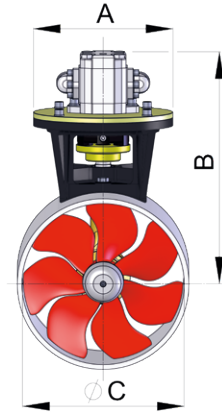

Specifications	BOW55HMD	BOW95HMD	BOW160HMD	BOW230HMD	BOW310HMD
Thrust N (kgf)	550 (55)	950 (95)	1600 (160)	2300 (230)	3100 (310)
Hydraulic motor power kW	3,5	6,0	12,3	16,4	26,8
Hydraulic motor speed rpm	3000	4100	3730	2540	2760
Hydraulic motor capacity cm ³ /rev	4,2	4,2	8,4	16,8	27
Flow rate l/min	13	18	28	40	70
Operating pressure bar	165	230	260	245	230
Internal tunnel diameter inches (mm)	5 ²⁹ / ₃₂ (150)	7 ⁹ / ₃₂ (185)	9 ²⁷ / ₃₂ (250)	11 ¹³ / ₁₆ (300)	11 ¹³ / ₁₆ (300)
A Ø inches (mm)	6 ⁵ / ₁₆ (160)	7 ⁷ / ₈ " (200)	9 ⁷ / ₁₆ (240)	10 ⁵ / ₃₂ (258)	10 ⁵ / ₃₂ (258)
B inches (mm)	10 ⁵ / ₃₂ (258)	10 ⁷ / ₈ (276)	13 ¹⁹ / ₃₂ (345)	17 (431)	17 ²⁹ / ₃₂ (455)
C Ø inches (mm)	5 ²⁹ / ₃₂ (150)	7 ⁹ / ₃₂ (185)	9 ⁷ / ₈ (250)	11 ¹³ / ₁₆ (300)	11 ¹³ / ₁₆ (300)

Type BOW410HM - BOW550HM

The hydraulic motor for types BOW410HM and BOW550HM is located within the tailpiece.

BOW410HM

BOW550HM

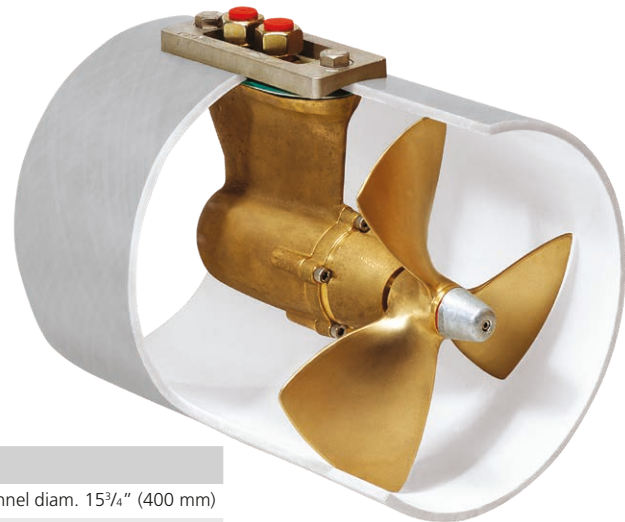

Type	Specifications
BOW410HM	Hydraulic bow thruster 410 kgf, incl. hydro motor 22 kW, for tunnel diam. 15 ³ / ₄ " (400 mm)
BOW550HM	Hydraulic bow thruster 550 kgf, incl. hydro motor 33 kW, for tunnel diam. 15 ³ / ₄ " (400 mm)
BP1259	Bronze propeller for BOW410HM
BP1260	Bronze propeller for BOW550HM

Specifications	BOW410HM	BOW550HM
Thrust, N (kgf)	4100 (410)	5500 (550)
Hydraulic motor power, hp (kW)	30 (22)	45 (33)
Hydraulic motor speed, rpm	1920	1920
Hydraulic motor capacity, in ³ /rev (cm ³ /rev)	2.75 (45)	2.75 (45)
Flow rate, gal/min	24 (92)	24 (92)
Operating pressure, psi	2610 (180)	4061 (280)
Internal tunnel diameter inches (mm)	15 ³ / ₄ (400)	15 ³ / ₄ (400)

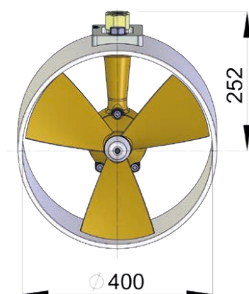
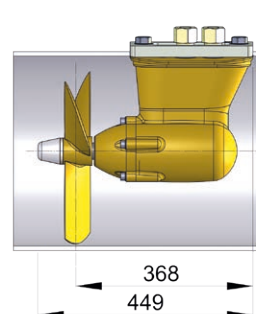

STABILIZERS (HYDRAULIC)

Motor yachts over 10 metre length are frequently used on open waters. VETUS stabilizers are the ideal solution for dramatically reducing the rolling movement of these vessels in bad weather or in heavy swells.

Stabilizers consist of a hydraulically actuated pair of fins that are fitted to a vessel's port and starboard midships sections underwater. They are controlled by an on board gyroscope and electronics and automatically react to the rolling movement of the vessel to create a damping effect. In other words, rolling motion is reduced considerably by the use of VETUS stabilizers, resulting in increased comfort and reduced risk of seasickness.

Stabilizers can to some extent, be compared with an aircraft's ailerons, which considerably reduces movement in bad weather.



Valve block



How do they work?

The stock for each stabilizer fin is controlled by a set of hydraulic cylinders. These hydraulic cylinders are operated by the on board hydraulic system, powered by the main engine(s) or generator set. A gyroscope detects vessel movement and electronics and a valve block control oil flow to the cylinders, generating a movement in the fins to counter the roll. The valve block contains a solenoid valve controlling the direction of the fins, a centering valve for when going astern and an oil pressure control unit.

Hydraulic hoses connect the hydraulic pump, the valve block and the hydraulic cylinders. If there is no hydraulic system already on board, then VETUS can also supply the components for this.

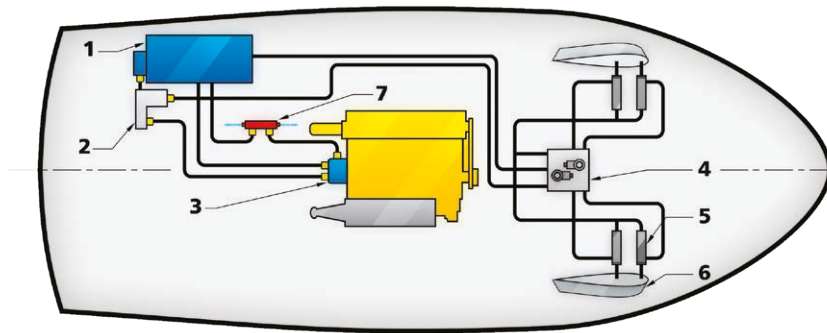

1. Stainless steel tank with oil cooler
2. Connection for secondary drive
3. Hydraulic pump
4. Valve block
5. Stabilizer cylinders
6. Stabilizer fin
7. Oil cooler

3 Possibilities

1. A boat equipped with a VETUS hydraulic installation (stabilisers can always be added)
2. A boat equipped with a hydraulic installation not supplied by VETUS (it is always possible to add stabilisers with a custom made modification, please consult VETUS).
3. A boat without a hydraulic installation; use a stand-alone system.

STABILISERS STAND ALONE SYSTEM WITH SMALL GEAR PUMP AND SMALL HYDRAULIC TANK

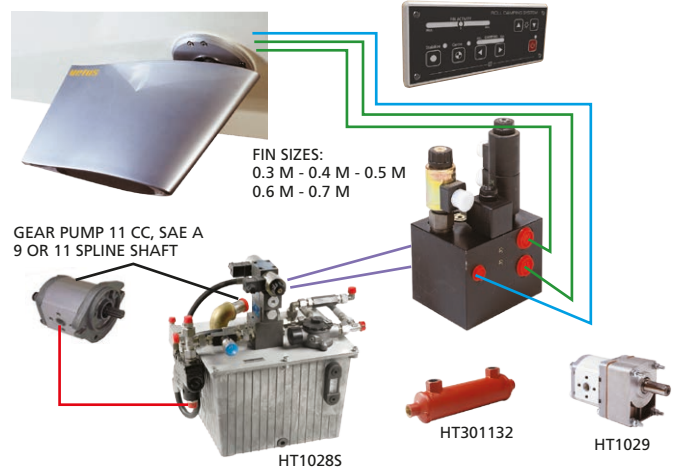

STABILIZERS (HYDRAULIC)

Do they affect the speed?

In smooth water with the stabilizers not in use, the speed reduction is negligible (for example: about 1 knot at 25 knots for a 82 feet (25 metre) vessel). In heavy seas however, a vessel using stabilizers has the advantage, because the boat rolls less and therefore has a lower wetted surface area.

Which size?

- B = The waterline beam in metres.
 D = The displacement in metric tons.
 T = The roll period in seconds. This is the time taken to roll from starboard to port and back to starboard again. The amplitude is not important here since the roll period always remains constant. The roll period can therefore be measured fairly easily by causing the vessel to roll gently when moored alongside the quay.
 V = The cruising speed in knots.

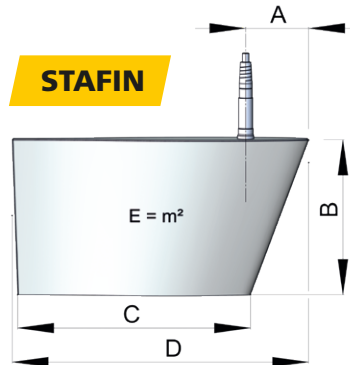

The fin size can be calculated using the following formula:

$$\text{Fin surface in m}^2 = \frac{3,5 \times B \times D}{T^2 \times V^2}$$

The recommended fin size is as follows:
 $\frac{3,5 \times 3,6 \times 23}{3,5^2 \times 8,5^2} = 0,33 \text{ m}^2$

Thus, a fin size of 0.4 m² should be chosen or 0.3 m² if space is restricted.

	03	04	05	06	07
A	5 19/32"	6 59/64"	8 15/32"	9 27/32"	11 29/64"
B	16 31/32"	9 9/16"	21 13/16"	23 5/8"	23 13/16"
C	24 13/32"	28 3/16"	31 17/32"	34 3/8"	40 13/64"
D	31 27/64"	36 17/64"	40 5/16"	44 19/64"	51 57/64"
E	1/64"	1/64"	1/64"	1/32"	1/32"

Example

A 44.2 ft (13.5 m) motor yacht has waterline beam of 11.8 ft (3.6 metre). The displacement is 23 metric tons and the cruising speed is 8.5 knots. Roll period is 3.5 sec.

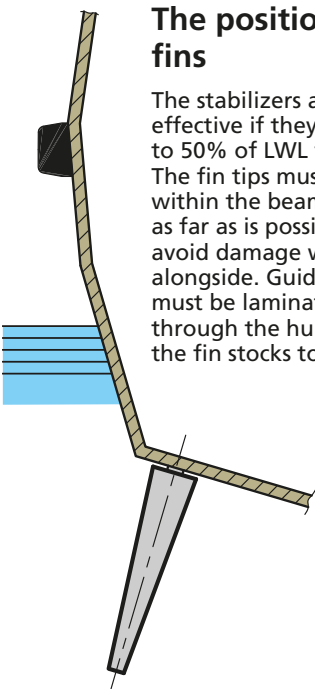

The position of the fins

The stabilizers are most effective if they are located 40 to 50% of LWL from the bow. The fin tips must be located within the beam of the vessel as far as is possible, so as to avoid damage when mooring alongside. Guide bushes must be laminated or welded through the hull sections for the fin stocks to pass through.

Scope of supply

STA24VA consisting of four hydraulic cylinders with associated valve block, a control panel and a solid-state gyroscope (which registers the vessels movement). The standard power supply is 24 Volt DC (a 12 Volt to 24 Volt transformer is available as an option).

A pair of fins. The stock and blade are made from stainless steel and the blade is filled with polyurethane. There is a choice of 5 fin sizes available: 0.3, 0.4, 0.5, 0.6 and 0.7m².

A pair of guide bushes, available for steel, GRP or aluminum hulls. The high pressure hoses are not included and should be ordered separately to the required lengths.

VETUS stabilisers overview

- "Plug and Play" installation for steel, GRP and aluminum vessels
- Fully automatic operation
- The fin movement is automatically adjusted according to the degree of damping selected, the speed of the vessel and the sea state
- All electronic components are solid state



STA24VA

From the control panel the stabilizers can be switched on or off or centered for when going astern. The required amount of damping can be adjusted and the roll amplitude is displayed.

Specifications

- Dimensions: 8 1/4" x 3 11/32" x 4" (210 x 85 x 103 mm)
- Meets the EMC requirements



HYDRAULIC POWER STEERING

For larger boats, VETUS hydraulic power steering is a most comfortable and extremely safe steering system. The effort required at the helm is only about 10% of a non-powered steering system. In other words: the boat can be steered literally with one finger. Because of this, the steering wheel diameter can be considerably smaller than normal; a wheel diameter of just 14^{11/64}" (360 mm) will usually suffice.



HT1018

HT1020

HT1025

VETUS hydraulic power steering is extremely safe. Should there be a power assistance failure, then the steering system will still operate unassisted, only with somewhat greater effort. The pump unit is in fact a rotating proportional valve. By turning the wheel, this control valve opens and directs oil under pressure to the steering cylinder connected to the rudder. The volume of hydraulic fluid that is circulated, is dependent on the model of steering pump, the number of wheel revolutions and the speed at which the wheel is turned. The VETUS steering pump has a closed mid position, ensuring that there will be no oil flow as long as the wheel remains untouched. To connect one or more VETUS steering pumps and/or an automatic pilot to a VETUS hydraulic system, a control unit model HT 1019 must be used.

The external flange of the steering pump is made of seawater resistant aluminium, hand polished and anodised. The steering wheel shaft is made of stainless steel, type I-4462, Ø 3/4" (19 mm), taper 1:12.

The VETUS hydraulic power steering has been developed for application within the "VETUS Power Hydraulics" programme, which is based on the "constant pressure" (load sensing) principle. If your boat is equipped with a hydraulic system which does not operate on this principle, VETUS will gladly advise on how to adapt your system, in order to enable installation of this type of steering.

Type	Specifications
HT1020	Hydraulic power steering 4.6 in ³ /rev for cylinders up to MTC175
HT1018	Hydraulic power steering 5.8 in ³ /rev for cylinders up to MT230
HT1025	Hydraulic power steering 8.8 in ³ /rev for cylinders up to MT345
HT1019	Steering and control unit for hydraulic power steering and autopilot
HT1021	Dual non-return valve for hydraulic power steering

HT1019

Solenoid control unit (24 Volt) for use with a hydraulically powered steering system or an automatic pilot.

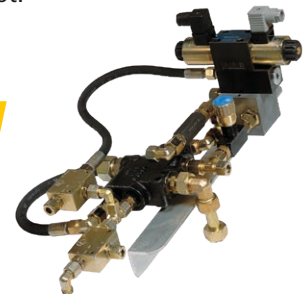

HT1019

Schematic based on Fixed Pump

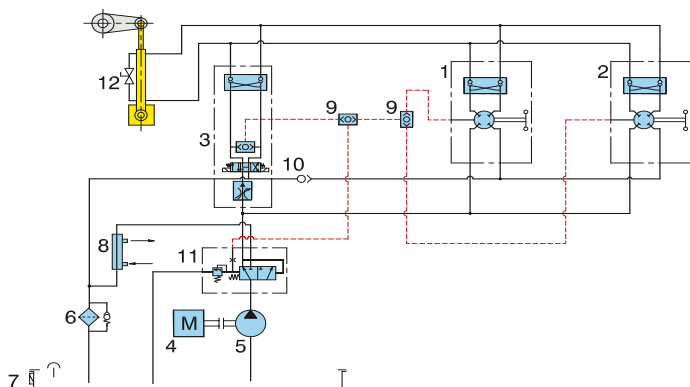

1. Steering pump with non-return valve
2. Steering pump with non-return valve (second steering position)
3. Control unit
4. Propulsion engine
5. Hydraulic pump
6. Filter
7. Hydraulic tank
8. Oil cooler
9. Shuttle valve
10. Non-return valve
11. Priority valve
12. Cylinder with by-pass

HYDRAULIC POWER STEERING



The size of the cylinder is determined according to the rudder torque.

Pump type Assuming 4 – 6 steering wheel revolutions from port to starboard	Cylinder volume in in ³	VETUS cylinder model	Oil flow to steering pump gallon/min.	Pipe diameter mm
HT1020 (4.6 in ³ /rev.)	18.3 to 27.5 in ³	up to MTC175	7.9 gal./min.	Ø 10 mm
HT1018 (5.8 in ³ /rev.)	23.2 to 34.8 in ³	up to MT230	7.9 gal./min.	Ø 18 mm
HT1025 (8.8 in ³ /rev.)	35.4 to 53.1 in ³	up to MT345	7.9 gal./min.	Ø 18 mm

Hydraulic pump type HT1029

Although the engine manufacturer will often supply the hydraulic pump, VETUS can also offer a fixed volume hydraulic pump, which is belt driven off the main engine. This pump can be used in conjunction with our hydraulic power steering.

This VETUS pump has a built in bearing block. Its dimensions are small and are comparable with those of the alternator. The pump has a power take-off of approximately 1 kW (1.5 hp).

- Dimensions (l x w x h): 8^{21/32}" x 3^{9/16}" x 4^{7/16}" (220 x 90 x 112 mm)
- Weight: 11 lbs (5 kg)
- Shaft diameter: ⁵⁵/₆₄" (22 mm)
- Maximum shaft speed: 3,500 rpm
- Suction and pressure connections are included.

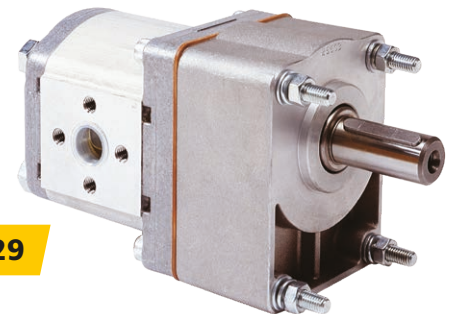

HT1029

If an existing engine driven pump is to be used, the hydraulic flow rate must be minimum 1.8 gal./min (7 l/min) and maximum 10.5 gal./min (40 l/min), with a maximum working pressure of 1015 psi.

POWER STEERING STAND ALONE SYSTEM WITH SMALL GEAR PUMP AND SMALL HYDRAULIC TANK

3 Possibilities

1. A boat equipped with a VETUS hydraulic installation (a hydraulic power steering system can always be added)
2. A boat equipped with a hydraulic installation not supplied by VETUS (it is always possible to add a hydraulic power steering system with a custom made modification, please consult VETUS).
3. A boat without a hydraulic installation; use a stand-alone system.

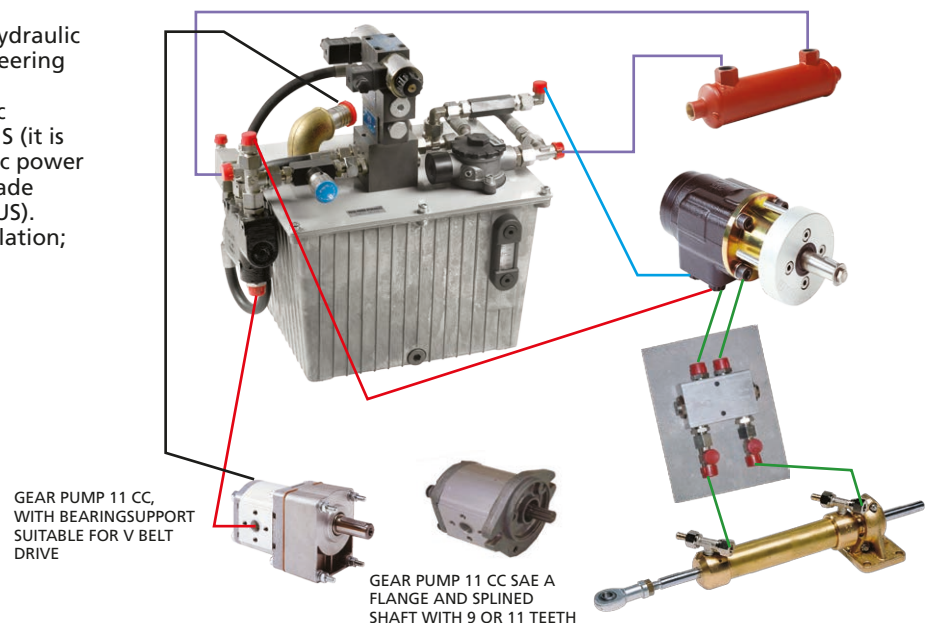

HYDRAULIC POWER STEERING

Electro-hydraulic pumps with continuous running DC-motor (DC Powerpacks)

These DC Powerpacks can be used as an alternative for a main engine driven pump in an hydraulic power steering system.

DC Power Packs can also be used as an extra pump in an hydraulic system where a pump is already installed on the propulsion engine. For example, a deck hatch can then be opened or closed even when the main engine is not running.

Available for 12 Volt with a 500 W motor and for 24 Volt with an 1100 W motor.



Oil cooler type HT3011

If a pump with a fixed swept volume, or a high capacity is installed, or if the ambient temperature is high, a lot of heat can be generated. In these cases, the installation of an oil cooler in the return line will be required.

Four different cooling water hose diameters are available:

- Ø 1¹/₄" (32 mm) (HT301132)
- Ø 1¹/₁₆" (42 mm) (HT301142)
- Ø 1²⁷/₃₂" (47 mm) (HT301147)
- Ø 2" thread (HT3011MP)



HT3011MP

Small hydraulic tank type HT1028

VETUS power steering can be connected to an existing on board hydraulic system. However, if one is not fitted and only power steering is required, this small hydraulic tank (contents about 70 gallons (18 litres)) will be sufficient. The tank comes complete with all the necessary control components mounted on the top.

Dimensions of the tank

- Length 18⁷/₆₄" (460 mm)
- Width 11¹³/₁₆" (300 mm)
- Height 18¹/₂" (470 mm)

Type	Specifications
HT1028	Hydraulic tank for power steering (complete)
HT1029	Hydraulic pump with bearing block, 11.3 cm ³ /rev
HT301132	Hydraulic oil cooler for hose ID Ø 1 ¹⁷ / ₆₄ " (32 mm)
HT301142	Hydraulic oil cooler for hose ID Ø 1 ²¹ / ₃₂ " (42 mm)
HT301147	Hydraulic oil cooler for hose ID Ø 1 ²⁷ / ₃₂ " (47 mm)
HT3011MP	Oil cooler, 2" BSP



HT1028

HYDRAULIC PROPULSION

In many cases it may be preferable to drive the propeller shaft by means of a hydraulic motor, instead of using the conventional set up of engine and gearbox.

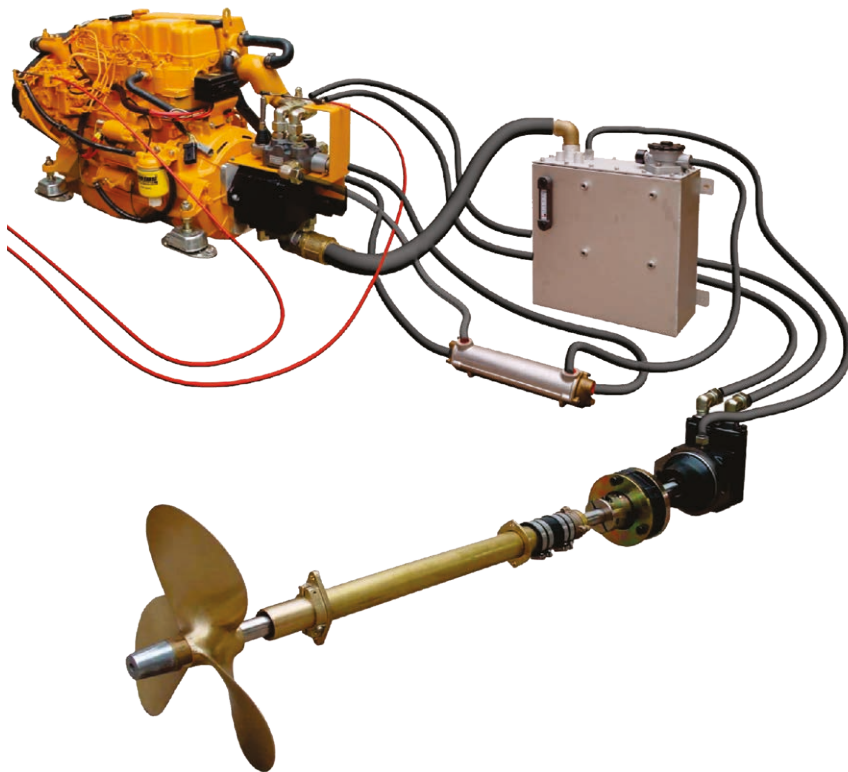

How it works

A hydraulic vane pump is fitted to the engine in place of the gearbox. This pump draws hydraulic fluid from a storage tank and delivers it under pressure to the speed and direction control valve. The control valve determines the direction and volume of hydraulic flow to the hydraulic vane motor, which can then rotate clockwise or counter clockwise as selected. This hydraulic motor drives the propeller shaft via a flexible coupling.

The VETUS system uses a hydraulic pump and motor with fixed swept volumes. The transmission ratios (reduction) in the propulsion system are achieved by the difference in volume between the vane pump and the hydraulic motor.

The reduction between the engine RPM and the shaft RPM is 2:1 for models HPM4.35, HPM4.45 and HPM4.56 and 1.9:1 for model HPH4.65. The maximum permissible engine power is 50 kW (67 HP), with a maximum engine speed of 3,000 RPM. In most cases a shaft diameter \varnothing 1" (25 mm) will suffice. The output flange of the VETUS hydraulic motor fits all VETUS flexible couplings.

Scope of supply

VETUS hydraulic propulsion is available in 4 versions:

Model HPM4.35 has a VETUS M4.35 marine diesel engine of 24.3 kW (33 hp).

Model HPM4.45 has a VETUS M4.45 marine diesel engine of 30.9 kW (42 hp).

Model HPM4.56 has a VETUS M4.56 marine diesel engine of 38 kW (52 hp).

Model HPH4.65 has a VETUS VH4.65 marine diesel engine of 48 kW (65 hp).

VETUS hydraulic vane motor



Stainless steel storage tank



VETUS hydraulic vane pump



All versions include

- VETUS marine diesel engine as selected
- Hydraulic vane pump
- Adapter flange and coupling to fit the pump to the relevant engine
- Hydraulic vane motor
- 9.25 gal. hydraulic oil tank
- Oil cooler
- Control valve
- Flexible engine mounts
- Engine instrument panel and loom

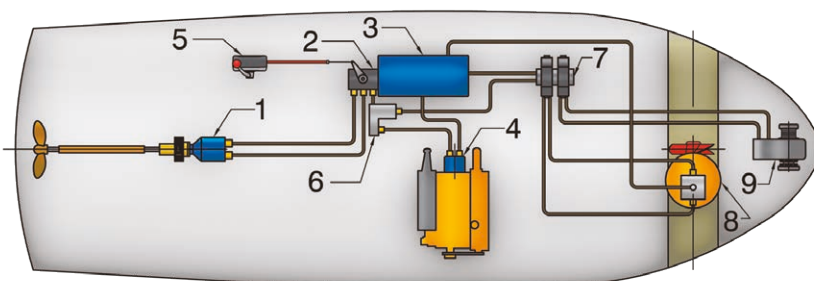

Example System

1. Hydraulic vane motor
2. Mechanically operated control valve
3. Stainless steel storage tank
4. Hydraulic vane pump
5. Remote control handle with cable
6. Connection for ancillary devices
7. Control unit for ancillary devices
8. Bow thruster
9. Anchor windlass

HYDRAULIC PROPULSION SYSTEM (HPS)

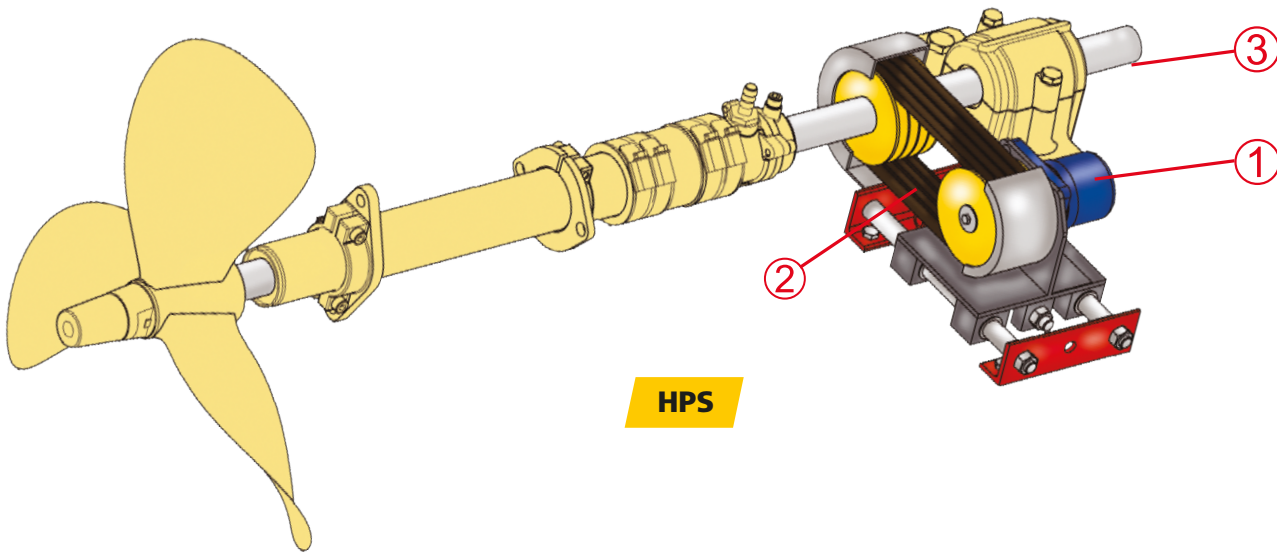

HPS

The VETUS diesel-hydraulic propulsion system can be used to propel the boat at very low speeds on inland waterways where wash is detrimental to the environment or when low trolling speeds are required. Of course, it can also be used as an emergency propulsion system, in case of main engine trouble. The propulsion system may only be used with propeller shafts that have a separate thrust bearing.

The VETUS diesel-hydraulic propulsion system consists of a hydraulic motor, which is capable of producing high radial output power, that is to say, rotating slowly but with a high torque. The required power to drive the hydraulic motor can be provided by a "Powerpack" (an engine with a hydraulic pump attached) or by a generator set with an integrated hydraulic pump. The hydraulic oil flow is regulated proportionally, which means that the propeller shaft can start turning extremely slowly and that speed is built up gradually.

This hydraulic motor ① drives the propeller shaft ③ by means of a "Power Band" ②. In this case the power band consists of 4 V-belts, vulcanized to a flat belt, forming a complete band. The hydraulic motor is mounted on a frame that can be moved on a rail, by means of a hydraulic cylinder. When not in use, the power band will be slack and hang loosely over the propeller shaft pulley under its protective cover. When the hydraulic cylinder is activated, the power band is tensioned around both pulleys, thus creating mechanical transmission between the hydraulic motor and the propeller shaft.

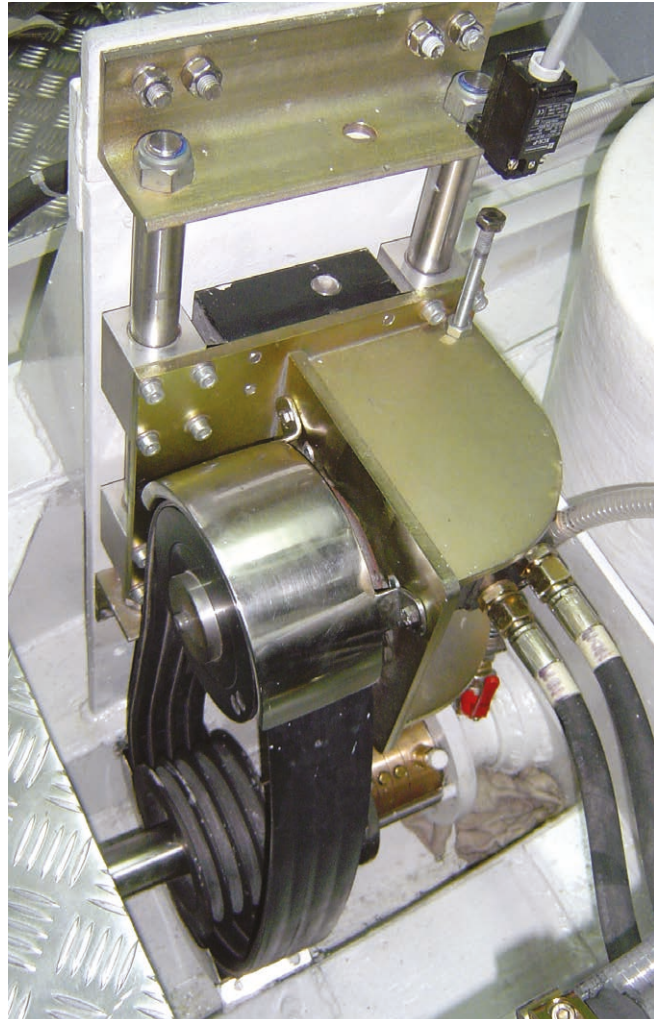

ELECTRIC POWER PACKS, 12 AND 24 VOLT

Most VETUS power hydraulics systems are designed to run from an engine driven hydraulic pump. With such a system on board, there can be enough power to operate many different pieces of hydraulic equipment such as bow and stern thrusters, power steering, anchor windlass, capstan, gangway etc. However, these devices can only operate when the main engine or generator are running, depending on where the pump is powered from. In certain circumstances though, it may be desirable to operate the hydraulic systems without the engine or generator running. In these cases, a VETUS electric power pack will provide the answer: either as a stand alone system or, as an additional power source in the main power hydraulics system. The electric power packs meets the EMC requirements.

These power packs can be supplied in various executions: 12 or 24 Volt D.C and with different power capacities, pump outputs, tank capacities, etc. They may also be supplied without the tank, in which case the system should be connected to the main hydraulic tank on board.

The power pack can be used to operate a maximum of 4 functions. In the example shown here, the power pack is equipped with 4 NG6 base plates, to which standard VETUS solenoid control units may be connected (HT1014, HT102311, HT102312).

For electrical operation of the power pack and the control units, VETUS junction box HT5034 is required together with one or more switches.

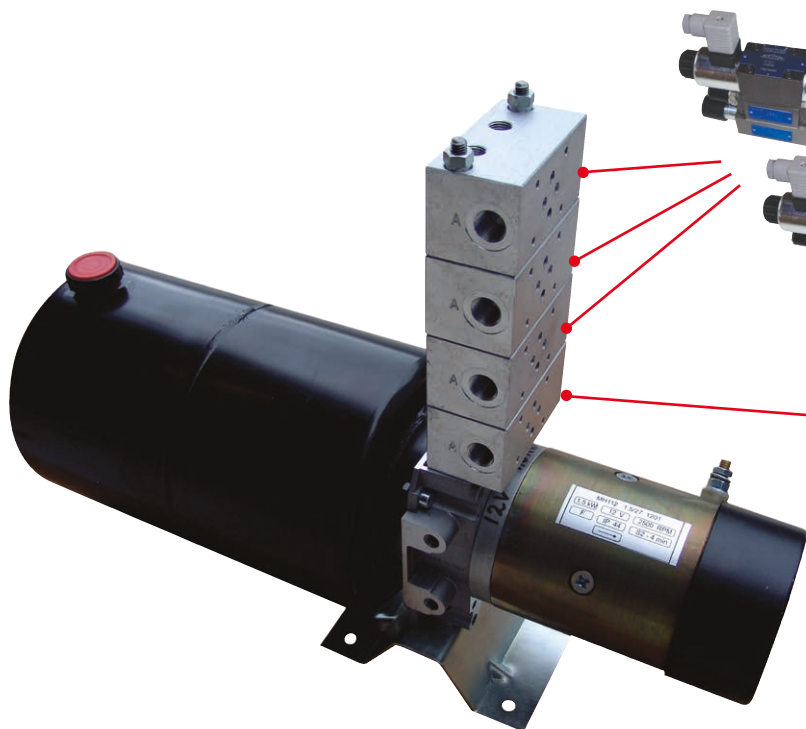
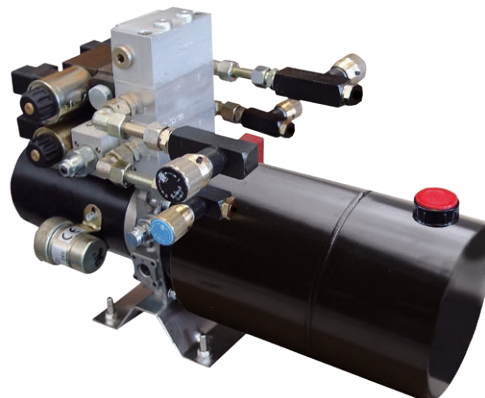

HT102311

HT102312



HT1014



HT1047

Auxiliary DC PowerPack
24V, 3000 W. No reservoir included

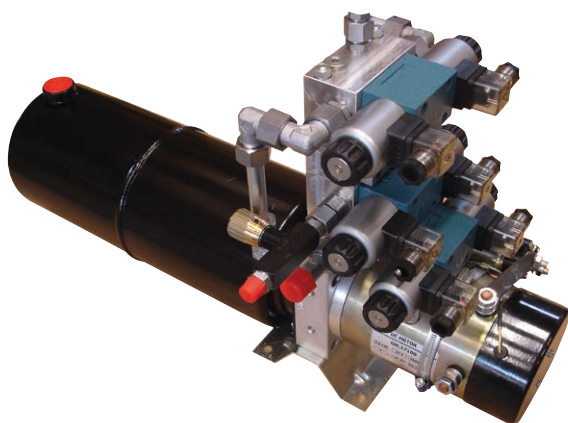

HT5034

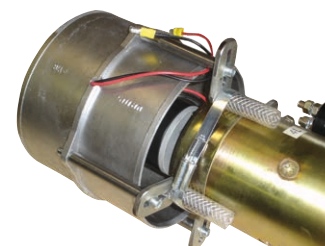

Forced air cooler DC Power Pack





HYDRAULIC WINDLASSES

These hydraulic windlasses and capstans are powered by a gerotor type hydraulic motor with a two high pressure ports. No separate case drain is required.

No electrical connections are required at the windlass or capstan. All electrical control connections are made at the control valves, most frequently located at the hydraulic reservoir tank, in or near the engine room.

Hydraulic port sizes and hydraulic hose type and diameters will be provided by your VETUS hydraulic support engineer.

As with all Maxwell windlasses, the maximum pull should equal or exceed three times the total weight of the ground tackle (chain and anchor).

Please see the Maxwell windlass section of this catalogue for details of the chainwheel and warping drums, as these are common to both electric and hydraulic windlasses. In that catalogue section you will also find information about bow rollers, chain stoppers, anchors, chains, rodes and many other anchoring system components.



Maxwell hydraulic windlasses and capstans

Type Windlass	Maximum Pull		Chain size if applicable inch - mm	Rope size if applicable inch - mm	Hydraulic Flow		Hydraulic Pressure		Weight - topworks, gearbox, motor	
	Kg	Pounds			Litres/minute	US. Gallons/minute	bar	psi	Kg	Pounds
RC8-8	600	1320	5/16 - 8	5/8 - 16	20	5.3	138	2000	10.5	23
RC10-8	700	1540	5/16 - 8	5/8 - 16	20	5.3	138	2000	13.6	30
RC10-10	850	1870	3/8 - 10	5/8 - 16	20	5.3	138	2000	14	31
RC12-10	1134	2500	3/8 - 10/11	5/8- 3/4-16/20	42	11	138	2000	26	57
RC12-12	1590	3500	1/2 -12/13	3/4 - 20	42	11	138	2000	26	57
HRC10-8	700	1540	5/16 - 8	5/8 - 16	20	5.3	138	2000	13	28.5
HRC10-10	850	1870	3/8 - 10	5/8 - 16	20	5.3	138	2000	13	28.5
VC1000	700	1540	N/A		20	5.3	100	1450	11	24
VW1000	700	1540	1/4 to 3/8 - 6- 10		20	5.3	100	1450	15	33
VW1500	850	1870	1/4 to 3/8 - 6- 10		20	5.3	138	2000	15	33
VW2500	1135	2500	5/16 to 3/8 -9-11		36	9.5	138	2000	32	70.5
VW3500	1590	3500	3/8 to 1/2 -10-13		42	11	138	2000	40	88
VWC1000	700	1540	1/4 to 3/8 - 6- 10		20	5.3	100	1450	17	37
VWC1500	850	1870	1/4 to 3/8 - 6- 10		20	5.3	138	2000	17	37
VWC2500	1135	2500	5/16 to 3/8 -9-11		36	9.5	138	2000	32	70.5
VWC2500 Tall Drum	1135	2500	5/16 to 3/8 -9-11		36	9.5	138	2000	32	70.5
VWC3500	1590	3500	3/8 to 1/2 -10-13		42	11	138	2000	40	88
HWC2500	1135	2500	5/16 to 3/8 -9-11		36	9.5	138	2000	48.5	107
HWC3500	1590	3500	3/8 to 1/2 -10-13		40	10.6	138	2000	49	108



ELECTRICITY ON BOARD

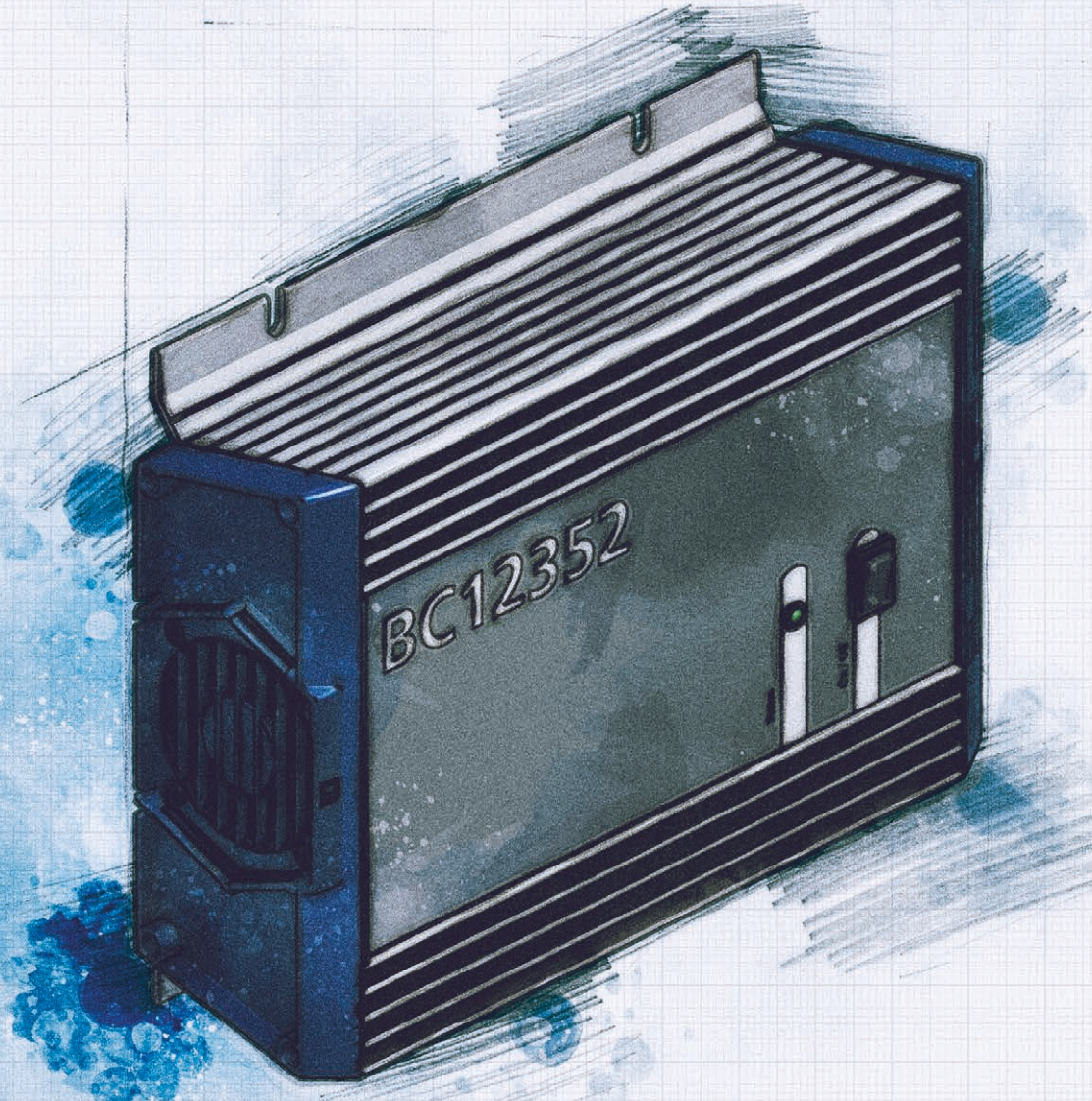

- 
- 
- 
- 
- 
- 
- 
- 
- 
- 
- 
- 
- 
- 
- 

Overview VETUS electricity on board

Diesel generators see page 223



Inverters see page 225



Battery chargers see page 227



Battery charger/maintainer see page 228



Battery splitters see page 228



Batteries see page 229



Automatic change-over device

see page 231



Shore power protector see page 231



Solar charger see page 231



Accessories see page 232



ELECTRICITY ON BOARD

Electricity on board not only has an important role in creating comfortable living conditions, but also plays a vital part in safe operations. A pleasant stay on board is dependent on reliable electrical power. VETUS supplies a wide range of products that will exceed your expectations when it comes to electricity on board. Whenever you need power, you can rely on VETUS.

VETUS offers the following electrical system components

Generator sets

When high capacity power supply is needed. All VETUS generators are supplied as standard with a complete exhaust and water intake system and a remote control panel.

Batteries

VETUS offers 3 different types of batteries: The SMF (Sealed Maintenance Free), AGM (Absorbed Glass Mat) and the Deep Cycle marine battery series. These very low self discharge batteries are designed to live up to the varying seasonal demands on a battery which is used on board.

Battery chargers and splitters

Providing optimum simultaneous charging with lower cost, faster installation time, fewer cables and more space.

Inverters

Compact and lightweight inverters to power many items of electrical and electronic equipment.

Solar charger

Popular supplement to the charging system on boats. Economical and environmentally friendly way to top up your on board power supply. Can be used as a stand-alone charger or in combination with the Combi-gamma charger/inverter.

Why VETUS electricity on board

Below we have highlighted a few good reasons to consider VETUS electricity on board

- All VETUS electricity on board products meet the EMC requirements
- The Combi-gamma has a load support function which regulates all the supply sources
- A power protection device prevents overloading the shore supply or generator
- Uninterrupted power supply (UPS) switches in the inverter in case of generator failure
- Exceptionally quiet generators supplied with auto demand start as standard

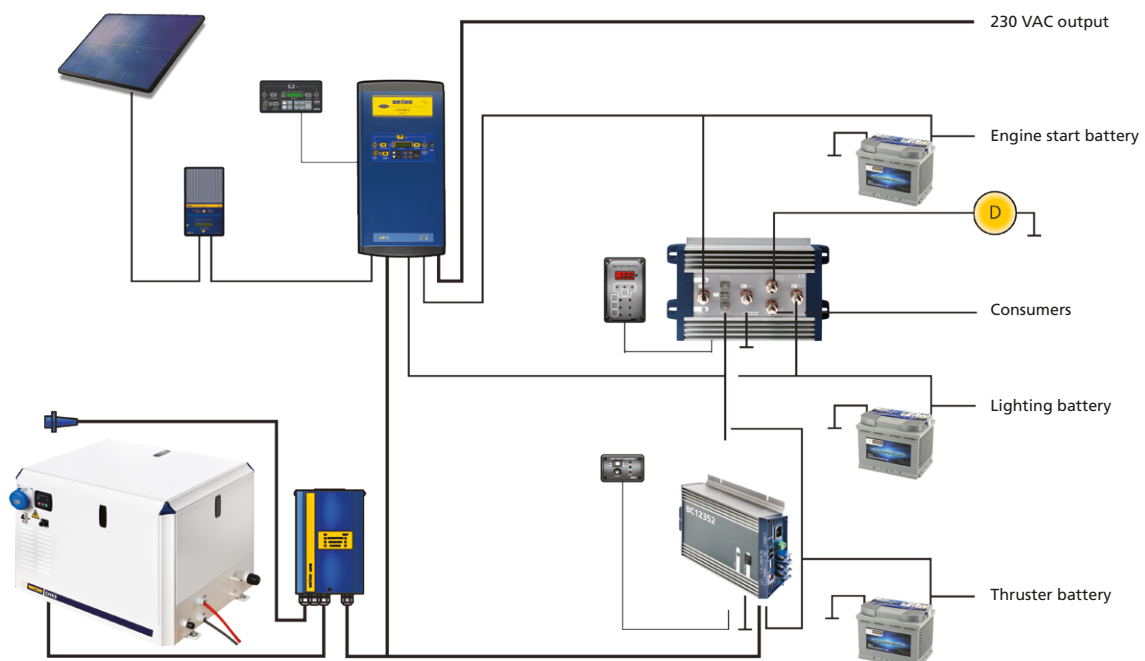

DIESEL GENERATOR SETS

GX series generator sets

Reliable, easy to maintain and exceptionally quiet!

VETUS GX generators range from 6 kVA to 20 kVA and are available in a choice of 50 or 60 Hertz outputs. The base engines are carefully selected for power output and fuel economy, depending on the speed and output of the generator to be driven.

These generator sets operate at either high or low fixed engine speeds and can be placed even in the most confined spaces because of their compact dimensions and lower weight. The high quality of design, insulation and finish of the generators used in this range, guarantee a long reliable life time.

Characteristics

- Reliable, highly fuel efficient engines are used - marinised in-house!
- Sturdy aluminium engine cover acts as a sound barrier and thermal insulator
- Very clean sine wave, low signal noise < 3% and overload protected
- Easy installation and maintenance - high serviceability!
- Pre-installed connections for battery cables, fuel supply / return, exhaust and raw water
- Comes with a remote control panel (MPRGEN) including six metre cable

Specifications

- Generator sets from 6 kVA to 20 kVA
- 50 or 60 Hertz output
- High speed (3000 / 3600 rpm) and low speed (1500 / 1800 rpm) types available
- Single phase (120 - 230 V) and three phase (240 - 400 V)
- Maximum voltage variance: plus or minus 2%
- Protection: IP55
- Max. ambient temperature: 40°C
- Max. raw water temperature: 30°C
- Noise level (GLX) with sound-proof box: 57 dB(A)
- Noise level (GHX) with sound-proof box: 65 dB(A) / 68 dB(A)
- Max. cont. angle of inclination:
fore and aft: 15° athwartships: 25°

All GX generator sets are supplied with a digital control panel. This panel feature an auto demand function to start the generator whenever AC power is required.



MPRGEN

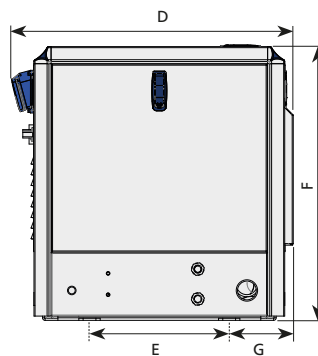
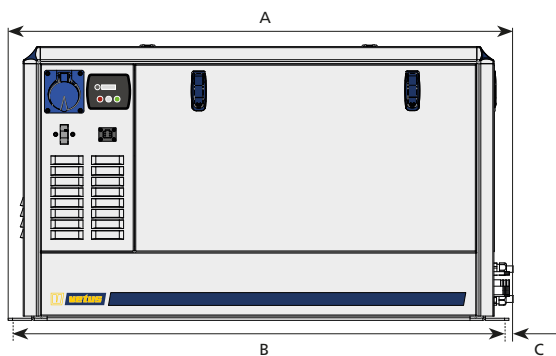

Dimensions

	GLX 6/7 SIC/TIC	GHX 8/9 SIC/TIC	GHX 14/17 SIC	GHX 14/17 TIC	GLX 14/17 SIC	GLX 14/17 TIC	GLX 20/24 TIC
A (mm)	927	884	1082	1082	1172	1172	1292
B (mm)	887	844	1042	1042	1132	1132	1332
C (mm)	20	20	20	20	20	20	20
D (mm)	657	659	659	659	659	659	739
E (mm)	297	327	327	327	327	327	407
F (mm)	644	571	641	641	641	641	694
G (mm)	165	150	150	150	150	150	150



DIESEL GENERATOR SETS

Type	Power kVA	Engine speed (rpm)	Frequency (Hz)	Phase	Voltage	Weight lbs (kg)	Engine type
50 Hertz							
GHX8SIC	8	3000	50	Single	230	408 (185)	M2.18
GHX8TIC	8	3000	50	Three	3 x 230/400	408 (185)	M2.18
GHX14SIC	14	3000	50	Single	230	630 (295)	M3.29
GHX14TIC	14	3000	50	Three	3 x 230/400	630 (295)	M3.29
60 Hertz							
GLX6,5SIC	6	1500	50	Single	115 or 230	540 (245)	M3.29
GLX6,5TIC	6	1500	50	Three	3 x 230/400	540 (245)	M3.29
GLX14SIC	14	1500	50	Single	115 or 230	871 (395)	M4.45
GLX14TIC	14	1500	50	Three	3 x 230/400	871 (395)	M4.45
GLX20TIC NEW	20	1500	50	Three	3 x 230/400	n.a.	VH4.65
60 Hertz							
GHX9SIC	9	3600	60	Single	120 or 240	408 (185)	M2.18
GHX9TIC	9	3600	60	Three	3 x 240/415	408 (185)	M2.18
GHX17SIC	17	3600	60	Single	120 or 240	630 (295)	M3.29
GHX17TIC	17	3600	60	Three	3 x 240/415	630 (295)	M3.29
GLX7SIC	7	1800	60	Single	120 or 240	540 (245)	M3.29
GLX7TIC	7	1800	60	Three	3 x 240/415	540 (245)	M3.29
GLX17SIC	17	1800	60	Single	120 or 240	871 (395)	M4.45
GLX17TIC	17	1800	60	Three	3 x 240/415	871 (395)	M4.45
GLX24TIC NEW	24	1800	60	Three	3 x 240/415	n.a.	VH4.65

Other voltages on request.

Further developments

GHX4/5

VETUS is working on a small 4kVA, 50 Hz (5kVA, 60 Hz) generator set which will have the same design and characteristics as the other GX generators.

Please check our website www.vetus.com regularly for the latest update.

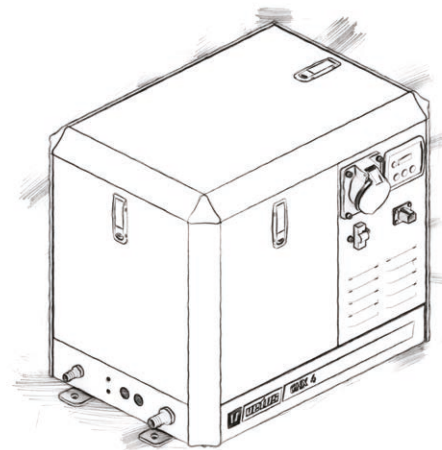

Standard scope of supply

All VETUS generators meet the EMC Low Voltage and machine requirements when mounted in a sound enclosure. They are supplied as standard with an exhaust system, a water intake system and a remote control panel.

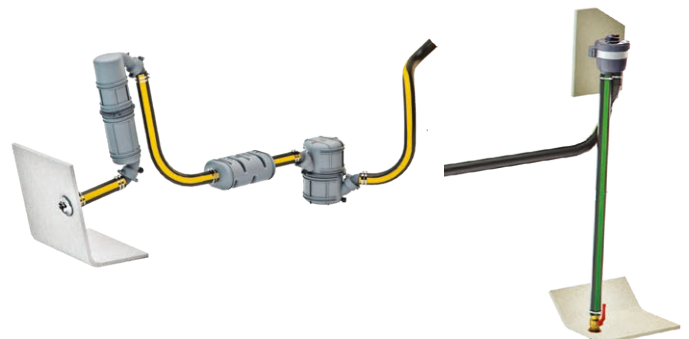

INVERTERS

Sine wave inverters and control panel, type IV

Type IV is a very compact and lightweight inverter which produces a pure sine wave using high frequency technology. All VETUS inverters have a shore power connection, a built-in UPS (uninterruptable power supply) function and LED bar for indication of the battery voltage and power consumption. Whenever the shore power is disconnected, the inverter will immediately switch over the power supply without affecting the connected equipment. The inverter is protected against overload, high or low battery voltage, high temperature and short-circuit.

Characteristics

- High peak power (a 3 kW inverter can produce 3.9 kW for up to 30 minutes)
- Universal AC outlet socket, compatible with all plugs worldwide
- UPS function
- 200 - 240 V 50/60 Hz selectable

Optional

By adding a remote control panel the inverter can be switched on and off from any convenient location. It can show the battery voltage and AC output status, the power output and the alarm functions.



IV



IVPANEL

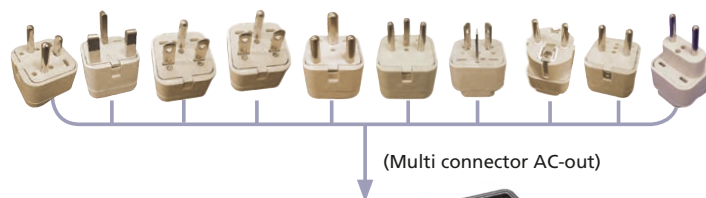

(Multi connector AC-out)



Type	IV60012	IV100012	IV150012	IV200012	IV300012	IV60024	IV100024	IV150024	IV200024	IV300024		
input	Nominal battery voltage		10 to 16 V				20 to 32 V					
	Max. input current at 10.5 resp. 21 Volt and Pnom.		67 A	112 A	167 A	223 A	334 A	34 A	56 A	84 A	112 A	167 A
output	Voltage										Adjustable: 200, 220, 230, or 240 V AC (+/-2%)	
	Frequency										Adjustable: 50 Hz or 60 Hz (+/- 0,05%)	
	Wave shape										Sinus, total harmonic distortion < 3%	
	Nominal power										Continuous at cos phi=1, at a maximum inverter temperature of 75°C	
			600 W	1000 W	1500 W	2000 W	3000 W	600 W	1000 W	1500 W	2000 W	3000 W
	Peak power*		60 min. 105-110%		30 min. 120-130%		10 min. 140-145%		5 sec. 150%		1 sec. 200%	
	Cos phi										All types of load are permitted	
Efficiency										83 - 85%		
Input voltage UPS mode					180 - 245 V AC, Switch time < 3msec.							
Ambient temperature					During storage: -22°F to +158°F / During use: 32°F to +122°F (inverter temp. 167°F)							
Relative humidity					Max. 95 %, condensation-free (all printed circuit boards are coated)							
Protection class											IP20	
Dimensions inches (mm)		13 ²⁵ / ₃₂ " x 11 ⁷ / ₃₂ " x 4 ²³ / ₃₂ "	15 ³ / ₄ " x 11 ⁷ / ₃₂ " x 4 ²³ / ₃₂ "	17 ²³ / ₃₂ " x 11 ⁷ / ₃₂ " x 4 ²³ / ₃₂ "	16 ¹ / ₂ " x 11 ⁷ / ₃₂ " x 7 ⁹ / ₃₂ "	19 ⁹ / ₆₄ " x 11 ⁷ / ₃₂ " x 7 ⁹ / ₃₂ "	13 ²⁵ / ₃₂ " x 11 ⁷ / ₃₂ " x 4 ²³ / ₃₂ "	15 ³ / ₄ " x 11 ⁷ / ₃₂ " x 4 ²³ / ₃₂ "	17 ²³ / ₃₂ " x 11 ⁷ / ₃₂ " x 4 ²³ / ₃₂ "	16 ¹ / ₂ " x 11 ⁷ / ₃₂ " x 7 ⁹ / ₃₂ "	19 ⁹ / ₆₄ " x 11 ⁷ / ₃₂ " x 7 ⁹ / ₃₂ "	
		350x285 x120	400x285 x120	450x285 x120	420x285 x185	490x285 x185	350x285 x120	400x285 x120	450x285 x120	420x285 x185	490x285 x185	
Weight lbs (kg)		12 (5.3)	14.5 (6.6)	16.5 (7.5)	24.2 (11)	29 (13)	12 (5.3)	14.5 (6.6)	16.5 (7.5)	24.2 (11)	29 (13)	

COMBI-GAMMA

Type COMBI-γ

Multi-function Inverter Charger

The VETUS COMBI can be used as an inverter and a battery charger. In combination with a VETUS solar charger, the Combi-γ unit can exchange data and control the current supply, as well as the charging characteristics.

This battery charger has a four-stage function: boost, absorption, float and equalize.

Extra features

- Power control: Selecting the maximum input current from the shore supply or 'genset', to ensure that the circuit breaker on the shore supply or generator will not trip
- Power Manager: The Power Manager function controls and regulates the entire power supply. If you need more power, the Power Manager will automatically switch in the inverter, in order to supply the required power. One 3 kW Combi-γ unit will therefore supply a total of 6kW (3kW via the inverter function and a further 3 kW from the shore supply or the generator)
- Uninterrupted Power Supply (UPS): This function will switch in automatically, when the shore power supply fails
- Parallel connection: Easily connecting up to 5 COMBI units in parallel via parallel box model CGP (to be ordered separately)
- 3-Phase functionality: Achieving a total output of 45kW by using 3kW COMBI'S (CG3PH)



COMBI

Remote control panel for Combi-γ

This panel displays the following information

- AC input and output voltage and current
- Battery voltage, current and power consumption
- Charging voltage and charging current levels of Combi-γ and solar charger
- UPS status
- Multifunctional relay status
- Alarms

It also controls

- Inverter, battery charger, solar charger ON/OFF
- Switching levels
- Charge voltage and current
- Relays
- Parallel 3-phase configuration
- AC output voltage and frequency

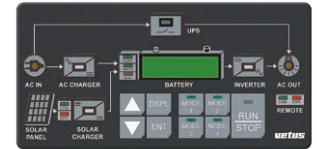

GAMPANEL

VETUS "Combi-γ", model		COMBI1512	COMBI3012	COMBI1524	COMBI3024
Inverter					
input	Nominal battery voltage	10-16 V			20-32 V
	Max. input current at 10.5V resp. 21V and Pnom	167 A	334 A	84 A	167 A
output	Voltage	Adjustable: 185-240 V AC			
	Frequency	Adjustable: 50 of 60 Hz ± 0.1%			
	Wave shape	Pure sine, total harmonic distortion < 3%			
	Nominal power	Continuous at cos phi =1, at a max. inverter temperature of 167°F			
	Peak power	1500 W	3000 W	1500 W	3000 W
	Cos phi (power factor)	60 min 105 - 110%	30 min 120 - 130%	10 min 140 - 135%	5sec. 150%
Battery charger					
input	Voltage	200-250 V AC			
	Frequency	45-55 Hz or 55-65 Hz			
	Cos phi (power factor)	1			
output	Charging Current	Adjustable			
	Maximum charging current	70 A	120 A	40 A	70 A
	Charging current starter battery	4 A			
General					
	Input power in UPS mode	180 -245, switch-over time < 3 msec.			
	Max. switching current UPS	16 A	30 A	16 A	30 A
	Max. current Power Control	10 A	20 A	10 A	20 A
	Multifunctional relay	3x			
	Ambient temperature	During storage: -22°F to +158°F. During use: 32°F to +122°F (inverter temp. 167°F)			
	Relative humidity	Max. 95%, condensation-free (all printed circuit boards are coated)			
	Protection class	IP20			

BATTERY CHARGERS

Type BC

Especially designed for marine use

These battery chargers have a four stage IUoU charge programme: In the first Bulk charge stage, the battery receives a continuous maximum current charge. Once the battery is recharged to approximately 75% of its full capacity, the charger switches automatically to a constant voltage Absorption stage for the remaining 25%.

When the battery is fully charged, the charger will maintain this charge phase for 15 minutes (providing the charge is under 6.25 % of the full charge current) and then switches over to the Float charge stage. In this stage the battery charger maintains the full charge without overloading the battery. It compensates for self-discharge and "floats" any loads on the battery.

After being in the float stage for 12 days, the charger implements the final Reconditioning stage. In this stage the charger will switch to the Bulk stage for 85 minutes only, to ensure that the battery stays in optimum condition. With easy access dipswitches, the maximum charge voltage can be adapted to suit the type of battery being charged. These chargers are suitable for all AC power sources from 90 V to 265 V. The active Power Factor Correction feature takes care of any unwanted line disturbances.

VETUS battery chargers are extensively tested, including a 2G vibration test, to meet our quality standards and ensure long term operation. These new chargers are compatible with Lead Acid, Li-ion, Gel, AGM and Deep Cycle batteries, and can be connected to a remote control panel (BCRC) and a battery temperature sensor (BCTS). The chargers have a separate alarm contact and the fan speed can be adjusted for comfort reasons.

A trickle charger with maximum output of 2A is provided on models BC12151, BC12252 and BC12352.

Specifications

- Universal AC input with active PFC (90 - 264 VAC)
- Compatible with Lead Acid, Li-ion, Gel and Deep Cycle batteries
- Remote control panel BCRC available as optional accessory
- Optional battery temperature sensor BCTS
- Voltage/temperature compensation
- High efficiency and high reliability
- Protection against short circuit/over voltage/over temperature



BC12...

BC24...

Type	Dimensions W x H x D inches (mm)	Standard Boost Charge Voltage (V)	Standard Float Charge Voltage (V)	Max Rated Current (A)	Single Output Current Limit (A)	Number of Outputs
BC12151	8 ¹ / ₁₆ x 3 ⁵ / ₁₆ x 10 ³ / ₁₆ (205 x 84 x 259)	14.4V / 14.7V	13.8 / 13.5	15	15	1 (1)
BC12252	8 ¹ / ₁₆ x 3 ⁵ / ₁₆ x 10 ³ / ₁₆ (205 x 84 x 259)	14.4V / 14.7V	13.8 / 13.5	25	25	2 (1)
BC12352	8 ¹ / ₁₆ x 3 ⁷ / ₁₆ x 11 (205 x 87 x 279)	14.4V / 14.7V	13.8 / 13.5	35	35	2 (1)
BC24122	8 ¹ / ₁₆ x 3 ⁵ / ₁₆ x 10 ³ / ₁₆ (205 x 84 x 259)	28.8V / 29.4V	27.6 / 27	12.5	12.5	2
BC12503	9 ⁵ / ₁₆ x 3 ⁹ / ₁₆ x 11 ⁵ / ₁₆ (237 x 90 x 288)	14.4V / 14.7V	13.8 / 13.5	50	40	3
BC24253	9 ⁵ / ₁₆ x 3 ⁹ / ₁₆ x 11 ⁵ / ₁₆ (237 x 90 x 288)	28.8V / 29.4V	27.6 / 27	25	25	3
BC12803	9 ⁵ / ₁₆ x 3 ⁹ / ₁₆ x 11 ⁵ / ₁₆ (237 x 90 x 288)	14.4V / 14.7V	13.8 / 13.5	80	40	3
BC24403	9 ⁵ / ₁₆ x 3 ⁹ / ₁₆ x 11 ⁵ / ₁₆ (237 x 90 x 288)	28.8V / 29.4V	27.6 / 27	40	40	3
BCRC	Remote control panel 2 ⁵ / ₆₄ x 2 ¹ / ₄ (72 x 57 mm), cut-out size Ø 1 ⁴⁷ / ₆₄ (44 mm)					
BCTS	Battery temperature sensor					



BCRC



BCTS



TRICKLE CHARGER / BATTERY MAINTAINER

Type BC12051

Intelligent charging in 5 stages

BC12051 controls the battery charging in 5 stages ensuring optimal performance from your batteries. It has an Ingress Protection Rating IP65, so it is dust, splash and rainproof.

- Stage 1** (desulfation): Recuperates a deeply discharged or lightly sulphated battery
- Stage 2** (boost charger): Charges the battery to 75% in the fastest and sufficient way
- Stage 3** (equalisation and analysis): Pulse charge at lower current to almost full charge
- Stage 4** (top-off): Fully charges the battery without overcharging
- Stage 5** (float): Maintains the battery in full-charge status

Specifications

- Dimensions L 6 19/64" x W 3 25/32" x H 2 1/8" (160 x 960 x 540 mm)
- Weight 1.9 lbs (0,85 kg)
- Charging voltage (max.) 14,8V / currents (max.) 5A
- Battery capacity up to 100Ah
- Ambient temperature -20° to +50°C
- AC Voltage input 220-240 VAC, 50/60Hz
- AC and DC cable length 6 ft. (1,83 m)



BC12051

Type	Description
BC12051	5-stage battery charger/maintainer

Battery splitter type BS

For optimal charging and maintenance

VETUS battery separators or splitters simultaneously charge 2 or 3 battery banks from any charging source with negligible voltage drop due to the use of mosfet transistors instead of diodes. One discharged battery cannot discharge another battery. This battery splitter ensures automatic distribution of the charging current from the alternator and/or battery charger. Once the engine has started, the alternator will automatically recharge all banks of batteries. The VETUS battery separators feature an auxiliary connection which provides feedback to voltage sensed alternators.

Specifications

- Suitable for 12 and 24 Volt installations, 2 or 3 battery banks and 1 or 2 alternators
- Maximum charging current 150A
- Input 8-30 Volt DC



BS1502C

BS1503C

BS15032C

Type	Number of inputs	Number of outputs	Maximum charging current (A)	Input voltage V (DC)	Weight lbs (kg)
BS1502C	1	2	150	8-30	2,2 (1,0)
BS1503C	1	3	150	8-30	2.65 (1,2)
BS15032C	2	3	150 (2x)	8-30	2.87 (1,3)

Battery boxes type BATBOX

For all VETUS batteries

VETUS battery boxes are made of polypropylene and come in 3 different sizes.

Type		Internal dimensions LxBxH inches (mm)
BATBOXS	Battery box - small	10 3/64" x 7 3/32" x 7 43/64" (255 x 180 x 195)
BATBOXM	Battery box - medium	13 25/32" x 7 3/32" x 7 43/64" (350 x 180 x 195)
BATBOXL	Battery box - large	9 27/32" x 13 25/32" x 6 1/2" (360 x 175 x 230)

Recommended battery box by battery

BATBOXS	VESMF60 - VEAGM60
BATBOXM	VESMF70 - VEAGM70
BATBOXL	VESMF85 - VESMF105 - VEAGM90 - VEAGM100



BATBOX

BATTERIES

VETUS batteries

Specially designed for use aboard pleasure craft

VETUS batteries are designed with consideration of the varying seasonal demands of boating. During the winter months the battery will mostly be unused, therefore the batteries have a minimal rate of self-discharge and can still be relied on to start the engine again the following season. We strongly advise the use of a float charger during winter storage. During the boating season, the batteries are able to supply both small constant loads as well as heavy but short loads for the use of a bow thruster. VETUS offers 3 different types of marine batteries, each with their own characteristics. To help you select the best battery for a specific purpose, please refer to the battery selection chart.

The SMF (Sealed Maintenance Free) series

Maintenance free, no need to be refilled!

- Sealed and maintenance free
- Lids which internally re-generate any gas that occurs during use or charging
- Construction based on use of lead-calcium plates which reduce water usage
- Models VESMF60, 70, 85 and 105 are equipped with a 'magic eye' which indicates the state of charge
- Manufactured in the EU



Specifications VETUS SMF batteries

Type	VESMF60	VESMF70	VESMF85	VESMF105	VESMF125	VESMF145	VESMF165	VESMF200	VESMF220
Voltage	12 V	12 V	12 V	12 V	12 V	12 V	12V	12V	12V
Capacity C20	60 Ah	70 Ah	85 Ah	105 Ah	125 Ah	145 Ah	165 Ah	200 Ah	220 Ah
Cold Cranking Amps CCA (EN)	540 A	640 A	680 A	710 A	950 A	1050 A	1250 A	1300 A	1400 A
Reserve capacity in minutes at 25A	93	110	165	190	230	301	322	431	445
Dimensions LxBxH inches	9 1/2" x 8" x 7"	11" x 8" x 8"	14" x 8" x 8"	13 1/2" x 8" x 9"	20 1/4" x 7 1/2" x 8 3/4"	20 1/4" x 8 3/4" x 8 3/4"	20 1/2" x 8 3/4" x 8 3/4"	20 1/2" x 11" x 9 1/2"	20 1/2" x 11" x 9 1/2"
Weight lbs (kg)	30.4 (13.8)	36 (16.2)	43.2 (19.6)	56.4 (25.6)	76 (34.4)	88 (39.9)	96.5 (43.8)	120 (54.5)	124 (56.2)
BATBOX	S	M	L	L	-	-	-	-	-

The AGM (Absorbed Glass Mat) series

Multipurpose marine batteries with long life spans

- Sealed VRLA (Valve Regulated Lead Acid) and maintenance free (does not contain any free electrolyte)
- Electrolyte is absorbed by glass fibre mat separators between battery plates
- Leakage-free even when the battery is dropped and the casing is damaged
- Battery can even be shipped by airfreight
- Manufactured in the EU



Specifications VETUS AGM marine batteries

Type	VEAGM60	VEAGM70	VEAGM90	VEAGM100	VEAGM140	VEAGM170	VEAGM185	VEAGM220
Voltage	12 V	12 V	12 V	12 V	12 V	12 V	12V	12V
Capacity C20	60 Ah	70 Ah	90 Ah	100 Ah	140 Ah	170 Ah	185 Ah	220 Ah
Capacity C5	43 Ah	50 Ah	67 Ah	75 Ah	115 Ah	135 Ah	155 Ah	185 Ah
Cold Cranking Amps CCA (EN)	530 A	680 A	800 A	760 A	1100 A	1300 A	1400 A	1500 A
Reserve capacity in minutes at 25A	103	125	175	210	267	336	383	496
Dimensions LxBxH inches	9 1/2" x 6 5/16" x 7 3/16"	10 15/16" x 6 5/16" x 7 3/16"	13 5/16" x 6 5/16" x 7 3/16"	13 1/2" x 6 5/16" x 9 1/16"	20 13/16" x 7 7/16" x 8 25/32"	20 13/16" x 8 25/32" x 8 25/32"	20 25/64" x 10 25/32" x 9 17/32"	20 25/64" x 10 25/32" x 9 17/32"
Weight lbs (kg)	36 (16.5)	42.5 (19.3)	55.5 (25.2)	64 (29.2)	92 (41.8)	108 (49)	126.5 (57.4)	132.2 (60)
BATBOX	S	M	L	L	-	-	-	-



BATTERIES

VETUS Deep Cycle battery

This type of deep cycle battery is ideal for applications such as electric propulsion. The VEDC110TC is a group 31 "Deep Cycle / Semi-traction" battery featuring two different connections. One set of conventional tapered battery clamp connections and one set of threaded connection (5/16") for cable lugs. Thicker plates inside the battery allow deeper discharging (up to 75%) compared to conventional batteries and can be used for cyclic applications. Because of this, the battery is very suitable for electric boating where the battery is discharged over a longer period of time. The VEDC110TC battery is based on a Sealed Maintenance Free battery, so the same battery chargers are applicable.



Specifications VEDC110TC

Type	
Voltage	12 V
Capacity C20	110 Ah
Capacity C5	90 Ah
Cold Cranking Amps CCA (EN)	800 A
Reserve capacity in minutes at 25A	200
Dimensions LxBxH	330x175x240
Weight (kg)	25,3
BATBOX	L

Specifications

- Suitable for heavy use over a longer period of time
- Two different connections
- Thicker battery plates
- Dischargeable up to 75%
- Compact
- Very suitable for electric propulsion or as a service battery
- Manufactured in the EU

Battery selection chart

Application	SMF Marine Battery	AGM Marine Battery	VEDC110TC Marine Battery
Engine starting	✓✓✓✓	✓✓✓	✓✓✓✓
Generator starting	✓✓✓✓	✓✓✓✓	✓✓✓✓
Bow thruster	✓✓✓	✓✓✓	✓✓✓✓
Anchor windlass	✓✓✓✓	✓✓✓✓	✓✓✓✓
Pumps	✓✓✓	✓✓✓	✓✓✓✓
Use with inverter	✓	✓✓✓	✓✓✓✓
Refrigeration	✓	✓✓✓	✓✓✓✓
Air conditioning	✓	✓✓✓	✓✓✓✓
Lighting	✓	✓✓✓	✓✓✓✓
Electric propulsion	✓	✓✓✓	✓✓✓✓

✓ - Not recommended ✓✓ - Suitable ✓✓✓ - Recommended ✓✓✓✓ - Highly recommended



Battery selection chart

	SMF Marine Battery	AGM Marine Battery	VEDC110TC Marine Battery
General			
Maintenance free	✓	✓	✓
Deep discharge	-	✓	✓✓
Typical life span	5-6 years	6-8 years	5-6 years
Number of cycles - %age discharge	350 - 35%	500 - 75%	+400 - 75%
Self discharge	< 3% per month	< 3% per month	< 3% per month
Electrolyte	Wet acid	Absorbed glass mat	Wet acid
Plate materials	Lead - calcium	Lead - calcium	Lead - calcium
VRLA (pressure relief vent)	-	✓	-
Series connection allowed	✓	✓	✓
Parallel connection allowed	✓	✓	✓
Safe transportation	-	✓	-
Maximum angle in use	55°	55°	55°
Maximum installation angle	0°	0°	0°
Charging with standard charger	✓	✓	✓

AUTOMATIC CHANGE-OVER DEVICE

Type IVPS

Constantly monitoring voltage range and power supply

If the power from the shore supply is disconnected or the generator output falls outside the 180-250 Volt range, this change-over device will automatically switch in the inverter. When both sources are available, the generator is given priority. When switching to the generator, a time lapse of 0 up to 30 seconds can be set.

Specifications

- Capacity 4.5 kVA
- Dimensions 11³/₈" x 7" x 3³/₄" (290 x 180 x 95 mm)
- Weight 5.2 lbs (2.4 kg)
- Nominal voltage 230 Volt AC, 50Hz

IVPS



Shore power protector type SPP

Protection against overload of shore supply

Shore power protector with LCD display and connection cable (2 mtr) provides a warning when the shore supply is overloaded. It will disconnect the overload before the breaker in the marina does. The shore power protector will not be affected by equipment with a high inrush current such as a refrigerator or air conditioning.

Specifications

- Input voltage 195 to 253 Volt AC / 50-60Hz
- Power consumption 5 Watt nominal
- Switch-off current 16A max. (user settable)
- Maximum switching power 3680 Watt resistive and weak inductive loads / 1500 Watt inductive loads at cos phi < 0,4
- Operation within the limits of B- or C-fuse characteristics, temperature 0-104°F (0-40°C)

SPP230



Solar charger type SL

Eco-friendly charging

The VETUS Solar Charger enables regulated battery charging when using solar panels. In addition to its charging function this unit ensures that, when the batteries are fully charged, the output of the solar panels can be used for other purposes (diversion regulation). In order to prevent complete discharge of the battery, the charging control function will disconnect any consumers when the battery voltage drops too low. The VETUS Solar Charger may be used as a stand alone unit, or in combination with the VETUS Combi-γ unit. In this case the Combi-γ will control the complete current supply. To allow the solar charger to communicate with the Vetus Combi, please use the special 10 core connection cable RJ4510xx. Up to 10 Solar Chargers may be connected in parallel formation.

The Solar Charger is protected against

- Short circuit
- Current overload from solar panel
- Reversed battery polarity
- Excess temperature

Solar Charger, type	SL45	SL60
Maximum charging current	45 A	60 A
Charging characteristics	4-stage	
Battery voltage	12-48 V	
Maximum voltage of solar panel	125 V	
Minimum voltage of solar panel	9 V	
Ambient temperature	During storage: -67°F to +185°F - During use: -40°F to +113°F	
Relative humidity	Max. 95%, condensation-free (p.c.b. is coated)	
Dimensions (H x W x D) in inches (mm)	10 ¹ / ₂ x 5 x 3 (266 x 127 x 75)	
Weight lbs (kg)	3.3 (1.5)	



SL



ACCESSORIES

Battery selector switch type ACCUSCH

Famous for its multifunctional use

From the OFF position, in accordance with the switch pattern, battery 1 only, battery 1 plus battery 2 or battery 2 only can be switched on. The switch enables usage and charging of the batteries individually and in parallel connection. The switch has a red locking button which indicates and locks the switch position, discouraging enthusiastic operation. Even though the battery selector is fitted, you still have the choice which battery will supply which service. If your chosen battery is nearly discharged or defective, the other battery can be called to the rescue. By using a VETUS battery selector switch, the starter and domestic battery can be used and charged as you desire. The switch will "make before break" and so battery selection is possible even with the engine running (do not go through the "Off" position).



Specifications

- Capacity at 6, 12, 24 or 32 Volt
- Continuous 175A / interval 300A
- Dimensions 5⁵/₁₆" x 5⁵/₁₆" x 2⁶/₆₄" (135x135x75 mm).

Type	Description
ACCUSCH	Battery selector switch

ACCUSCH

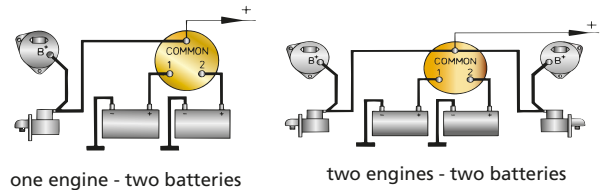

Battery main switches type BATSW

Twin pole switching

May be connected to either the positive or the negative electric cable. Two positions: "ON" and "OFF". In the "OFF" position the key may be removed (except models 150 and 600). Provided with two M10 connectors. Model 250T is a twin pole switch to make/break both the positive and negative cables. Model 600 is watertight according to IP 67.

BATSW075



BATSW100



BATSW150



BATSW250



BATSW250T



BATSW600



Type	BATSW075	BATSW100	BATSW150R* BATSW150B**	BATSW250	BATSW250T	BATSW600
Nominal operational (V)	max. 24	max. 24	max. 24	max. 24	max. 48	max. 24
Current max.:						
- Continuous operation	75 A	100 A	150 A	250 A	2 x 250 A	450 A
- 3 minutes' load						800 A
- 5 seconds' load	350 A	500 A	1000 A	2500 A	2 x 2500 A	3500 A

* BATSW150R = with red handle

**BATSW150B = with black handle

ACCESSORIES

Fuses and fuse holder type ZE

Type ZEHC is suitable for VETUS fuses of 40 - 500 Amp. The fuses to match are encapsulated in glass to prevent splatter and fire. The fuse holder comes with a protector cover.

Note

Can be used in combination with strip fuses type ZE.



ZEHC100



ZE

Type	Description
ZEHC100	Fuse holder, type C100 including cover

Type	Description	Amp.
ZE040	Strip fuse C20	40
ZE050	Strip fuse C20	50
ZE063	Strip fuse C20	63
ZE080	Strip fuse C20	80
ZE100	Strip fuse C20	100
ZE125	Strip fuse C20	125
ZE160	Strip fuse C20	160

Type	Description	Amp.
ZE200	Strip fuse C20	200
ZE250	Strip fuse C20	250
ZE300	Strip fuse C20	300
ZE355	Strip fuse C20	355
ZE425	Strip fuse C20	425
ZE500	Strip fuse C20	500

Make/break relay - solenoid type AFSTD and SOL

Make/break relay to reverse the direction of rotation of an electric motor (e.g. windlass) with a maximum output of 1.5 kW at 12 Volt, 3 kW at 24 Volt and 6 kW at 24 Volt (type AFST624D).

* Type SOL is watertight to IP66.

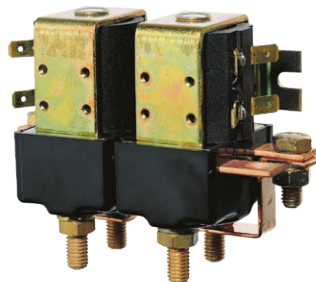

AFST1512D

SOL1512D*

SOL324D*

AFST324D

AFST624D

Type	Description	Volt / Watt	Terminals
AFST1512D	Dual make/break relay	12 / 1500	M8
SOL1512D	Dual make/break relay	12 / 1500	M6
SOL324D	Dual make/break relay	24 / 3000	M6
AFST324D	Dual make/break relay	24 / 3000	M8
AFST624D	Dual make/break relay	24 / 6000	M10

Single relay - solenoid type AFSTS and SOL

When the motor has 2 field windings, 2 of these relays can be used to operate the motor in either direction.

* Type SOL is watertight to IP66.



AFST1512S

SOL1512S*

SOL324S*

AFST324S

AFST624S

Type	Description	Volt / Watt	Terminals
AFST1512S	Single relay	12 / 1500	M8
SOL1512S	Single relay	12 / 1500	M6
SOL324S	Single relay	24 / 3000	M6
AFST324S	Single relay	24 / 3000	M8
AFST624S	Single relay	24 / 6000	M10



ACCESSORIES

Battery cables type BATC

These extremely flexible cables have a PVC insulation jacket with a temperature range of 4° to + 185°F (-20° to +85°C). The cables are available in black for negative and red for positive direct current with a cross sectional area of 6, 10, 35, 50, 70, 95, 120 or 150 mm².

Note

The matching battery cable tags should be ordered separately (type BATCC).



BATC

Type	Cross sectional area (mm ²)	Colour
BATC06M	6	Black
BATC10M	10	Black
BATC35	35	Black
BATC50	50	Black
BATC70	70	Black
BATC95	95	Black
BATC120	120	Black
BATC150	150	Black

Type	Cross sectional area (mm ²)	Colour
BATC06RM	6	Red
BATC10RM	10	Red
BATC35R	35	Red
BATC50R	50	Red
BATC70R	70	Red
BATC95R	95	Red
BATC120R	120	Red

Cable lugs for battery cables type BATCC



BATCC

Type	For cable cross sections (mm ²)	Hole	Pack of
BATCC0606	6	M6	10
BATCC0608	6	M8	10
BATCC0610	6	M10	10
BATCC1006	10	M6	10
BATCC1008	10	M8	10
BATCC1010	10	M10	10
BATCC3506	35	M6	2
BATCC3508	35	M8	2
BATCC3510	35	M10	2
BATCC5006	50	M6	2
BATCC5008	50	M8	2

Type	For cable cross sections (mm ²)	Hole	Pack of
BATCC5010	50	M10	2
BATCC7006	70	M6	2
BATCC7008	70	M8	2
BATCC7010	70	M10	2
BATCC9508	95	M8	2
BATCC9510	95	M10	2
BATCC9512	95	M12	2
BATCC1210	120	M10	2
BATCC1212	120	M12	2
BATCC1510	150	M10	2
BATCC1512	150	M12	2

Battery terminal sets type BATT

Suitable for cables with cross sections of 1/32 (16 mm²) - 3/64 in² (35 mm²) 1/64 in² (50 mm²) - 9/64 in² (95 mm²) and up to 15/64 in² (150 mm²). Supplied with a M10 bolt for a cable up to 15/64 in² (150 mm²). Made of tinned brass with a stainless steel nut and bolt.

Type	Description
BATT1635	Terminal set for cable 1/32 - 3/64 in ² (16 - 35 mm ²), pack of 2
BATT5095	Terminal set for cable 5/64 - 9/64 in ² (50 - 95 mm ²), pack of 2
BATT150	Terminal with M10 bolt, for cable up to 15/64 in ² (150 mm ²), pack of 2



BATT

STEERING SYSTEMS

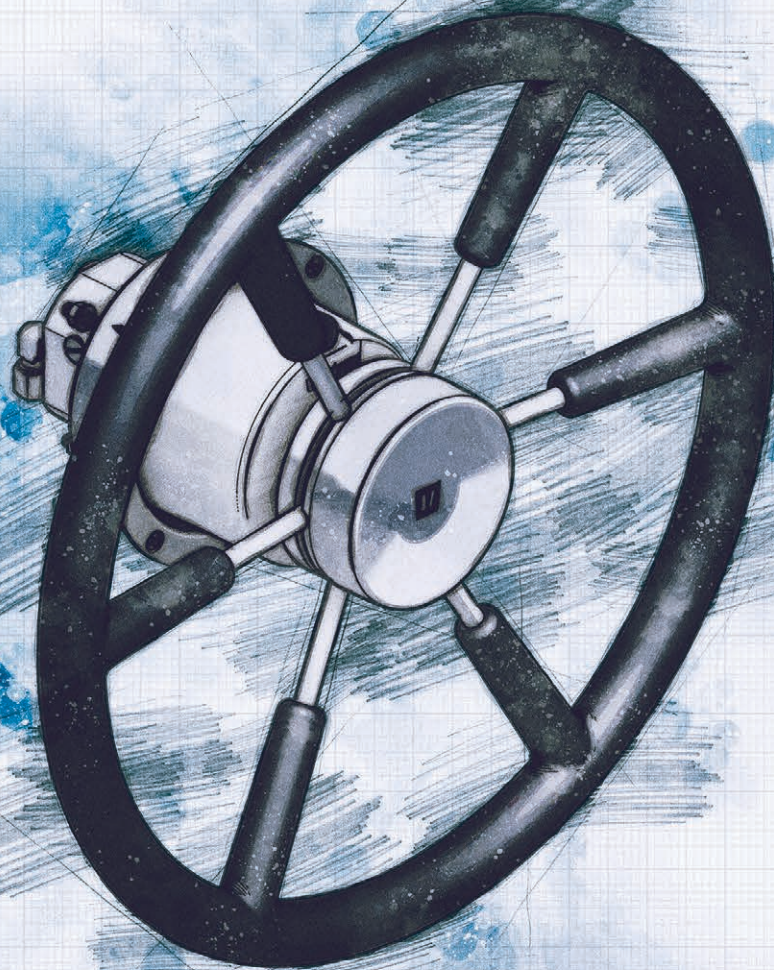

Overview VETUS steering systems

Steering wheels see page 239



Steering pumps see page 245

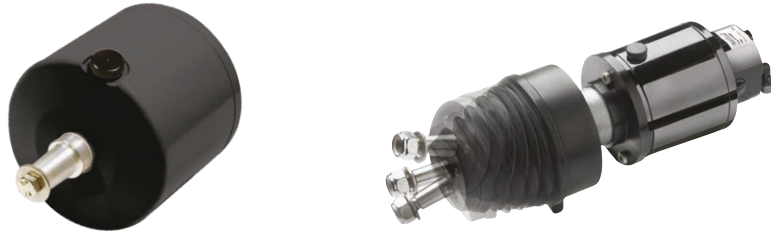

Steering cylinders see page 246



Accessories see page 253

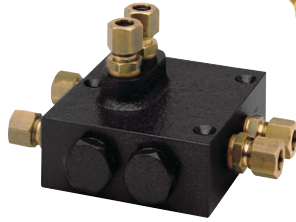
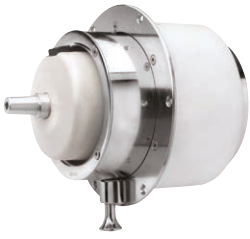

Rudders see page 256



Remote control steering see page 258



HOW TO DETERMINE THE CORRECT VETUS STEERING

Various combinations of boat speed, rudder blade surface area and balance sections apply a variety of forces on steering systems. Furthermore the dynamic influences of wind and currents cause steering systems to be continuously used under sometimes harsh conditions.

A skipper is dependent on the steering system and therefore it must be reliable under all circumstances. The design of the steering system determines how rapidly the vessel responds to helm movements. Fast light vessels react quickly to small rudder movements, while a slow, heavy displacement vessel will usually be set up to require more wheel movement for a given change of course. A thoughtful calculation of a steering system is therefore essential.

This chapter explains how the appropriate steering system can be determined for any boat.

Make your choice from a wide range of steering wheels and steering systems in this chapter.

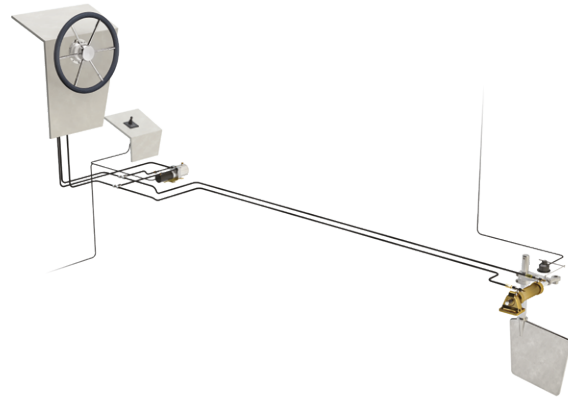

RUDDER TORQUE

The choice of the correct cylinder is determined by the rudder torque in Nm (or kg). The rudder torque is the determining factor (Torque = force x lever). To ascertain the correct rudder torque, only the maximum speed of the vessel, the surface area of the rudder blade and the maximum rudder angle (in degrees) are of importance. Information such as length of boat and engine power are irrelevant. With a few exceptions, the rudder performs best with a maximum rudder angle of 35° to either side. Contrary to what is sometimes claimed for rudders with normal dimensions, a larger rudder angle does not enhance the manoeuvring capabilities of a vessel.

Your VETUS customer support representative will be pleased to provide you with recommendations for all steering system components, based on the maximum speed of the vessel and a dimensioned sketch or the rudder (provided by you).

The formula to determine the rudder torque:

M (torque) = F x b (per rudder)

In other words: the force F, which is applied to the rudder (given in Newton = N), is being multiplied by the lever "b", being the distance between the centerline of the rudder stock and the centre of pressure which lies on the line X-Y.

F (the force applied to the central line XY) – taking into consideration a maximum rudder angle of 2 x 35° – is constituted in the following manner:

F = 23.3 x A x v² in Newton (N), or: F = 2.33 x A x v² in kgf.

A = total surface area of rudder blade in m².

v = speed in km/hour.

A rudder **without** balance section requires the formula:

b = 0.37 (1.21 ft.) x c (in metres);

A rudder **with** balance section calls for the formula:

b = (0.37 (1.21 ft.) x c) - e (in metres).

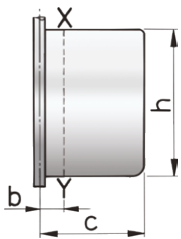

Rudder without balance section

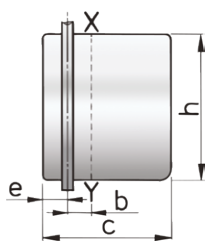

Rudder with balance section

Calculation example of one rudder with balance section

The maximum speed of the boat is 16 km/hour (v); the total width of the rudder blade is 57 cm (c); the width of the balance section is 9 cm (e); the height of the rudder blade is 100 cm (h).

F = 23.3 (1.67 lbf) x 0.57 (1.9 lbf) x 1.00 (3.3 lbf) x 16² (92 lbf) = 3400 N (340 kgf)

b = (0.37 (1.21 ft.) x 0.57 (1.87 ft.)) - 0.09 (0.3 ft.) = 0.12 (0.39 ft.) m.

Therefore, the rudder torque amounts to 3400 x 0.12 = 408 Nm (41 kgm) (848 x 0.403 = 342 ft.lbs.). So, the VETUS hydraulic steering to be selected in this case is model MTC52. With a twin rudder installation, the required torque is 2 x 408 Nm = 816 Nm, which makes model MTC125 the one to choose. We recommend that you consult VETUS for an accurate calculation. We also calculate the effects of the propeller wash, as well as the torque when going astern. Because smaller vessels tend to respond quite sharply to the rudder commands, the maximum rudder torque is not used and a reduction of 10 to 20% off the calculated maximum torque is quite acceptable most of the time. Be careful: some manufacturers of hydraulic steering systems have already taken such reduction into account when stating their capacity (torque). We, at VETUS, are of the opinion however, that the choice of whether or not such reduction should be applied, is exclusively the option of the naval architect.

All VETUS steering systems meet the CE ISO 8848 standard

STEERING WHEELS

Type PRO

The perfect match for traditional and modern boats

Type PRO has 2 models. Type 'T' with a satin-gloss varnished teak rim and type 'P' with a semi-hard polyurethane rim which will keep your hands warm. Both models have substantial spokes and a hub cover made of high-gloss polished stainless steel (AISI 316). The hub itself is made of synthetic material and bored for a $\text{Ø} \frac{3}{4}$ " shaft with 1:12 taper which will fit most steering systems. These steering wheels are according to the CE and ABYC directives.

Specifications

- Available with overall diameters of 16", 20" or 24" (600 mm), (400, 500 or 600 mm)
- Outer rim $\text{Ø} 1 \frac{1}{4}$ " (32 mm)

Note: An alternative hub to suit older VETUS steering pumps with a $\text{Ø} 1$ " hole shaft and $3 \frac{1}{2}:12$ taper is also available (product code: SETPS1).



PRO..P



PRO..T

Type	Description	Ø inches (mm)	Ø Outer rim inches (mm)
PRO40P	Polyurethane rim steering wheel	16 (400)	1 ¼ (32)
PRO50P	Polyurethane rim steering wheel	20 (500)	1 ¼ (32)
PRO60P	Polyurethane rim steering wheel	24 (600)	1 ¼ (32)
PRO40T	Teak steering wheel	16 (400)	1 ¼ (32)
PRO50T	Teak steering wheel	20 (500)	1 ¼ (32)
PRO60T	Teak steering wheel	24 (600)	1 ¼ (32)

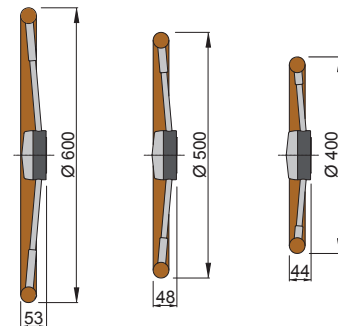

PASBUS A

All VETUS wheels and steering pumps have a $\text{Ø} \frac{3}{4}$ " bore, with a 1:12 taper. The PASBUS is a tapered bushing that can be applied to the $\frac{3}{4}$ " shaft of a steering pump so that it can receive a wheel with a 1" bore. This allows wheels made by others to be installed on our pumps.



PASBUS A



STEERING WHEELS

Mahogany steering wheels - Type KW / KWL

This mahogany steering wheel range now has five models from 14^{15/16}" (380 mm) to 31^{7/8}" (810 mm) diameter.

The spokes and hubcap are made from stainless steel (AISI 316). The hub itself is made from seawater resistant aluminium. The beautiful rim is constructed from high gloss lacquered mahogany. Type KWL also features lacquered mahogany spoke sleeves.

Characteristics

- KW series now available in the following diameters: 14^{15/16}", 17^{11/16}", 21^{5/8}", 27^{15/16}" and 31^{7/8}" (380, 450, 550, 710 and 810 mm)
- High-quality mahogany rim paired to stainless steel (AISI 316) spokes and hubcap
- Aluminium hub bored 19 mm (3/4") with 1:12 taper as standard

Note

An alternative hub to suit older VETUS steering pumps with a Ø 1" hole shaft and 3½:12 taper is also available (product code: SETKS1).

Type	Description	Ø inches (mm)	Ø shaft inches (mm)	Tapered
KW38	Steering wheel with mahogany rim	14 ^{15/16} (380)	¾ (19)	1:12
KW45	Steering wheel with mahogany rim	17 ^{11/16} (450)	¾ (19)	1:12
KW55	Steering wheel with mahogany rim	21 ^{5/8} (550)	¾ (19)	1:12
KW71	Steering wheel with mahogany rim	27 ^{15/16} (710)	¾ (19)	1:12
KW81	Steering wheel with mahogany rim	31 ^{7/8} (810)	¾ (19)	1:12

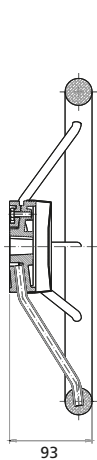
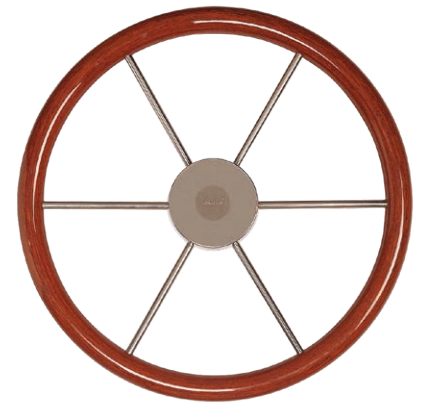

KW38



KW45

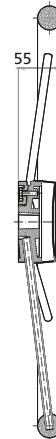

KW55

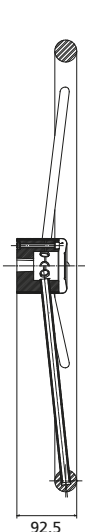

KW71

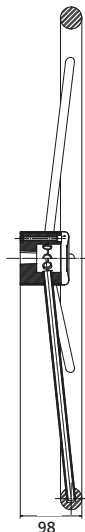

KW81



STEERING WHEELS

Type KWL

With a mahogany rim

Type	Description	Ø inches (mm)	Ø shaft inches (mm)	Tapered
KWL38	Steering wheel with mahogany rim and spokes	14 ¹⁵ / ₁₆ (380)	¾ (19)	1:12
KWL45	Steering wheel with mahogany rim and spokes	17 ¹¹ / ₁₆ (450)	¾ (19)	1:12
KWL55	Steering wheel with mahogany rim and spokes	21 ⁵ / ₈ " (550)	¾ (19)	1:12

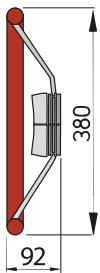

KWL38

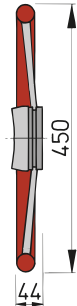

KWL45

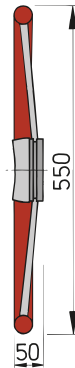

KWL55

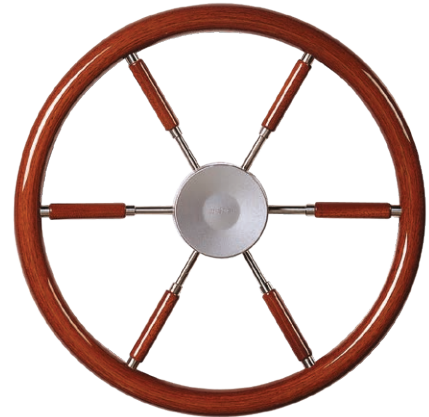

Type KS

No more cold hands

Model KS has stainless steel (AISI 316) rims, spokes and cap. The rims have a layer of semi-hard PU-foam with an integral skin. These soft-feel wheels are resistant to all weather conditions.

Specifications

- Available with overall diameters of 12⁵/₈"", 14³/₁₆"", 14¹⁵/₁₆" and 21⁵/₈" (320, 360, 380, 450 and 550 mm)
- All type KS wheels are supplied in the colours grey (RAL 704) or black
- Bored for Ø ¾" shaft, tapered 1:12

Note

An alternative hub to suit older VETUS steering pumps with a Ø 1" hole shaft and 3½:12 taper is also available (product code: SETKS1).

Type	PU-foam layer	Ø inches (mm)	Ø shaft inches (mm)	Tapered
KS32G	Grey	2 ⁵ / ₈ (320)	¾ (19)	1:12
KS32Z	Black	2 ⁵ / ₈ (320)	¾ (19)	1:12
KS36G	Grey	14 ³ / ₁₆ (360)	¾ (19)	1:12
KS36Z	Black	14 ³ / ₁₆ (360)	¾ (19)	1:12

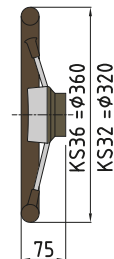

KS32G

KS32Z



KS36G

KS36Z



STEERING WHEELS

Type KS

Type	PU-foam layer	Ø inches (mm)	Ø shaft inches (mm)	Tapered
KS38G	Grey	14 ¹⁵ / ₁₆ (380)	¾ (19)	1:12
KS38Z	Black	14 ¹⁵ / ₁₆ (380)	¾ (19)	1:12
KS45G	Grey	17 ¹¹ / ₁₆ (450)	¾ (19)	1:12
KS45Z	Black	17 ¹¹ / ₁₆ (450)	¾ (19)	1:12
KS55G	Grey	21 ⁵ / ₈ (550)	¾ (19)	1:12
KS55Z	Black	21 ⁵ / ₈ (550)	¾ (19)	1:12

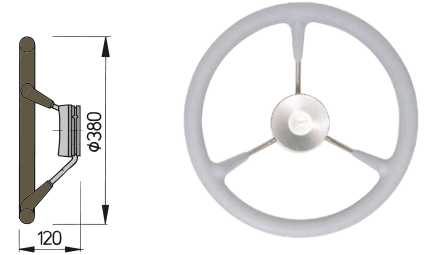

KS38G

KS38Z

KS45G

KS45Z

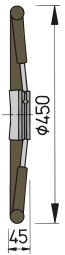

KS55G

KS55Z

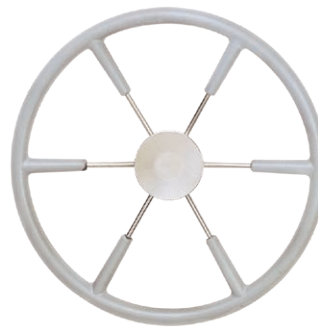
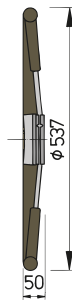

Type SWSPORT

Sport steering wheel

A sporty three-spoke steering wheel finished in carbon with a diameter of 350 mm. Bored for Ø ¾" shaft, tapered 1:12.

Type	Ø inches (mm)
SWSPORT Three spoke sport steering wheel, carbon finish	13¾ (350)

SWSPORT



Type SWCRUISER

Cruiser steering wheel

A three-spoke steering wheel finished in silver aluminium accents and a diameter of 350 mm. Bored for Ø ¾" shaft, tapered 1:12.

Type	Ø inches (mm)
SWCRUISER Three spoke sport steering wheel, black with aluminium inserts	13¾ (350)

SWCRUISER



STEERING WHEELS

SW Series

Made from high-quality polyurethane rubber, leather, wood and polished aluminium, these six steering wheels each emit their own vibe. From the classic wooden Tectona, to the futuristic Argentus and the minimalistic Ravus: all styles are present. Dimensions are kept small to maximize feel and enforce the sporty image, ranging from 11¹³/₁₆" to 13³/₄" (300 to 350 mm). All steering wheels feature a classy chromed ABS centre cap with the distinctive 'V' logo. Upgrade your interior with one of those stylish steering wheels.

The purpose-built and sporty appearance of the steering wheels complements your boat and with the materials used, they are built to last.

Specifications

- SW series now available in the following diameters: 11¹³/₁₆", 12⁵/₈", 13 and 13³/₄" (300, 320, 330 and 350 mm)
- Six new models in different colors to suit all vessels
- High-quality polyurethane rim paired to polished aluminium spokes and hubcap
- High-quality wooden rim paired to polished aluminium spokes and hubcap
- Bored for Ø 3/4" shaft, tapered 1:12.



ALBUS

Type	Description	Diameter inches (mm)	Colour / Material
SWALB30	Steering wheel "Albus"	11 ¹³ / ₁₆ (300)	White leather
SWTEC35	Steering wheel "Tectona"	13 ³ / ₄ (350)	Wood
SWALT33	Steering wheel "Alter"	13 (330)	Black polyurethane rubber
SWRAV33	Steering wheel "Ravus"	13 (330)	Gray polyurethane rubber
SWARG32	Steering wheel "Argentus"	12 ⁵ / ₈ (320)	Black p.u. rubber w/ chrome inserts
SWNOC35	Steering wheel "Noctis"	13 ³ / ₄ (350)	Black p.u. rubber w/ chrome inserts



TECTONA



ALTER



RAVUS



ARGENTUS



NOCTIS



STEERING SYSTEM CONFIGURATIONS

Below you will find examples of steering systems with one or two steering positions and one or two rudders, with or without non return valves.

Single steering position base system components

1 Steering pump with or without built-in non-return valves

- 1 Cylinder
- 1 Steering pump
- Hydraulic tubing (with end fittings) and fluid
- Optional: Separate dual non-return valve or by-pass valve (see below)



Dual steering positions base system components

- Two steering pumps with built-in non-return valves
- Alternatively: two steering pumps without non-return valves, in which case a separate dual non-return valve block must be fitted
- 1 Cylinder
- 2 T- pieces
- Hydraulic tubing (with end fittings) and fluid
- Optional: By-pass valves (see below)

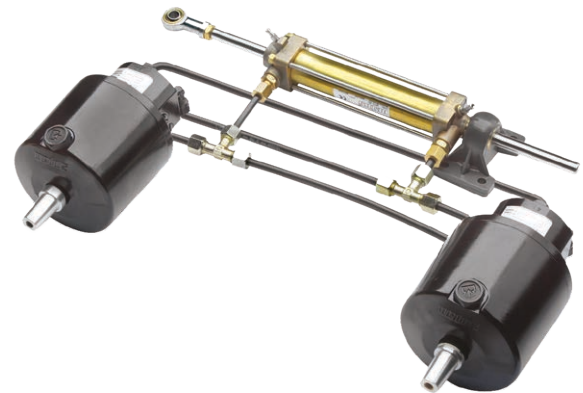

Dual rudder steering

Specifically suitable for catamarans!

Dual rudders which are not connected by a tie-bar can be operated by 2 cylinders and 1 pump with or without built-in non-return valves.

Specifications

- 2 Cylinders
- 1 Steering pump
- Hydraulic tubing (with end fittings) and fluid
- 2 By-pass valves
- Optional: Separate dual non-return valve

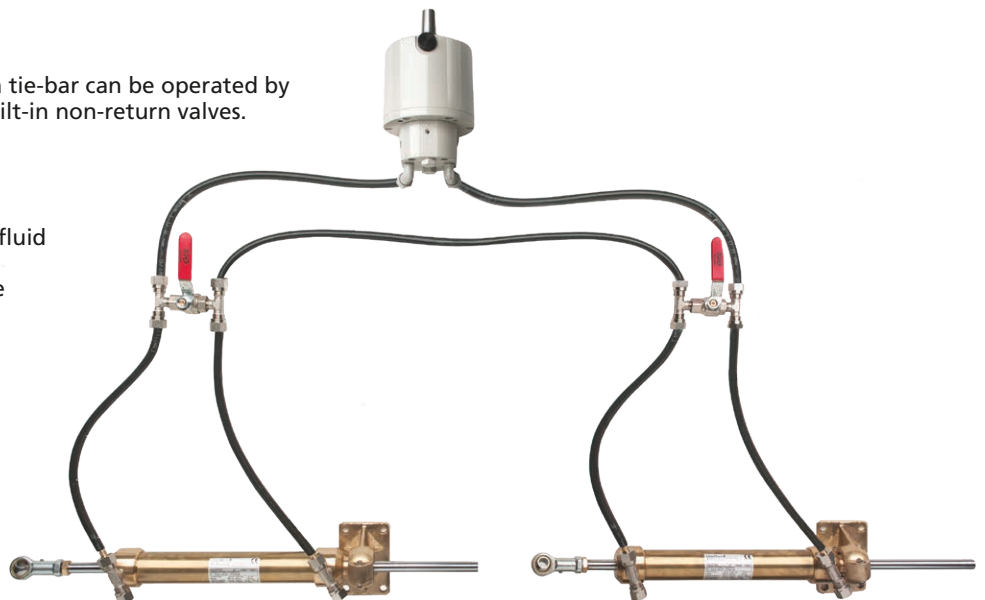

STEERING PUMPS

HTP and HTPR

These hydraulic steering pumps are suitable for almost all steering wheels, including VETUS wheels (see pages 239 - 243) and have a $\varnothing 3/4"$ shaft, tapered 1:12. Available in black or white.

Both types are supplied with

- Compression fittings (for the pressure lines) and a balance pipeline port
- Mounting studs, nuts and washers
- One vented and one un-vented filler plug

Type HTPR has in addition

- An integral non-return valve with continuous air bleeding system
- An integral pressure relief valve for protection against over pressurisation of the system



HTP.B

HTP

VETUS offers 2 different types of steering pumps

Types HTP 20/30/42

A steering pump without non-return valves.



HTP20

HTP30

HTP42

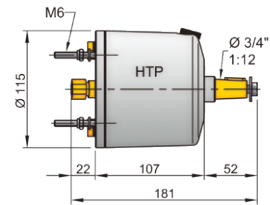

HTP

Steering pumps without non return valves

Type	Color	Ø inches (mm) tubing	Capacity in ³ (cm ³)/rev.	Number of pistons	Weight without valve lbs (kg)
HTP2010	White	3/8 (10)	1,2 (19,7)	5	7,2 (3,3)
HTP3010	White	3/8 (10)	1,8 (30,0)	5	7,2 (3,3)
HTP4210	White	3/8 (10)	2,5 (42,0)	7	7,2 (3,3)
HTP2010B	Black	3/8 (10)	1,2 (19,7)	5	7,2 (3,3)
HTP3010B	Black	3/8 (10)	1,8 (30,0)	5	7,2 (3,3)
HTP4210B	Black	3/8 (10)	2,5 (42,0)	7	7,2 (3,3)

Type HTPR 20/30/42

A steering pump with integral non-return valve and pressure relief valves.



HTP20R

HTP30R

HTP42R

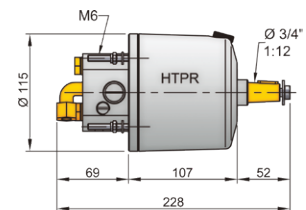

HTPR

Steering pumps with non return valves

Type	Color	Ø inches (mm) tubing	Capacity in ³ (cm ³)/rev.	Number of pistons	Weight without valve lbs (kg)
HTP2010R	White	3/8 (10)	1,2 (19,7)	5	90,3 (4,1)
HTP3010R	White	3/8 (10)	1,8 (30,0)	5	90,3 (4,1)
HTP4210R	White	3/8 (10)	2,5 (42,0)	7	90,3 (4,1)
HTP2010RB	Black	3/8 (10)	1,2 (19,7)	5	90,3 (4,1)
HTP3010RB	Black	3/8 (10)	1,8 (30,0)	5	90,3 (4,1)
HTP4210RB	Black	3/8 (10)	2,5 (42,0)	7	90,3 (4,1)

CYLINDERS

The cylinders below are supplied as standard with zinc plated steel rod ends. Stainless steel (AISI 316) rod ends are available as an option. For accessories see page 253.

Type	Ø inches (mm) tubing
MTC5210	3/8 (10)
MTC7210	3/8 (10)



MTC5210



MTC7210

MTC5210

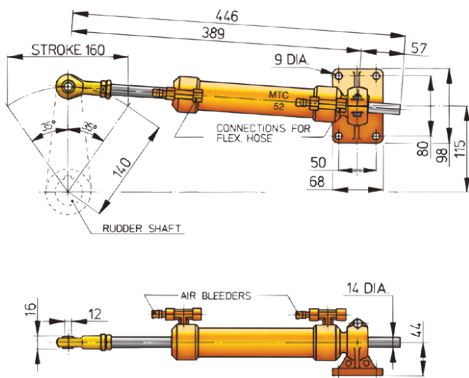

MTC7210

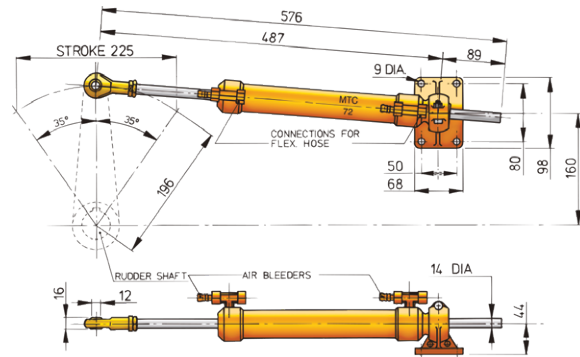

The cylinders below are supplied as standard with zinc plated steel rod ends. Stainless steel (AISI 316) rod ends are available as an option. For accessories see page 253.

Type	Ø inches (mm) tubing
MTC12510	3/8 (10)
MTC17510	3/8 (10)



MTC12510



MTC17510

MTC12510

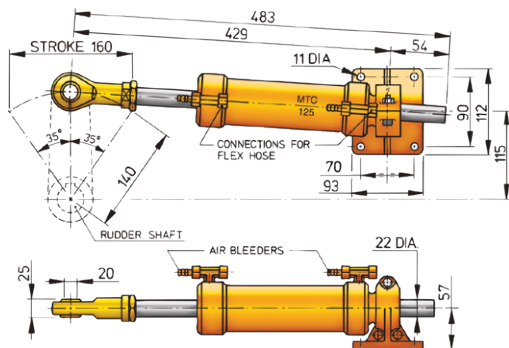

MTC17510

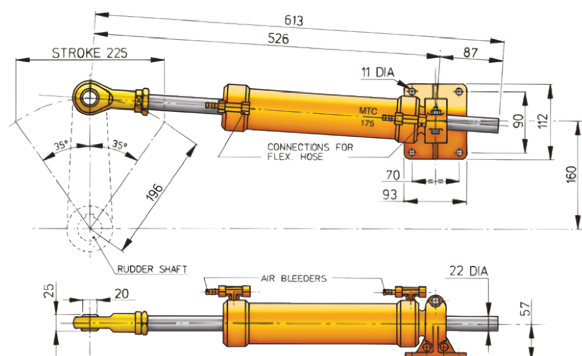

STEERING PUMPS AND CYLINDERS

This table shows combination of pumps and cylinders.



Cylinder type MTC5210

- Stroke 6⁵/₁₆" (160 mm)
- Volume 6.3 cu.inch (104 cm³)
- Length of tiller arm 5¹/₂" (140 mm)
- Weight 7.4 lbs (3.4 kg)



Pump type 20

Wheel turns 5.3

- Max. Torque **510Nm (52kgm)** (376ft.lbs).
- Torque at 35° and 56kg/cm²: 412Nm (42kgm) (304ft.lbs)
- Tubing: nylon hose Ø 1/4" (6 mm) x Ø 3/8" (10 mm) copper Ø 5/16" (8 mm) x Ø 3/8" (10 mm)

Pump type 30

Wheel turns 3.5

- Max. Torque **510Nm (52kgm)** (376ft.lbs).
- Torque at 35° and 56kg/cm²: 412Nm (42kgm) (304ft.lbs)
- Tubing: nylon hose Ø 1/4" (6 mm) x Ø 3/8" (10 mm) or Ø 5/16" (8 mm) x Ø 1/2" (12 mm) copper Ø 5/16" (8 mm) x Ø 3/8" (10 mm)

Pump type 42

N/A

Cylinder type MTC7210

- Stroke 8⁷/₈" (225 mm)
- Volume 8.9 cu.inch (146 cm³)
- Length of tiller arm 7³/₄" (196 mm)
- Weight 8.4 lbs (3.8 kg)



Wheel turns 7.5

- Max. Torque: **706Nm (72kgm)** (521ft.lbs).
- Torque at 35° and 56kg/cm²: 589Nm (60kgm) (434ft.lbs)
- Tubing: nylon hose Ø 1/4" (6 mm) x Ø 3/8" (10 mm) copper Ø 5/16" (8 mm) x Ø 3/8" (10 mm)

Wheel turns 4.9

- Max. Torque **706Nm (72kgm)** (376ft.lbs).
- Torque at 35° and 56kg/cm²: 589Nm (60kgm) (434ft.lbs)
- Tubing: nylon hose Ø 1/4" (6 mm) x Ø 3/8" (10 mm) or Ø 5/16" (8 mm) x Ø 1/2" (12 mm) copper Ø 5/16" (8 mm) x Ø 3/8" (10 mm)

Wheel turns 3.5

- Max. Torque **706Nm (72kgm)** (376ft.lbs).
- Torque at 35° and 56kg/cm²: 589Nm (60kgm) (434ft.lbs)
- Tubing: nylon hose Ø 1/4" (6 mm) x Ø 3/8" (10 mm) or Ø 5/16" (8 mm) x Ø 1/2" (12 mm) copper Ø 5/16" (8 mm) x Ø 3/8" (10 mm)

Cylinder type MTC12510

- Stroke 6⁵/₁₆" (160 mm)
- Volume 15.5 cu.inch (253 cm³)
- Length of tiller arm 5¹/₂" (140 mm)
- Weight 15.7 lbs (7.1 kg)

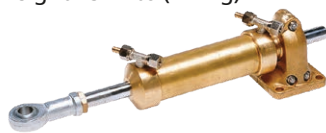

N/A

Wheel turns 8.5

- Max. Torque **1226Nm (125kgm)** (904ft.lbs).
- Torque at 35° and 56kg/cm²: 981Nm (100kgm) (723ft.lbs)
- Tubing: nylon hose Ø 1/4" (6 mm) x Ø 3/8" (10 mm) or Ø 5/16" (8 mm) x Ø 1/2" (12 mm) copper Ø 5/16" (8 mm) x Ø 3/8" (10 mm)

Wheel turns 6.1

- Max. Torque **1226Nm (125kgm)** (904ft.lbs).
- Torque at 35° and 56kg/cm²: 981Nm (100kgm) (723ft.lbs)
- Tubing: nylon hose Ø 1/4" (6 mm) x Ø 3/8" (10 mm) or Ø 5/16" (8 mm) x Ø 1/2" (12 mm) copper Ø 5/16" (8 mm) x Ø 3/8" (10 mm)

Cylinder type MTC17510

- Stroke 8⁷/₈" (225 mm)
- Volume 21.7 cu.inch (356 cm³)
- Length of tiller arm 7³/₄" (196 mm)
- Weight 17.6 lbs (8 kg)



N/A

N/A

Wheel turns 8.5

- Max. Torque **1717Nm (175kgm)** (1266ft.lbs).
- Torque at 35° and 56kg/cm²: 1373Nm (140kgm) (1013ft.lbs)
- Tubing: nylon hose Ø 1/4" (6 mm) x Ø 3/8" (10 mm) or Ø 5/16" (8 mm) x Ø 1/2" (12 mm) copper Ø 5/16" (8 mm) x Ø 3/8" (10 mm)



CYLINDERS

Hydraulic steering cylinder

For transom hung rudders

Specifications

- Stroke 8⁷/₈" (225 mm)
- Volume 8.9 cu.inch (146 cm³)
- Length of arm 7³/₄" (196 mm)

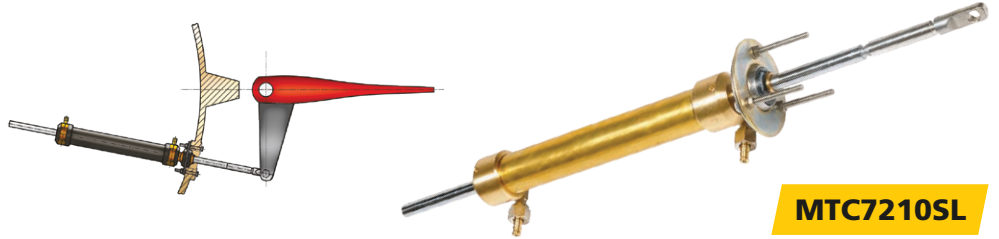

MTC7210SL

Type

MTC7210SL Cylinder type MTC72SL for transom hung rudders

Hydraulic steering kit

An attractive solution for smaller boats

This kit includes:

- Pump type HTP2010 (white)
- Cylinder type MTC3008
- Nylon hose 49" (15 mtr.) type HS04N
- Hydraulic steering oil 1 ltr type VHS1
- All required fittings

Specifications

- Max. torque 294Nm (30 kgm, 216 ft.lbs)
- Wheel turns 3,4
- Stroke 150 mm
- Volume 4.1 cu.inch (67 cm³)
- Length of tiller arm 5¹/₁₆" (129 mm)



MTC30KIT

Type

MTC30KIT Hydraulic steering kit including cylinder (MTC30), pump (HTP2008), nylon tubing (15 metres), fittings and oil

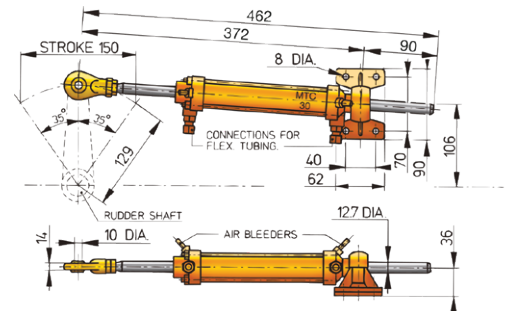

STEERING PUMPS

Tilting steering pumps type HTPT

For both seated and standing steering positions

Type HTPT has a tilt mechanism which allows the steering wheel to be locked in 5 different positions with a total tilt range of 48°. The steering wheel shaft is made of stainless steel (AISI 316) and all other visible parts are made of black rubber and synthetic material. These pumps are supplied with built-in non-return valves, a pressure relief valve and feature the same specifications as steering pump type HTPR.



HTP.T

Type	Colour	Ø inches (mm) tubing	Capacity in ³ (cm ³)/rev.	Number of pistons
HTP2008T	Black	5/16	1,2 (19,7)	5
HTP2010T	Black	3/8	1,2 (19,7)	5
HTP3008T	Black	5/16	1,8 (30,0)	5
HTP3010T	Black	3/8	1,8 (30,0)	5
HTP4210T	Black	3/8	2,6 (42,7)	7

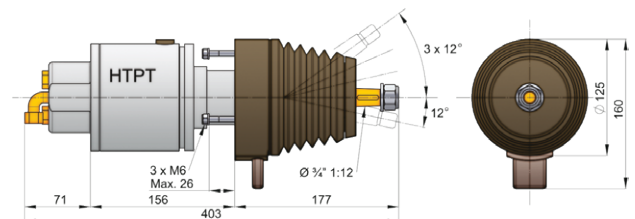

STEERING SYSTEMS FOR COMMERCIAL CRAFT

Type MT0230B / MT0345B / MT0455B / MT0600B / MT0900B / MT1200B

The best possible combination

Choosing the right combination of pump and cylinder can be quite difficult. VETUS pumps and cylinders are fully compatible, enabling the builder and owner to choose the best combination of price and number of wheel turns lock to lock. The smaller the pump unit, the lower the price but also the higher the number of turns. However, the choice of cylinder is always determined by the rudder torque. Please see tables below for determination of the wheel turns.

Specifications

- Available for single and dual station control
- Cylinders are supplied with flexible hose tails, bleed nipples (which accept a quick-release coupling for rapid bleeding) and a base plate with universal joint and a swivelling rod end
- Axial plunger pumps with 7 plungers
- 25 mm / 1" diameter Stainless steel (AISI 316) steering wheel shaft (extra strong for large steering wheels)
- Cylinder and pump can be supplied separately



MTP151B

MTP191B



MTP089B

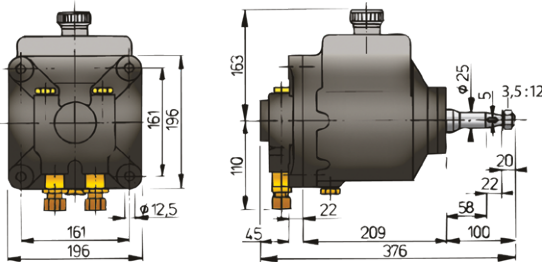

MTP0151B
MTP191B

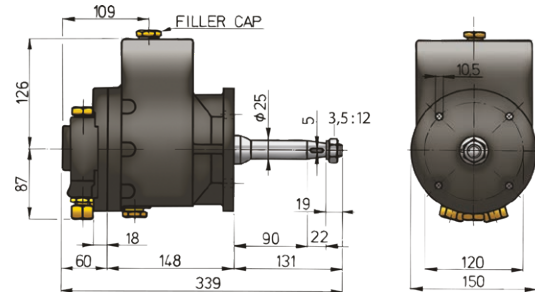

MTP089B

Specifications pump units	MTP089B	MTP151B	MTP191B
Capacity of pump unit	(5 ⁷ / ₁₆ cu.inch/rev) 89 cm ³ /rev.	(9 ⁷ / ₃₂ cu.inch/rev) 151 cm ³ /rev.	(11 ² / ₃₂ cu.inch/rev) 191 cm ³ /rev.
Number of pistons	7	7	7
Maximum pressure	63 kg/cm ² (6178 kPa) (896 lbs/sq. inch)		
Dimensions of tubes	Ø 18 mm x 15 mm		
Connections	G 1/2 female pipe thread		
Weight of pump unit	20 lbs (9,1 kg)	50,7 lbs (23 kg)	50,7 lbs (23 kg)
Min. steering wheel diameter	25 1/2" (65 cm)	43 1/4" (110 cm)	53 1/8" (135 cm)



STEERING SYSTEMS FOR COMMERCIAL CRAFT



MT1200B



MT0230B

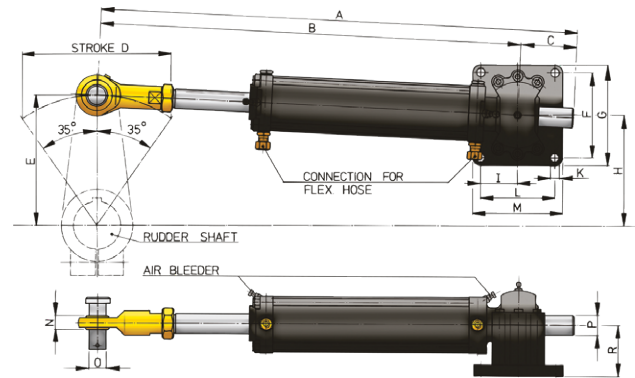

MT0230B - MT1200B

Cylinder	A	B	C	D	E	F	G	H	I	K	L	M	N	O	P	R
MT0230B	733 (28 ³ / ₈ "	607 (23 ⁷ / ₁₆ "	127 (5"	200 (7 ⁷ / ₈ "	175 (6 ⁵ / ₈ "	112 (4 ¹³ / ₃₂ "	140 (5 ¹ / ₂ "	143 (5 ⁵ / ₈ "	36 (1 ¹³ / ₃₂ "	11 (⁷ / ₁₆ "	72 (2 ⁷ / ₃₂ "	100 (3 ¹⁵ / ₁₆ "	31 (1 ¹ / ₃₂ "	25 (1"	28 (1 ¹ / ₆₄ "	55 (2 ¹ / ₃₂ "
MT0345B	933 (36 ⁴ / ₁₆ "	757 (29 ²³ / ₆₄ "	177 (7"	300 (11 ¹³ / ₁₆ "	260 (10 ¹⁵ / ₆₄ "	112 (4 ¹³ / ₃₂ "	140 (5 ¹ / ₂ "	215 (8 ¹⁵ / ₃₂ "	36 (1 ¹³ / ₃₂ "	11 (⁷ / ₁₆ "	72 (2 ⁷ / ₃₂ "	100 (3 ¹⁵ / ₁₆ "	31 (1 ¹ / ₃₂ "	25 (1"	28 (1 ¹ / ₆₄ "	55 (2 ¹ / ₃₂ "
MT0455B	1133 (44 ²⁹ / ₆₄ "	907 (35 ²³ / ₆₄ "	227 (8 ¹⁵ / ₁₆ "	400 (15 ³ / ₄ "	350 (13 ²⁵ / ₃₂ "	112 (4 ¹³ / ₃₂ "	140 (5 ¹ / ₂ "	286 (11 ¹ / ₄ "	36 (1 ¹³ / ₃₂ "	11 (⁷ / ₁₆ "	72 (2 ⁷ / ₃₂ "	100 (3 ¹⁵ / ₁₆ "	31 (1 ¹ / ₃₂ "	25 (1"	28 (1 ¹ / ₆₄ "	55 (2 ¹ / ₃₂ "
MT0600B	735 (29"	695 (27 ²³ / ₆₄ "	40 (1 ³ / ₁₆ "	200 (7 ⁷ / ₈ "	175 (6 ⁷ / ₈ "	160 (6 ³ / ₈ "	198 (7 ⁵ / ₁₆ "	143 (5 ⁵ / ₈ "	71,5 (2 ¹³ / ₁₆ "	18,5 (²³ / ₃₂ "	143 (5 ⁵ / ₈ "	182 (7 ¹ / ₁₆ "	25 (1"	35 (1 ³ / ₈ "	40 (1 ³ / ₁₆ "	102 (4"
MT0900B	935 (36 ¹³ / ₁₆ "	845 (33 ¹⁷ / ₆₄ "	90 (3 ³⁵ / ₆₄ "	300 (11 ¹³ / ₁₆ "	260 (10 ¹ / ₄ "	160 (6 ³ / ₈ "	198 (7 ⁵ / ₁₆ "	215 (8 ¹⁵ / ₃₂ "	71,5 (2 ¹³ / ₁₆ "	18,5 (²³ / ₃₂ "	143 (5 ⁵ / ₈ "	182 (7 ¹ / ₁₆ "	25 (1"	35 (1 ³ / ₈ "	40 (1 ³ / ₁₆ "	102 (4"
MT1200B	1135 (44 ⁷ / ₈ "	995 (39 ¹¹ / ₆₄ "	140 (5 ¹ / ₂ "	400 (15 ³ / ₄ "	350 (13 ³ / ₄ "	160 (6 ³ / ₈ "	198 (7 ⁵ / ₁₆ "	286 (11 ¹ / ₄ "	71,5 (2 ¹³ / ₁₆ "	18,5 (²³ / ₃₂ "	143 (5 ⁵ / ₈ "	182 (7 ¹ / ₁₆ "	25 (1"	35 (1 ³ / ₈ "	40 (1 ³ / ₁₆ "	102 (4"

Theoretical number of steering wheel turns from starboard to port

Pump unit	Cylinder					
	MT0230B	MT0345B	MT0455B	MT0600B	MT0900B	MT1200B
MTP089B	5.6	8.4	11.2	14.8	22.2	29.6
MTP151B	3.3	5.0	6.6	8.8	13.1	17.5
MTP191B	2.6	3.9	5.2	6.9	10.4	13.8

Technical data cylinders

	MT0230B	MT0345B	MT0455B	MT0600B	MT0900B	MT1200B
Max torque at 35° rudder angle	1628 ft. lbs. 2207 Nm (225 kgm)	2460 ft. lbs. 3335 Nm (340 kgm)	3256 ft. lbs. 4415 Nm (450 kgm)	4341 ft. lbs. 5886 Nm (600 kgm)	6512 ft. lbs. 8829 Nm (900 kgm)	8683 ft. lbs. 11772 Nm (1200 kgm)
Cylinder stroke	7 ⁷ / ₈ " (200 mm)	11 ¹³ / ₁₆ " (300 mm)	15 ³ / ₄ " (400 mm)	7 ⁷ / ₈ " (200 mm)	11 ¹³ / ₁₆ " (300 mm)	15 ³ / ₄ " (400 mm)
Max. pressure	6178 kPa (63 kg/cm ²) (896 lbs/sq.inch)					
Cylinder volume	30 ¹ / ₂ cu.inch ³ (500 cm ³)	45 ⁴⁹ / ₆₄ u.inch ³ (750 cm ³)	61 cu.inch ³ (1000 cm ³)	80 ¹ / ₂ cu.inch ³ (1319 cm ³)	120 ⁴⁵ / ₆₄ cu.inch ³ (1978 cm ³)	161 cu.inch ³ (2638 cm ³)
Total rudder angle	70°					
Length of tiller arm	6 ⁷ / ₈ " (175 mm)	10 ¹⁵ / ₆₄ " (260 mm)	13 ²⁵ / ₃₂ " (350 mm)	6 ⁷ / ₈ " (175 mm)	10 ¹⁵ / ₆₄ " (260 mm)	13 ²⁵ / ₃₂ " (350 mm)
Weight of cylinder	30.4 lbs (13,8 kg)	35 lbs (15,9 kg)	40 lbs (18 kg)	77.4 lbs (35,1 kg)	85.5 lbs (38,8 kg)	93.5 lbs (42,5 kg)
Dimensions of tubes	Ø 18 mm x 15 mm					
Connections	All connections are provided with G 1/2 female pipe thread.					

Also available for single and dual steering

Type	Description
HS81B	Dual non-return valve (G1/2) (incl. tube connectors Ø 18 mm)
HS74B	Single non-return valve (G1/2) with by-pass valve (incl. tube connectors Ø 18 mm) (suitable for single and dual station)
HS42B	Pressure relief valve (G1/2) (incl. tube connectors Ø 18 mm)

STEERING SYSTEMS FOR OUTBOARD ENGINES/Z-DRIVES

A VETUS outboard engine/Z-drive steering system consists of a steering pump with non-return and pressure relief valves and a cylinder. The cylinder is connected to the pump with nylon hydraulic hose. VETUS offers 5 different types of hydraulic cylinders suitable for outboard motors with an output of 90 KW (125hp) up to 220 KW (300hp).

OBC cylinders

Specifications

- Balanced cylinder
- Supplied with combined $\text{Ø } \frac{3}{8}$ " (10 mm) hose connections and bleed nipples
- Piston rod with scraper seals preventing damage from salt and dirt and T-pieces to connect the cylinders



Required components to order separately

- 1 or 2 cylinders type OBC or MTC (see page 252 for max. engine hp possibilities)
- 1 or 2 steering pumps with built-in non-return valves, type HTPR
- Length of hydraulic hose $\text{Ø } \frac{3}{16}$ " x $\frac{1}{2}$ " (8 x 12 mm), type HHOSE8
- Straight or right angle hose connectors
- Hydraulic fluid
- T-pieces for $\text{Ø } \frac{3}{8}$ " (10 mm) pipe (when more than 1 pump or cylinder is installed)

Type	Max. hp
OBC125	125
OBC150	150
OBC225	225
OBC275	300
MTC100Z	300

OB1000 Tie bar

For connecting 2 outboard motors up to 300 hp each

The tie bar has adjustable ends and connection bolts ($\frac{3}{8}$ " UNF). The maximum centre-to-centre distance between the steering arms is 915mm. The bar can be easily cut to the required length. All components of the tie bar are made of stainless steel (AISI 316).

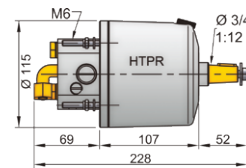
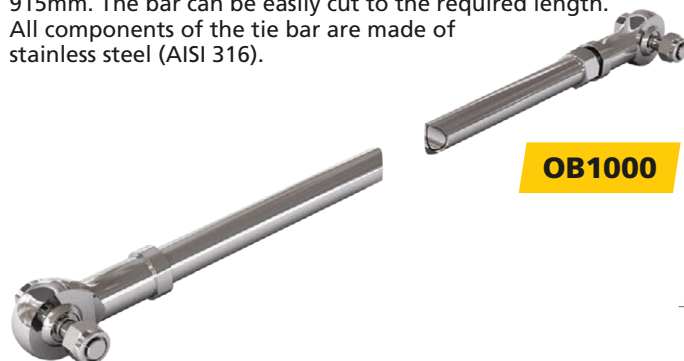

HTP2010R / RB
HTP3010R / RB
HTP4010R / RB

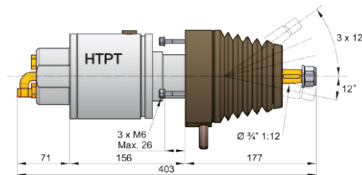

HTP2010T
HTP3010T
HTP4010T

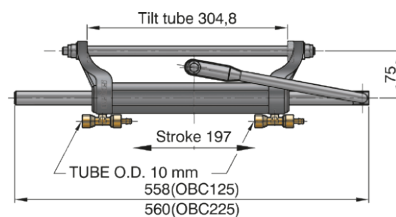

OBC125
OBC225

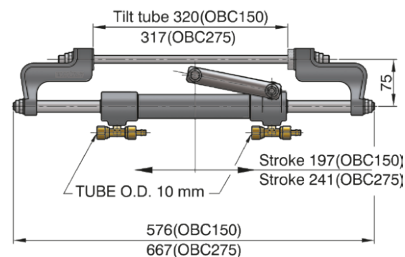

OBC150
OBC275

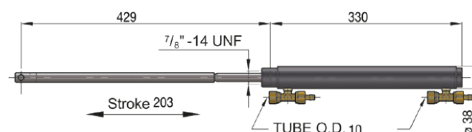

MTC100Z



STEERING SYSTEMS FOR OUTBOARD ENGINES/Z-DRIVES

Specifications

- Maximum operating pressure 70 bar
- Connections G 1/4" - Ø 3/8" (10 mm)
- Nylon hose Ø 5/16" (8 mm) x Ø 1/2" (12 mm)
- Pump fitting Front Mount

- Capacity 1.2 in³/rev.
- Number of pistons 5
- Weight 9.4 lbs (4,1 kg)

- Capacity: 1.8 in³/ rev.
- Number of pistons 5
- Weight 9.4 lbs (4,1 kg)

- Capacity: 2.6 in³/ rev.
- Number of pistons 7
- Weight: 9.4 lbs (4,1 kg)



HTP2010R



HTP3010R



HTP4210R

OBC125

- Maximum rudder torque 643 Nm (475 ft.lbs)
- Volume 6.6 in³
- Maximum output 90 kW (125 hp)
- Maximum speed 85 km/h (45 knots)



Wheels turns port - starboard: 5,5

Wheels turns port - starboard: 3,6

N/A

OBC125 the piston rod moves inside the cylinder

OBC225

- Maximum rudder torque 1026 Nm (757 ft.lbs)
- Volume 10.5 in³
- Maximum output 165 kW (225 hp)
- Maximum speed 85 km/h (45 knots)



Wheels turns port - starboard: 8,8

Wheels turns port - starboard: 5,8

Wheels turns port - starboard: 4,1

OBC225 the piston rod moves inside the cylinder

OBC150

- Maximum rudder torque 643 Nm (475 ft.lbs)
- Volume 6.6 in³
- Maximum output 110 kW (150 hp)
- Maximum speed 85 km/h (45 knots)



Wheels turns port - starboard: 5,5

Wheels turns port - starboard: 3,6

N/A

OBC150 the cylinder moves over the piston rod

OBC275

- Maximum rudder torque 788 Nm (581.5 ft.lbs)
- Volume 8.1 in³
- Maximum output 220 kW (300 hp)
- Maximum speed: 110 km/h (60 knots)



Wheels turns port - starboard: 6,8

Wheels turns port - starboard: 4,4

Wheels turns port - starboard: 3,2

OBC275 the cylinder moves over the piston rod

MTC100Z

- Maximum rudder torque 989 Nm (730 ft.lbs)
- Volume 8.1 in³ / 10.0 in³
- Maximum output 220 kW (300 hp)
- Maximum speed: 95 km/h (50 knots)



Wheels turns port - starboard: 8,3

Wheels turns port - starboard: 5,4

Wheels turns port - starboard: 3,9

MTC100Z for Z-drives and outboard engines

For accessories see page 253.

A single cylinder can operate a **twin** outboard motor installation. If both propellers rotate in the same direction, the total engine output may not exceed the maximum capacity of the selected cylinder. If the motors have handed (counter-rotating) propellers, the total combined output may be twice the rated capacity of the chosen cylinder.

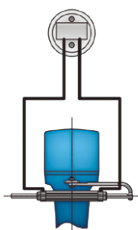

Single steering position for 1 engine

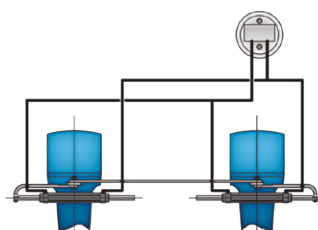

Single steering position for 2 engines

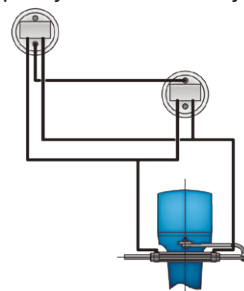

Dual steering position for 1 engine

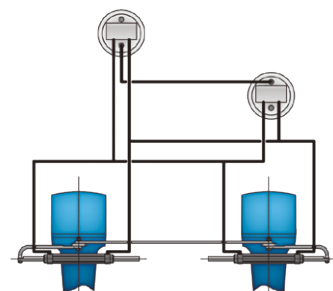

Dual steering position for 2 engines

ACCESSORIES FOR STEERING SYSTEMS

Telescopic steering wheel adjuster type HS

Enhancing your steering comfort

This telescopic steering wheel adjuster is suitable for hydraulic steering pumps type HTP and HTPR. It is fitted to the steering pump, enhancing your steering comfort in both seated and standing positions. Maximum travel of 3 1/2" (90 mm) (adjustable in 3 steps of 1 3/16" (30 mm)).

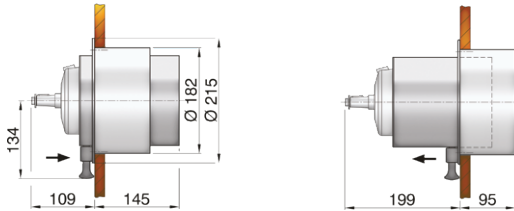

HS1000

Type	Description
HS1000	Telescopic steering wheel adjuster for HTP type pumps (excl. pump)

Pump flanges type HTPF

Embellishment for your pump

These polished stainless steel (AISI 316) flanges can be used to fit pump type HTP (or to replace older type MTP) and to recess your pump by 1 1/2" (38 mm) (type HTPF) or 2 15/16" (74 mm) (type HTPF2). It can also be used to give your pump a more refined look.

On an outside helm station, with a pump mounted on an inclined bulkhead or sloping dashboard, the housing of the telescopic wheel adjuster may catch water. To prevent this water entering the boat, a seal set is recommended (Type HTPF3).

Type	Description
HTPF	Adaptor flange, stainless steel (AISI 316) for HTP pump, 1 1/2" (38 mm) depth
HTPF2	Adaptor flange, stainless steel (AISI 316) for HTP pump, 2 15/16" (78 mm) depth
HTPF3	Waterproof seal kit for HTP pump in a HTPF flange



HTPF



HTPF2



HTPF3



ACCESSORIES FOR STEERING SYSTEMS

Dual non-return valve

This dual non-return valve block has to be installed when dual station steering is required and the pumps do not have integral non-return valves. Alternatively, you can use 2 steering pumps with built-in non-return valves type HTPR. This is also the case when an electro-hydraulic pump needs to be installed when fitting an autopilot and the installed steering pumps do not have integral non-return valves.

The connection kit must be ordered separately and is not included with the K30/140B.

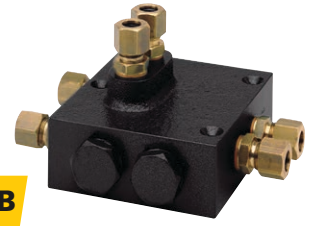

K30/140B

Type	Description
K30/140B	Dual non-return valve block without fittings used with cylinders MTC3008 to MTC17510
KITK30	Connection kit, 5/16" (8 mm), to be used with K30/140B and MTC3008
KITK52175	Connection kit, 3/8" (10 mm), to be used with K30/140B and MTC5210 - MTC17510

KITK30



KITK52175

By-pass valve

If a quick change-over to tiller steering has to be done in case of an emergency, installation of a by-pass valve is necessary.

Type	Tubing Ø inches (mm)
BYPASS8	5/16 (8)
BYPASS10	3/8 (10)
BYPASS18	1 1/16 (18)



BYPASS

Nylon hose

Type	Internal Ø inches (mm)	External Ø inches (mm)	Length in rolls of feet (m)	Required connection parts
HS04N	1/4 (6)	5/16 (8)	49 (15)	HS1011S Sleeve insert (20 pieces)
HHOSE6015	1/4 (6)	3/8 (10)	49 (15)	HS145S Sleeve insert (20 pieces)
HHOSE6030	1/4 (6)	3/8 (10)	98 (30)	HS145S Sleeve insert (20 pieces)
HHOSE6050	1/4 (6)	3/8 (10)	164 (50)	HS145S Sleeve insert (20 pieces)
HHOSE6100	1/4 (6)	3/8 (10)	328 (100)	HS145S Sleeve insert (20 pieces)



HHOSE

Type	Internal Ø inches (mm)	External Ø inches (mm)	Length in rolls of feet (m)	Required connection parts
HHOSE8015	5/16 (8)	1/2 (12)	49 (15)	HS1031MS (straight, set of 2 pieces) / HS1037MS (angled, set of 2 pieces)
HHOSE8030	5/16 (8)	1/2 (12)	98 (30)	HS1031MS (straight, set of 2 pieces) / HS1037MS (angled, set of 2 pieces)
HHOSE8050	5/16 (8)	1/2 (12)	164 (50)	HS1031MS (straight, set of 2 pieces) / HS1037MS (angled, set of 2 pieces)
HHOSE8100	5/16 (8)	1/2 (12)	328 (100)	HS1031MS (straight, set of 2 pieces) / HS1037MS (angled, set of 2 pieces)

ACCESSORIES FOR STEERING SYSTEMS

Connection parts

When using compression fittings supplied as standard with non-commercial pumps and cylinders, a brass sleeve must be inserted into each end of the nylon hose in order to maintain hose circularity. An alternative connection method for 8 x 12 nylon hose is to use barbed connections HS1031MS and HS1037MS.

Type	Description
HS10131	Sleeve insert \varnothing 1/4" and olive, \varnothing 5/16" for use with HS04N nylon hose, pack of 10 pcs
HS1011S	Sleeve insert, \varnothing 1/4", for use with HS04N, set of pack of 20 pcs
HS145S	Sleeve insert, \varnothing 1/4", for use with nylon hose (HHOSE6...), pack of 20 pcs
HS1031MS	Straight brass hose connector for nylon hose \varnothing 5/16" x 1/2" (HHOSE8..), pack of 2 pcs
HS1037MS	Right angle brass hose connector for nylon hose \varnothing 5/16" x 1/2" (HHOSE8..), pack of 2 pcs



HS1011S



HS145S



HS10131



HS1031MS



HS1037MS

Copper tubing

Copper tubing is available per roll in 3 different sizes.

Type	Internal \varnothing inches (mm)	External \varnothing inches (mm)	Length feet (m)	Required connection parts
COPPER08	1/4" (6)	5/16" (8)	52 (16)	MTC610 Flexible hose tail set
COPPER10	5/16" (8)	3/8" (10)	65 (20)	MTC810 Flexible hose tail set
COPPER18	9/16" (15)	11/16" (18)	32 (10)	N/A



COPPER

VETUS hydraulic steering oil type VHS1

Optimal functioning in all temperatures

For more information see page 409.

VHS



Hydraulic fluid header tank type HTANK

This transparent tank can be installed with all VETUS steering pumps up to 5.4 cu.inch (89 cm³) per revolution. It is also recommended for electro-hydraulic hatch lifters when operating more than 1 cylinder. By installing this reservoir tank, the breather plug in the steering pump can be replaced with the supplied solid plug, eliminating the possibility of steering fluid dribbling from the breather in big seas.

Specifications

- Capacity 12.2 cu.inch (200 cm³)
- Supplied with a large mounting bracket
- Comes with 1mtr of \varnothing 5/16" (8 mm) hose, 2 matching hose clips, 1 G1/4 and 1 G3/8 nylon hose pillar

Type	Description
HTANK	Expansion tank kit for hydraulic steering systems



HTANK



RUDDERS

Type RUDS

These rudders with stainless steel (AISI 316) blade come complete with a rudder arm to which a VETUS hydraulic steering cylinder can be connected. The blade sides are polished and need no additional finishing. The stainless steel (AISI 316) rudder stock is provided with a hole to facilitate the fitting of an emergency tiller. Type RUDS comes in 2 heights.

Specifications type RUDS4040

- Dimensions w 15³/₄" x h 15³/₄" (400 x 400 mm) (excl. rudder arm)
- Speed with cylinder MTC30 30 knots, MTC52 42 knots

Specifications type RUDS5040

- Dimensions w 15³/₄" x h 19¹¹/₁₆" (400 x 500 mm) (excl. rudder arm)
- Speed with cylinder MTC30 27 knots, MTC52 34 knots

A rudder gland may be supplied as an extra (type HENKO only)

Type	Width inches (mm)	Height inches (mm)
RUDS4040	15 ³ / ₄ (400), excl. rudder arm	15 ³ / ₄ (400)
RUDS5040	15 ³ / ₄ (400), excl. rudder arm	19 ¹¹ / ₁₆ (500)

	RUDS4040	RUDS5040
With cylinder MTC30	30 knots	27 knots
With cylinder MTC52	42 knots	34 knots

The indicated speed figures are the maximum permissible speeds.

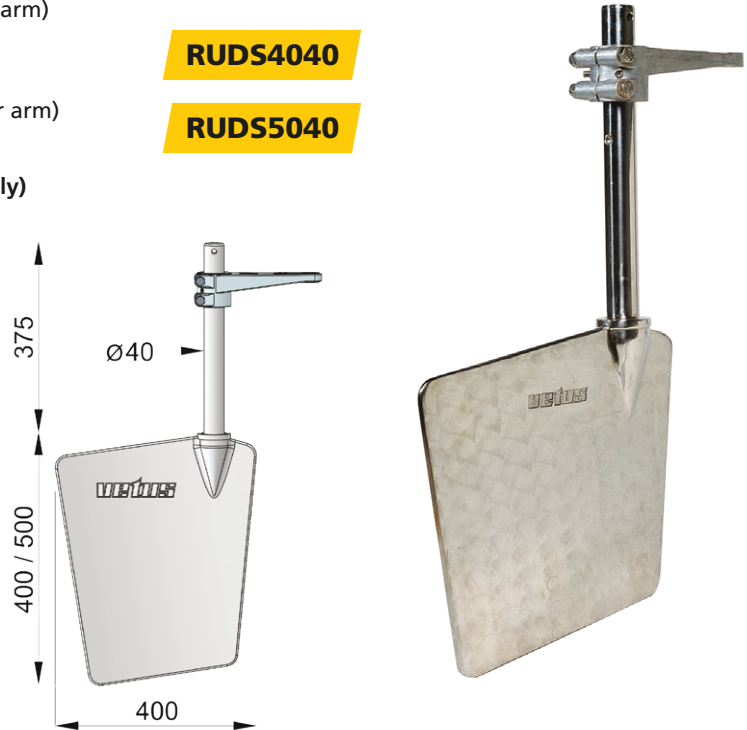

Aluminium rudder arms type HELM

These rudder arms are available for \varnothing 1³/₁₆"', 1⁹/₁₆"', 2" or 2³/₈" (30, 40, 50 or 60 mm) rudder stocks. They are connected by 2 clamp bolts. The \varnothing 1³/₁₆" (30 mm) and 1⁹/₁₆" (40 mm) rudder arms have 2 locking grub screws onto the shaft and feature 4 attachment points for the steering cylinder making them suitable for VETUS hydraulic cylinders type MTC30/52 and 72. The \varnothing 2" (50 mm) and 2³/₈" (60 mm) rudder arms have a stainless steel (AISI 316) key and feature 3 attachment points which match type MTC125/175 and 230. For connecting VETUS cylinder types MTC30/175 matching bolt sets are available.

Type	\varnothing D	H
HELM30	30	56
HELM40	40	66

Type	\varnothing D	H
HELM50	50	66
HELM60	60	76

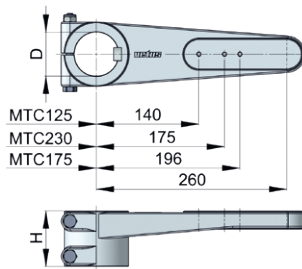
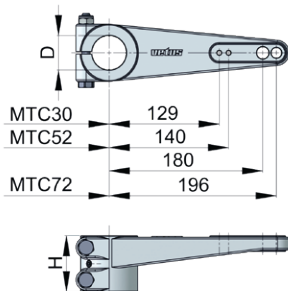

HELM

RUDDERS

Rudder gland type HENKO

This bronze rudder gland is available in 2 different lengths for $\varnothing 1\frac{3}{16}$ " (30 mm) or $\varnothing 1\frac{9}{16}$ " (40 mm) rudder stocks.

Type	$\varnothing D$	L	A	$\varnothing B$	C
HENKO30	$1\frac{3}{16}$ "	$6\frac{57}{64}$ "	$1\frac{19}{32}$ "	$2\frac{9}{16}$ "	-
HENKO30L	7.9 gal.	$10\frac{53}{64}$ "	$1\frac{19}{32}$ "	$2\frac{9}{16}$ "	$5\frac{5}{16}$ "
HENKO40	$1\frac{9}{16}$ "	$8\frac{5}{64}$ "	$4\frac{3}{64}$ "	$3\frac{5}{32}$ "	-
HENKO40L	10.5 gal.	12"	$4\frac{3}{64}$ "	$3\frac{5}{32}$ "	$5\frac{5}{16}$ "

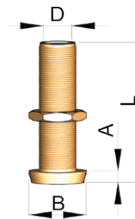
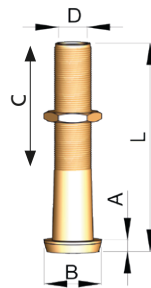

HENKO..L

HENKO

REMOTE CONTROL STEERING

Follow-up steering

Suitable for boats of 18 ft. - 60 ft. (6 - 20 metres) LOA

Many pleasure craft are equipped with a manual hydraulic steering system. The VETUS follow-up steering system can be added to enable remote control from any position on board without the need to mount and connect a steering wheel. This greatly facilitates adding an inside steering station in a finished and furnished space. This system comes from a type of steering that is in common use with professional waterways vessels. By simply turning the steering handle, the rudder will follow the exact angle of the handle and by returning the handle to the mid-position, the rudder will return to mid-ships. Manual steering can be resumed at any time by switching the system off. VETUS' follow-up steering meets the EMC requirements.

Type FUHANDLE with control box type FU1224

Steering from any convenient place on board!

The fixed control handle can operate any type of hydraulic steering system with an electro-hydraulic pump, by means of the control box. It can be mounted on the dashboard or fixed to the helmsman's seat. This type of remote control can be used as the main steering device instead of the steering wheel, or as second or even third steering option.

Specifications

- Panel dimensions $4\frac{5}{16}$ " x $4\frac{23}{32}$ " (110 x 120 mm)
- Dimensions incl. handle $4\frac{5}{16}$ " x $7\frac{1}{2}$ " (110 x 190 mm)
- Height $1\frac{3}{4}$ " (45 mm)

Type	Description
FUHANDLE	Dash mount control handle for follow-up system
FU1224	Control box for follow-up system, 12/24 Volt



FUHANDLE



FU1224

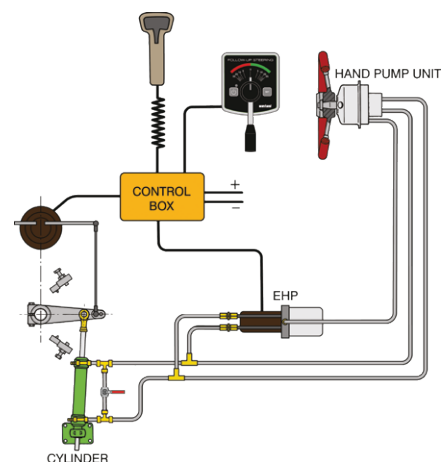

REMOTE CONTROL STEERING

Follow-up control type FUREM

Mobile hand held control

Type FUREM has the same function as fixed control handle type FUHANDLE. However, the control is supplied with a 3 mtr spiralled cable with connection plug and socket. Type FUREM can only be used in addition to the fixed control.

Type	Description	Dimensions control box inches (mm)
FUREM	Hand operated remote control for follow-up system	10 ³ / ₁₆ x 4 ⁵ / ₁₆ x 2 ¹ / ₁₆ (258 x 114 x 52)

FUREM

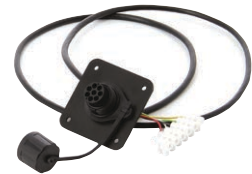

Electric remote control type RECON

Easy and affordable expansion of your steering system

Conventional wheel operated hydraulic systems can be easily and cheaply equipped with this electrically operated remote control unit from virtually any point on board. Type RECON consists of a rocker switch, a 3,5 mtr spiralled wire with watertight plug and deck contact. An electro hydraulic pump is fitted in the hydraulic system and connected to the DC power supply. The hand held remote control is then used to operate the pump in the required direction.

Required components to order separately

- Electro hydraulic pump
- Hydraulic fitting set for pump
- Hydraulic tubing of the required length
- 1 or more hand held controls with spiralled wire
- 2 Limit switches for the hydraulic cylinder

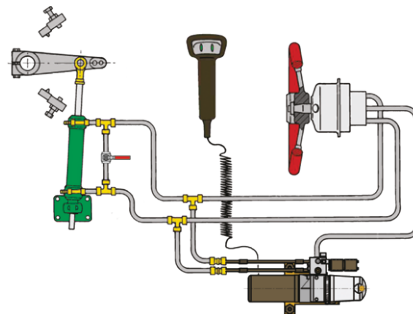

RECON



Type	Description
RECON	Hand held remote control for operation of: bow and stern thrusters, windlasses, etc.

Set of limit switches

To avoid damage to the steering system components, the action of any electronic or electrical steering system should be tempered by limit switches located at the rudder stops.

EHPESET

Type	Description
EHPESET	Set of limit switches (2 pieces)



GLAZING SYSTEMS

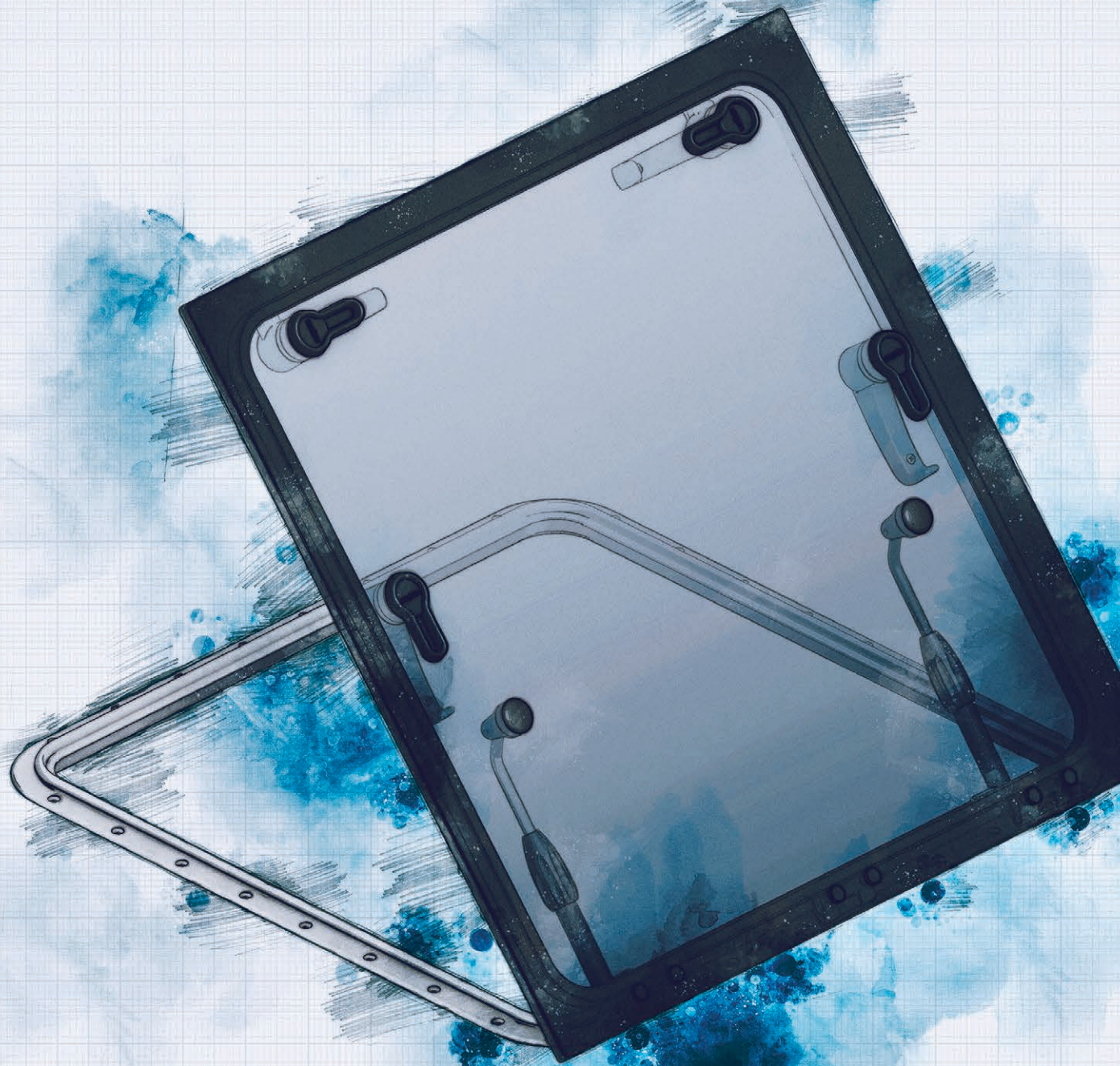

- 
- 
- 
- 
- 
- 
- 
- 
- 
- 
- 
- 
- 
- 
- 
-

Overview VETUS glazing systems

Portholes see page 263



Escape and ventilation hatches see page 268



Hatch trims with mosquito screen

see page 269



Custom made glazing products see page 274



Fly Bridge Hatch

see page 277



Windscreen wipers, arms and blades see page 279



Clear view screens

see page 282



Accessories see page 284



VETUS GLAZING PRODUCTS

VETUS has produced glazing products for over 50 years. Over these years we have gained a huge amount of knowledge and experience, giving us the ability to offer the best quality at the most competitive price. To maintain this leadership position we are constantly monitoring and improving the production processes.

Whether you need a windscreen wiper system, a flush hatch or a custom window, our dedicated glazing team will be there to provide you with solid advice and excellent after-sales service.

Why use VETUS glazing products?

- We provide a complete solution to all your marine glazing requests
- Competitive price/quality ratio
- We offer a wide range of standard and custom made windows, portholes and hatches
- All portholes are delivered with a mosquito screen as a standard
- High quality marine wipers featuring a powerful electric motor and separate worm wheel transmission
- Uniform appearance of all glazing components
- All hatches and portholes are CE marked in accordance with the Recreational Craft Directive
- All windows, windscreens, doors and cabin entries have been tested according to ISO 12216



CE MARKING

By affixing the CE marking to our products we declare that our products are in conformity with the applicable directives; such as for example the Recreational Craft Directive. Specific requirements for windows, portlights, hatches, deadlights and doors are given in ISO 12216. Naturally our complete range of glazing products comply with this standard. The criteria to be met depend on the design category (A, B, C or D) of the boat and on the area where the port, hatch etc. must be installed in the boat. There is always a VETUS product that is tested and certified to suit your situation. If you require advice about the correct product to choose, please contact VETUS or your VETUS dealer.

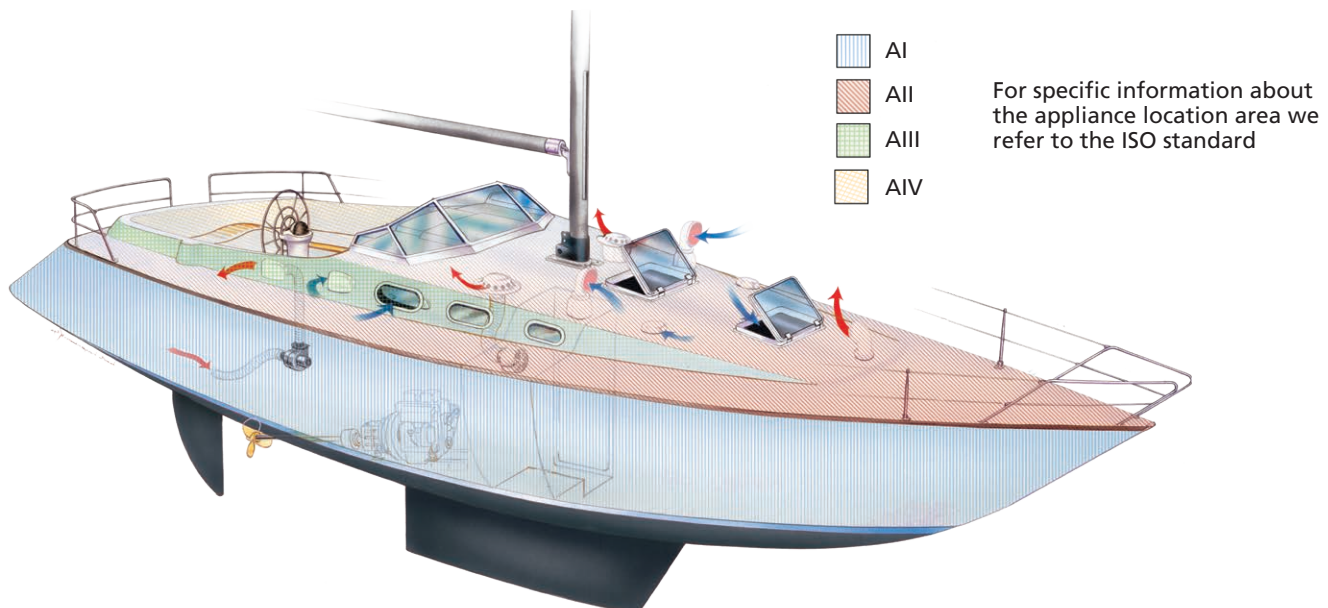

PORTHOLES

Portholes (AI)

Heavy duty portholes

These portholes are suitable for use in the hull side. The $\frac{3}{8}$ " (10 mm) 'smoke' coloured opening pane is set in a satin anodised aluminium frame. Black or white powder coated frames are optional. The clamp fixing ensures that no fasteners are visible from either inside or outside. The portholes can be held open in any position due to the friction type hinges. In the closed position knobs ensure complete water tightness. The porthole can be fitted in a surface with a minimum thickness of $\frac{1}{16}$ " (2 mm) and a maximum thickness of $\frac{11}{16}$ " (18 mm). As standard a mosquito screen is supplied. A fixed version of each opening porthole is also available to special order.

Type PM (AI)

Type	External dimensions A x B inches (mm)	Cut-out dimensions C x D inches (mm)	Cut-out radius R inches (mm)	Type mosquito screen
PM111	9 ³⁹ / ₆₄ x 5 ³ / ₄ (244 x 146)	8 ²¹ / ₃₂ x 4 ⁵¹ / ₆₄ (220 x 122)	2 ¹³ / ₃₂ (61)	HOR11
PM121	11 ³⁷ / ₆₄ x 6 ⁴⁹ / ₆₄ (294 x 172)	10 ⁵ / ₈ x 5 ⁵³ / ₆₄ (270 x 148)	2 ²⁹ / ₃₂ (74)	HOR12
PM131	13 ¹⁷ / ₃₂ x 7 ⁵¹ / ₆₄ (344 x 198)	12 ¹⁹ / ₃₂ x 6 ²⁷ / ₃₂ (320 x 174)	3 ²⁷ / ₆₄ (87)	HOR13
PM141	4 ¹ / ₄ x 5 ³ / ₄ (362 x 146)	13 ⁵ / ₁₆ x 4 ⁵¹ / ₆₄ (338 x 122)	2 ¹³ / ₃₂ (61)	HOR14
PM151	15 ²³ / ₆₄ x 8 ²¹ / ₃₂ (390 x 220)	14 ¹³ / ₃₂ x 7 ²³ / ₃₂ (366 x 196)	3 ⁵⁵ / ₆₄ (98)	HOR15
PM161	15 ⁴⁵ / ₆₄ x 7 ⁵³ / ₆₄ (399 x 199)	14 ³ / ₄ x 6 ⁵⁷ / ₆₄ (375 x 175)	3 ²⁷ / ₆₄ (87)	HOR16

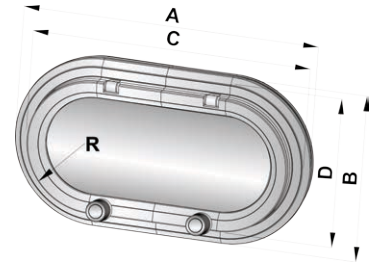

PM

Type PZ (AI)

Type	External dimensions A x B inches (mm)	Cut-out dimensions C x D inches (mm)	Cut-out radius R inches (mm)	Type mosquito screen
PZ611	11 ²⁷ / ₃₂ x 6 ²⁹ / ₆₄ (301 x 164)	10 ²⁹ / ₃₂ x 5 ³³ / ₆₄ (277 x 140)	2 ¹ / ₈ (54)	HOR61
PZ621	14 ³¹ / ₆₄ x 7 ³ / ₆₄ (368 x 179)	13 ³⁵ / ₆₄ x 6 ⁷ / ₆₄ (344 x 155)	2 ¹³ / ₃₂ (61)	HOR62
PZ631	24 ³¹ / ₆₄ x 7 ³ / ₄ (622 x 197)	23 ³⁵ / ₆₄ x 6 ¹³ / ₁₆ (598 x 173)	2 ¹³ / ₃₂ (61)	HOR63
PZ641	15 ⁵ / ₈ x 7 ³ / ₄ (397 x 197)	14 ¹¹ / ₁₆ x 6 ¹³ / ₁₆ (373 x 173)	2 ¹³ / ₃₂ (61)	HOR64
PZ651	15 ⁴⁵ / ₆₄ x 7 ³¹ / ₆₄ (399 x 190)	14 ⁴⁹ / ₆₄ x 6 ¹⁷ / ₃₂ (375 x 166)	2 ¹ / ₈ (54)	HOR65
PZ661	15 ⁴⁵ / ₆₄ x 9 ⁷ / ₃₂ (399 x 234)	14 ⁴⁹ / ₆₄ x 8 ¹⁷ / ₆₄ (375 x 210)	2 ¹ / ₈ (54)	HOR66
PZ671	17 ³ / ₄ x 10 ²⁵ / ₃₂ (451 x 274)	16 ¹³ / ₁₆ x 9 ²⁷ / ₃₂ (427 x 250)	2 ¹ / ₈ (54)	HOR67

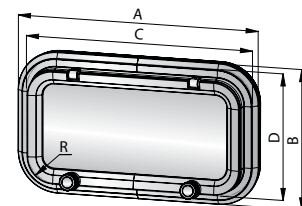

PZ



PORTHOLES

Type PW (AI)

Type	External dimensions A inches (mm) Ø	Cut-out dimensions B inches (mm) Ø	Type mosquito screen
PW201	7 ¹³ / ₁₆ (198)	6 ⁷ / ₈ (174)	HOR2013
PW211	8 ¹¹ / ₁₆ (220)	7 ¹¹ / ₁₆ (196)	HOR2113
PW221	10 ¹ / ₄ (260)	9 ⁵ / ₁₆ (236)	HOR2213



PW

Portholes (AIII)

Medium duty portholes

These portholes are suitable for use in the coachroof side. They come with a 10 mm 'smoke' coloured, unframed opening pane. The clamp type installation ensures that no fasteners are visible from either inside or outside. The portholes can be held open in any position due to the friction type hinges. In the closed position, 2 knobs ensure complete water tightness. As standard a mosquito screen is supplied. The porthole can be fitted in a surface with a minimum thickness of 1/16" (2 mm) and a maximum thickness of 11/16" (18 mm).

Type PM (AIII)

Type	External dimensions A x B inches (mm)	Cut-out dimensions C x D inches (mm)	Cut-out radius R inches (mm)	Type mosquito screen
PM113	9 ⁵ / ₈ x 5 ³ / ₄ (244 x 146)	8 ¹¹ / ₁₆ x 4 ¹³ / ₁₆ (220 x 122)	2 ³ / ₈ (61)	HOR11
PM123	11 ⁹ / ₁₆ x 6 ³ / ₄ (294 x 172)	10 ⁵ / ₈ x 5 ¹³ / ₁₆ (270 x 148)	2 ¹⁵ / ₁₆ (74)	HOR12
PM133	13 ⁹ / ₁₆ x 7 ¹³ / ₁₆ (344 x 198)	12 ⁵ / ₈ x 6 ⁷ / ₈ (320 x 174)	3 ⁷ / ₁₆ (87)	HOR13
PM143	14 ¹ / ₄ x 5 ³ / ₄ (362 x 146)	13 ⁵ / ₁₆ x 4 ¹³ / ₁₆ (338 x 122)	2 ³ / ₈ (61)	HOR14
PM153	15 ³ / ₈ x 8 ¹¹ / ₁₆ (390 x 220)	14 ⁷ / ₁₆ x 7 ¹¹ / ₁₆ (366 x 196)	3 ⁷ / ₈ (98)	HOR15
PM163	15 ⁴⁵ / ₆₄ x 7 ⁵³ / ₆₄ (399 x 199)	14 ³ / ₄ x 6 ⁵⁷ / ₆₄ (375 x 175)	3 ⁷ / ₁₆ (87)	HOR16

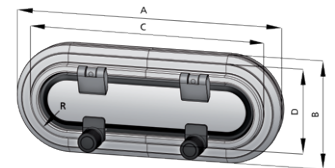

PM

Type PZ (AIII)

Type	External dimensions A x B inches (mm)	Cut-out dimensions C x D inches (mm)	Cut-out radius R inches (mm)	Type mosquito screen
PZ613	11 ⁷ / ₈ x 6 ⁷ / ₁₆ (301 x 164)	10 ⁷ / ₈ x 5 ¹ / ₂ (277 x 140)	2 ¹ / ₈ (54)	HOR61
PZ623	14 ¹ / ₂ x 7 ¹ / ₁₆ (368 x 179)	13 ⁹ / ₁₆ x 6 ¹ / ₈ (344 x 155)	2 ³ / ₈ (61)	HOR62
PZ633	24 ¹ / ₂ x 1 ³ / ₄ (622 x 197)	23 ⁹ / ₁₆ x 6 ¹³ / ₁₆ (598 x 173)	2 ³ / ₈ (61)	HOR63
PZ643	15 ⁵ / ₈ x 1 ³ / ₄ (397 x 197)	14 ¹¹ / ₁₆ x 6 ¹³ / ₁₆ (373 x 173)	2 ³ / ₈ (61)	HOR64
PZ653	15 ¹¹ / ₁₆ x 7 ¹ / ₂ (399 x 190)	14 ³ / ₄ x 6 ⁹ / ₁₆ (375 x 166)	2 ¹ / ₈ (54)	HOR65
PZ663	15 ¹¹ / ₁₆ x 9 ³ / ₁₆ (399 x 234)	14 ³ / ₄ x 8 ¹ / ₄ (375 x 210)	2 ¹ / ₈ (54)	HOR66
PZ673	17 ³ / ₄ x 10 ¹³ / ₁₆ (451 x 274)	16 ¹³ / ₁₆ x 9 ¹³ / ₁₆ (427 x 250)	2 ¹ / ₈ (54)	HOR67

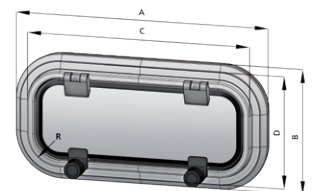

PZ

PORTHOLES

Type PW (AIII)

Type	External dimensions A inches (mm) Ø	Cut-out dimensions B inches (mm) Ø	Type mosquito screen
PW203	7 ¹³ / ₁₆ (198)	6 ⁷ / ₈ (174)	HOR2013
PW213	8 ¹¹ / ₁₆ (220)	7 ¹¹ / ₁₆ (196)	HOR2113
PW223	10 ¹ / ₄ (260)	9 ⁵ / ₁₆ (236)	HOR2213

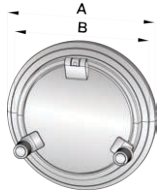

PW

Type PX (AIII)

Type	External dimensions A x B inches (mm)	Cut-out dimensions C x D inches (mm)	Type mosquito screen
PX45	17 ³ / ₈ x 7 ¹ / ₁₆ (441 x 179)	16 ⁷ / ₁₆ x 6 ¹ / ₈ (417 x 155)	HOR45
PX46	19 ³ / ₈ x 7 ¹¹ / ₁₆ (492 x 196)	18 ⁷ / ₁₆ x 6 ³ / ₄ (468 x 172)	HOR46
PX47	21 ⁷ / ₁₆ x 8 ⁹ / ₁₆ (544 x 217)	120 ¹ / ₂ x 7 ⁵ / ₈ (520 x 193)	HOR47
PXF	20 ⁹ / ₁₆ x 8 ⁵ / ₈ (522 x 219)	19 ⁵ / ₈ x 7 ¹¹ / ₁₆ (498 x 195)	HORPXF

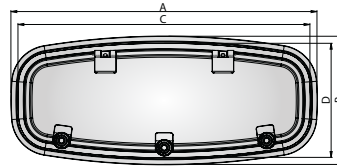
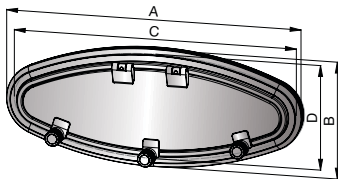

PX



PXF

Stainless steel portholes (AI and AII)

Available in 2 versions

These portholes are suitable for a panel thickness of 1/8" to 1 1/16" (3 to 18 mm). Both versions come with an anodised aluminium mosquito screen (for screw sizes and panel thicknesses see table on following page).

Versions

1. With a stainless steel inner frame, 'smoke' coloured 8 mm acrylic. Appliance location Area I.
2. With unframed 10 mm acrylic, 'smoke' coloured. Appliance location Area II.

Type PWS (AI and AII)

Type	External dimensions A inches (mm) Ø	Cut-out dimensions B inches (mm) Ø	Type mosquito screen
PWS31A2	8 ¹¹ / ₁₆ (220)	7 ¹³ / ₁₆ (198)	HOR31S
PWS31A1	8 ¹¹ / ₁₆ (220)	7 ¹³ / ₁₆ (198)	HOR31S
PWS32A2	10 ¹ / ₄ (260)	9 ³ / ₈ (238)	HOR32S
PWS32A1	10 ¹ / ₄ (260)	9 ³ / ₈ (238)	HOR32S

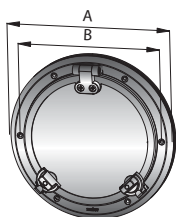

PWS

PORTHOLES

Type PMS (AI and AII)

Type	External dimensions A x B (mm)	Cut-out dimensions C x D (mm)	Type mosquito screen
PMS23A2	13 ⁵ / ₈ x 7 ¹³ / ₁₆ (346 x 199)	12 ¹¹ / ₁₆ x 6 ¹⁵ / ₁₆ (322 x 177)	HOR23S
PMS23A1	13 ⁵ / ₈ x 7 ¹³ / ₁₆ (346 x 199)	12 ¹¹ / ₁₆ x 6 ¹⁵ / ₁₆ (322 x 177)	HOR23S
PMS24A2	15 ³ / ₈ x 7 ¹³ / ₁₆ (390 x 199)	14 ⁷ / ₁₆ x 6 ¹⁵ / ₁₆ (366 x 177)	HOR24S
PMS24A1	15 ³ / ₈ x 7 ¹³ / ₁₆ (390 x 199)	14 ⁷ / ₁₆ x 6 ¹⁵ / ₁₆ (366 x 177)	HOR24S

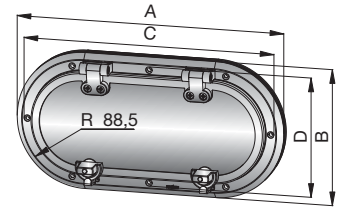

PMS



Recommended screw size for VETUS portholes

Screws available for PWS and PMS portholes in packs of 50 pcs.

Type	Panel thickness (A) inches (mm)	Screw
SET0092	1 ¹ / ₈ " - 3 ¹ / ₁₆ (3 - 5)	M5 x 12
SET0093	3 ¹ / ₁₆ " - 23 ¹ / ₆₄ (5 - 9)	M5 x 16
SET0094	23 ¹ / ₆₄ " - 3 ¹ / ₁₆ (9 - 14)	M5 x 20
SET0095	9 ¹ / ₁₆ - 11 ¹ / ₁₆ (14 - 18)	M5 x 25

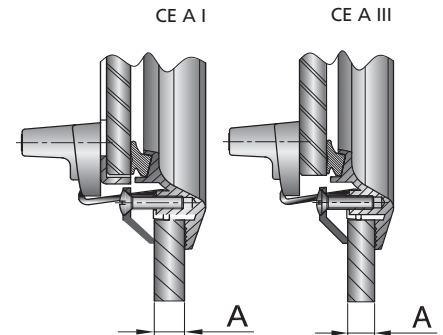

Portholes type PQ (All)

VETUS PQ portholes are made of stainless steel and include a counter flange. They have an 5¹/₁₆" (8 mm) thick acrylic 'smoke' coloured pane and come with a mosquito screen.



PQ

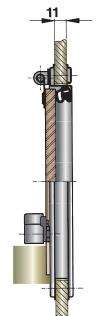
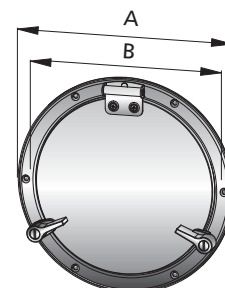

Type	External dimensions A inches (mm) Ø	Cut-out dimensions B inches (mm) Ø	Type mosquito screen
PQ51	6 ¹ / ₄ (158)	4 ¹⁵ / ₁₆ (126)	HORPQ51
PQ52	7 ¹ / ₄ (184)	5 ¹⁵ / ₁₆ (151)	HORPQ52
PQ53	8 ¹ / ₄ (210)	6 ¹⁵ / ₁₆ (176)	HORPQ53

PORTHOLES

Portholes - PA series (AIII)

The new low profile portholes

VETUS expands the selection of portholes with the low profile PA series. The ergonomic catches are easy to open and close and with the included interior trim you can have the same level of finish as our other products. On the outside the beautiful anodized aluminium frame gives the PA series a premium look and feel, with a slightly different finish compared to other portholes. The portholes come with a stylish black unframed opening pane. Fasteners are invisible from inside or outside and the windows are held open by friction type hinges.

The portholes are suitable for category 'A', Area III.

Available in sizes ranging from 12³/₈ x 7¹/₈ up to 25¹/₂ x 7⁵/₈" (315 x 180 up to 652 x 193 mm), there is bound to be one suitable for your vessel. The portholes can be fitted in a surface with a minimum thickness of 4 mm and a maximum thickness of 1" (25 mm) and are available in black or white powder coated finish on request. Other colors can be arranged on project base. PA portholes are supplied with a mosquito screen and an additional interior trim which can be cut to size to suit the panel thickness for that high-end finish.

Specifications

- Anodized aluminium frame
- Friction hinges for opening
- Ergonomic and precision engineered catches
- Easy to clean and maintenance-free design
- Suitable for category 'A', Area III
- With mosquito screen and interior trim



Type	Description	Cut-out dimensions inches (mm) Ø	External dimensions inches (mm) Ø	Radius (mm)
PA3016	Low profile aluminium porthole	11 ¹¹ / ₁₆ x 6 ³ / ₈ (297 x 162)	12 ³ / ₈ x 7 ¹ / ₈ (315 x 180)	2 ¹ / ₄ (57)
PA3517	Low profile aluminium porthole	13 ³ / ₄ x 6 ⁷ / ₈ (350 x 175)	14 ¹ / ₂ x 7 ⁵ / ₈ (368 x 193)	2 ¹ / ₄ (57)
PA4116	Low profile aluminium porthole	16 ¹ / ₁₆ x 6 ³ / ₈ (407 x 162)	16 ⁷ / ₈ x 7 ¹ / ₈ (425 x 180)	2 ¹ / ₄ (57)
PA4317	Low profile aluminium porthole	17 ¹ / ₈ x 6 ⁷ / ₈ (435 x 175)	17 ⁵ / ₈ x 7 ⁵ / ₈ (453 x 193)	2 ¹ / ₄ (57)
PA6317	Low profile aluminium porthole	2 x 7 ⁷ / ₈ (634 x 175)	25 ¹ / ₂ x 7 ⁵ / ₈ (652 x 193)	2 ¹ / ₄ (57)



ESCAPE AND VENTILATION HATCHES

Type PLANUS (All)

Stylish budget model

These hatches have a satin sheen anodised aluminium frame with a 3" (75 mm) corner radius and a 3/8" (10 mm) 'dark smoke' coloured acrylic lid. A friction hinge allows the hatches to remain open at any angle up to 180°. Type PLANUS is suitable for design category A, Area II.



PLA

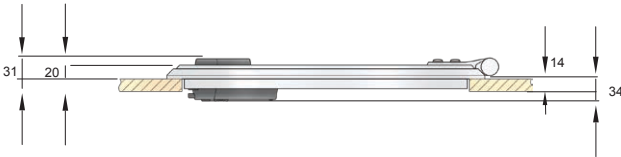

Maximum height (incl. dogs)

Escape hatches

Type	External dimensions A x B inches (mm)	Cut-out dimensions C x D inches (mm)	Number of handles
PLA50L	20 1/2 x 20 1/2 (521 x 521)	18 9/16 x 18 9/16 (471 x 471)	2
PLA45L	18 11/16 x 18 11/16 (474 x 474)	16 11/16 x 16 11/16 (424 x 424)	2

Ventilation hatches

Type	External dimensions A x B inches (mm)	Cut-out dimensions C x D inches (mm)	Number of handles
PLA34L	15 3/8 x 10 1/4 (390 x 260)	13 3/8 x 8 1/4 (340 x 210)	1
PLA30L	13 3/4 x 11 (350 x 280)	8 1/4 x 9 1/16 (300 x 230)	1
PLA23L	11 x 11 (280 x 280)	9 1/16 x 9 1/16 (230 x 230)	1

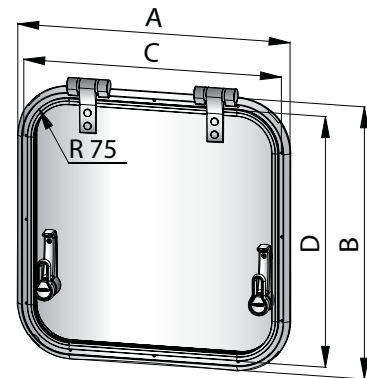

Deck hatches

Type	External dimensions A x B inches (mm)	Cut-out dimensions C x D inches (mm)	Number of handles
PLA40L	16 11/16 x 16 11/16 (424 x 424)	14 3/4 x 14 3/4 (374 x 374)	2
PLA32L	18 11/16 x 13 9/16 (474 x 344)	16 11/16 x 11 9/16 (424 x 294)	2

VETUS handles

Specifications

- The hatch can be opened from the inside or outside
- Can be locked or secured with an air gap for permanent ventilation
- An internal locking mechanism prevents opening from the outside when the boat is unattended
- The low external profiles ensures that ropes cannot get caught under the handles

Type	Description	Colour
HLLRBG	Hatch locks for all hatches	Black



OPEN



CLOSED

HLLRBG

ESCAPE AND VENTILATION HATCHES

Type FGH (All)

Stylish flush hatch

The FGH is specifically designed for new boats. The flush hatches are most suitable for new builds because the deck must be recessed to receive the hatch. After fitting, the hatches are completely recessed into the deck, leaving the deck smooth without visible lines.

Type FGH is available in four sizes and is made of 1/2" (12 mm) thick 'dark smoke' acrylic with a polished and anodised aluminium frame. Type FGH is suitable for design category A, Area II.



FGH

Escape hatches

Type	External dimensions A x B inches (mm)	Cut-out dimensions C x D inches (mm)	Number of handles
FGH6363	27 ⁹ / ₁₆ x 27 ⁹ / ₁₆ (700 x 700)	24 ¹¹ / ₁₆ x 24 ¹¹ / ₁₆ (627 x 627)	4
FGH5151	22 ¹³ / ₁₆ x 22 ¹³ / ₁₆ (580 x 580)	19 ¹⁵ / ₁₆ x 19 ¹⁵ / ₁₆ (507 x 507)	4
FGH4633	20 ³ / ₄ x 15 ⁵ / ₈ (527 x 397)	18 x 12 ⁷ / ₈ (457 x 327)	2
FGH5139	22 ¹¹ / ₁₆ x 18 ³ / ₁₆ (577 x 462)	19 ¹⁵ / ₁₆ x 15 ⁷ / ₁₆ (507 x 392)	2

Deck hatches

Type	External dimensions A x B inches (mm)	Cut-out dimensions C x D inches (mm)	Number of handles
FGH2626	20 ¹ / ₄ x 20 ¹ / ₄ (515 x 515)	17 ³ / ₈ x 17 ³ / ₈ (442 x 442)	1
FGH4444	13 x 13 (330 x 330)	10 ¹ / ₄ x 10 ¹ / ₄ (260 x 260)	3

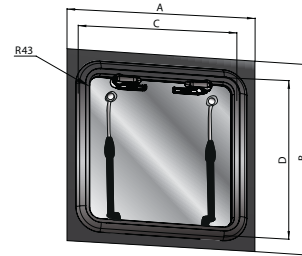

Hatch trims with mosquito screen

Neat finish and protection against insects

The complete range of hatches can be supplied with an adjustable depth trim complete with mosquito screen. These white synthetic trims are designed to cover the space between the hatch and the headlining inside the boat. The depth of the flange can be cut to size to suit the thickness of the deck. The integral and hinged mosquito screen can be easily removed to facilitate cleaning.

Type	Hatch	Type	Hatches	Type	Hatch	Type	Hatch
HCM23	PLA23L	HCM2626	MAG2626SL ALT2626SL FGH2626	HCMD420	ALTD420SL	HCM2020	LIB2032L
HCM30	PLA30L	HCM4242	MAG4242SL ALT4242SL	HCMD520	ALTD520SL	HCM3420	LIB3432L
HCM32	PLA32L	HCM4444	FGH4444	HCMR420	ALTR420SL	HCM4141	LIB4155L
HCM34	PLA34L	HCM4633	MAG4633SL ALT4633SL	HCMR520	ALTR520SL	HCM4532	LIB3255L
HCM40	PLA40L	HCM4747	MAG4747SL ALT4747SL			HCM5037	LIB3755L
HCM45	PLA45L	HCM5038	MAG5038SL ALT5038SL			HCM5050	LIB5055L
HCM50	PLA50L	HCM5151	MAG5151SL ALT5151SL FGH5151			HCM6262	LIB6255L
		HCM6363	MAG6363SL ALT6363SL FGH6363				

Deck thickness H inches (mm)

PLANUS	1 ⁹ / ₁₆ - 2 ⁷ / ₈ (40 - 73)
ALTUS	1 ³ / ₄ - 3 ³ / ₁₆ (44 - 81)
FGH	1 ³ / ₁₆ - 2 ⁵ / ₁₆ (30 - 59)
MAGNUS	1 ⁵ / ₁₆ - 2 ¹⁵ / ₁₆ (24 - 74)
LIBERO	9 ¹ / ₁₆ - 2 ¹ / ₂ (15 - 63)

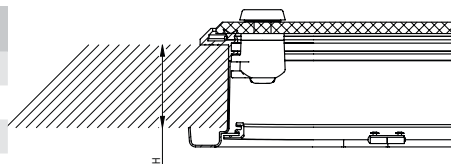

HCM



ESCAPE AND VENTILATION HATCHES

Type ALTUS (All)

Best midrange hatch in the business

ALTUS is made of a sturdy aluminium profile (height $1\frac{3}{16}$ " (21 mm)) with a satin sheen anodised frame and is suitable for design category A and appliance location area II. The acrylic has a thickness of $\frac{3}{8}$ " (10 mm) and is 'dark smoke' coloured. These hatches come with adjusters which are stylish and easy to operate, allowing the lid to be held open at almost any angle up to 90°. Type ALTUS can be fitted on deck and opened from the inside or outside. It has a ventilation position and can be locked completely watertight.



ALT

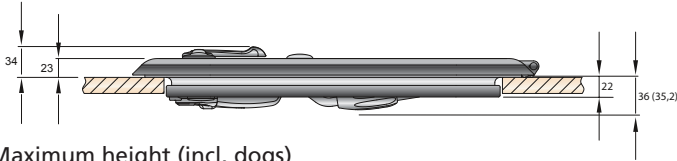

Maximum height (incl. dogs)

Escape hatches

Type	External dimensions A x B inches (mm)	Cut-out dimensions C x D inches (mm)	Model	Number of handles
ALT6363SL	$27\frac{5}{8} \times 27\frac{5}{8}$ (701 x 701)	$24\frac{11}{16} \times 24\frac{11}{16}$ (627 x 627)	1	2
ALT5151SL	$23\frac{1}{16} \times 23\frac{1}{16}$ (581 x 581)	$19\frac{15}{16} \times 19\frac{15}{16}$ (507 x 507)	1	2
ALT4747SL	$21\frac{7}{16} \times 21\frac{7}{16}$ (544 x 544)	$18\frac{1}{2} \times 18\frac{1}{2}$ (470 x 470)	1	2
ALTD520SL	$23\frac{5}{16} \times 20\frac{5}{8}$ (592 x 524)	$20\frac{3}{8} \times 17\frac{11}{16}$ (518 x 450)	2	2
ALTR520SL	$23\frac{5}{16}$ (592)	$20\frac{3}{8}$ (518)	3	2

Deck hatches

Type	External dimensions A x B inches (mm)	Cut-out dimensions C x D inches (mm)	Model	Number of handles
ALT4242SL	$19\frac{1}{2} \times 19\frac{1}{2}$ (495 x 495)	$16\frac{9}{16} \times 16\frac{9}{16}$ (421 x 421)	1	2
ALT5038SL	$22\frac{4}{16} \times 17\frac{3}{7}$ (581 x 451)	$9\frac{5}{16} \times 14\frac{13}{16}$ (507 x 377)	1	2
ALT4633SL	$20\frac{4}{16} \times 15\frac{13}{16}$ (531 x 401)	$18 \times 12\frac{7}{8}$ (457 x 327)	1	2
ALTR420SL	$19\frac{5}{16}$ (491)	$16\frac{7}{16}$ (417)	3	2

Ventilation hatches

Type	External dimensions A x B inches (mm)	Cut-out dimensions C x D inches (mm)	Model	Number of handles
ALT2626SL	$13\frac{1}{8} \times 13\frac{1}{8}$ (334 x 334)	$10\frac{1}{4} \times 10\frac{1}{4}$ (260 x 260)	1	1
ALTD420SL	$19\frac{5}{16} \times 12\frac{13}{16}$ (491 x 326)	$16\frac{7}{16} \times 9\frac{15}{16}$ (417 x 252)	2	2
ALA3502L	$16\frac{9}{16} \times 10\frac{7}{8}$ (421 x 276)	$13\frac{11}{16} \times 7\frac{15}{16}$ (347 x 202)	1	1

Trapezium hatch

Type	External dimensions A x B inches (mm)	Cut-out dimensions C x D inches (mm)	Model	Number of handles
ALA46TL	$21\frac{3}{8} \times 26\frac{13}{16} \times 17\frac{5}{8}$ (543 x 681 x 447)	$18\frac{1}{4} \times 23\frac{7}{8} \times 14\frac{7}{8}$ 464 x 607 x 378	4	2

Model 1

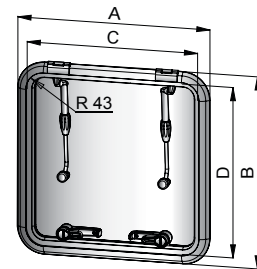

Model 2

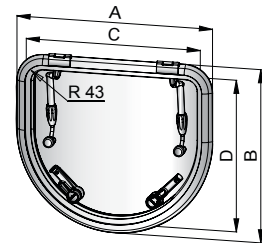

Model 3

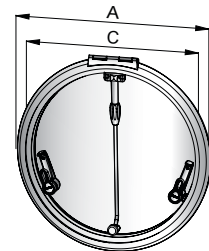

Model 4

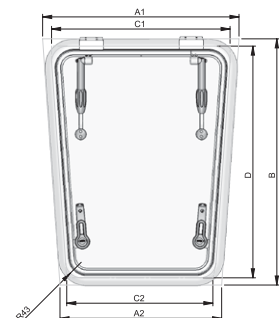

ESCAPE AND VENTILATION HATCHES

Type LIBERO (All)

Still going strong

These hatches have a hand polished and anodised aluminium frame with a 1 1/4" or 2 3/16" (32 or 55 mm) corner radius and a 3/8" (10 mm) 'dark smoke' coloured acrylic lid. The escape and deck hatches come with adjusters allowing the lid to be held open at almost any angle up to 90°. A special friction hinge allows the ventilation hatches to remain open at any angle up to 180°. Type LIBERO is suitable for design category A, Area II.



LIB

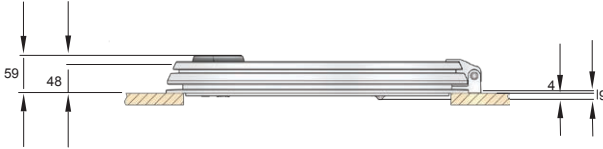

Maximum height (incl. dogs)

Escape hatches with adjusters up to 90°

Type	External dimensions A x B inches (mm)	Cut-out dimensions C x D inches (mm)	Cut-out radius R (mm)	Number of handles
LIB6232L	26 3/4 x 26 3/4 (680 x 680)	24 7/16 x 24 7/16 (620 x 620)	32	2
LIB6255L	26 3/4 x 26 3/4 (680 x 680)	24 7/16 x 24 7/16 (620 x 620)	55	2
LIB5032L	22 1/16 x 22 1/16 (560 x 560)	19 11/16 x 19 11/16 (500 x 500)	32	2
LIB5055L	22 1/16 x 22 1/16 (560 x 560)	19 11/16 x 19 11/16 (500 x 500)	55	2
LIB4155L	18 1/2 x 18 1/2 (470 x 470)	16 1/8 x 16 1/8 (410 x 410)	55	2

Deck hatches with adjusters up to 90°

Type	External dimensions A x B inches (mm)	Cut-out dimensions C x D inches (mm)	Cut-out radius R (mm)	Number of handles
LIB3732L	22 1/16 x 16 15/16 (560 x 430)	19 11/16 x 14 9/16 (500 x 370)	32	2
LIB3755L	22 1/16 x 16 15/16 (560 x 430)	19 11/16 x 14 9/16 (500 x 370)	55	2
LIB3232L	20 1/16 x 14 15/16 (510 x 380)	17 11/16 x 12 5/8 (450 x 320)	32	2
LIB3255L	20 1/16 x 14 15/16 (510 x 380)	17 11/16 x 12 5/8 (450 x 320)	55	2

Ventilation hatches with friction hinge up to 180°

Type	External dimensions A x B inches (mm)	Cut-out dimensions C x D inches (mm)	Cut-out radius R (mm)	Number of handles
LIB3432L	15 3/4 x 10 1/16 (400 x 255)	13 3/8 x 7 43/64 (340 x 195)	32	1
LIB2032L	10 1/4 x 10 1/4 (260 x 260)	7 7/8 x 7 7/8 (200 x 200)	32	1

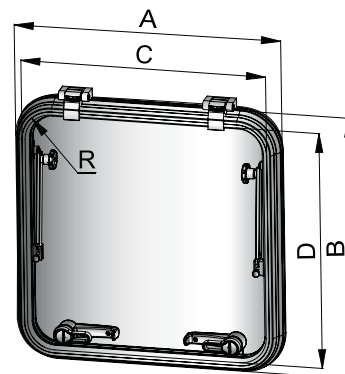

ESCAPE AND VENTILATION HATCHES

Type MAGNUS (A1)

Heavy duty ocean hatch

MAGNUS hatches have a satin sheen anodised frame profile with a $\frac{3}{8}$ " (10 mm) thick 'dark smoke' coloured acrylic and are designed for ocean use, design category A, Area I. These hatches can be opened from the inside or outside through 180° with almost no obstructions in the opening. They have a ventilation position and can be locked completely watertight. The cut-out sizes of this type match the market-based dimensions.

VETUS does not recommend the use of a Magnus hatch as a means of escape on multihulls below or near the waterline. The A1 hatch meets the Recreational Craft Directive (RCD2013/53/EU), however we cannot guarantee water tightness for this specific position. Please contact our glazing team for further information.



MAG

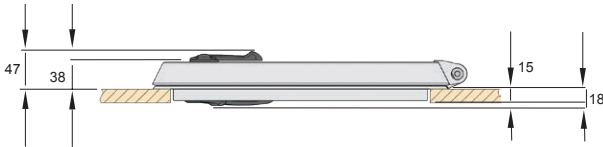

Maximum height (incl. dogs)

Escape hatches

Type	External dimensions A x B inches (mm)	Cut-out dimensions C x D inches (mm)	Number of handles
MAG6363SL	26 ³ / ₄ x 26 ³ / ₄ (679 x 679)	24 ¹¹ / ₁₆ x 24 ¹¹ / ₁₆ (627 x 627)	4
MAG5151SL	22 ³ / ₁₆ x 22 ³ / ₁₆ (559 x 559)	19 ¹⁵ / ₁₆ x 19 ¹⁵ / ₁₆ (507 x 507)	4
MAG4747SL	20 ⁹ / ₁₆ x 20 ⁹ / ₁₆ (522 x 522)	18 ¹ / ₂ x 18 ¹ / ₂ (470 x 470)	2

Deck hatches

Type	External dimensions A x B inches (mm)	Cut-out dimensions C x D inches (mm)	Number of handles
MAG4242SL	18 ¹¹ / ₁₆ x 18 ¹¹ / ₁₆ (473 x 473)	16 ⁹ / ₁₆ x 16 ⁹ / ₁₆ (421 x 421)	2
MAG5038SL	22 x 16 ¹ / ₄ (559 x 429)	19 ¹⁵ / ₁₆ x 14 ¹³ / ₁₆ (507 x 377)	2
MAG4633SL	20 ¹ / ₁₆ x 14 ¹⁵ / ₁₆ (509 x 379)	18 x 12 ⁷ / ₈ (457 x 327)	2

Ventilation hatches

Type	External dimensions A x B inches (mm)	Cut-out dimensions C x D inches (mm)	Number of handles
MAG2626SL	12 ⁵ / ₁₆ x 12 ⁵ / ₁₆ (312 x 312)	10 ¹ / ₄ x 10 ¹ / ₄ (260 x 260)	1
MAA3520L	15 ¹¹ / ₁₆ x 10 (399 x 254)	13 ¹¹ / ₁₆ x 7 ¹⁵ / ₁₆ (347 x 202)	2

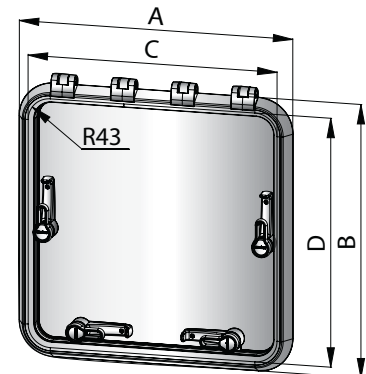

ESCAPE AND VENTILATION HATCHES

Hopper Windows

Fresh air without a catch

These new round windows with removable double glazed panes, are designed with canal boats in mind. These narrow boats are particularly cosy, with almost no room to spare. The round design of the hopper blends in perfectly with the trusted look of authentic canal boats.

Available in two diameters of 4¹⁵/₁₆" or 18¹/₁₆" (380 mm or 459 mm), our double glazed hopper porthole is easy to clean and provides an unimpeded view. Ergonomic clamps press the window firmly into the rubber seal, making it suitable for design area III locations.

With the clamps unlocked, the Hopper tilts back slightly to provide ventilation. From this position the whole pane can be removed if required. The polished and anodized aluminum frame is both stylish and maintenance free. It features a thermal break between the inner and outer frames, to prevent condensation forming on the inside. The frame is identical to the custom made boat windows to maintain uniformity throughout the boat.

Specifications

- Full double glazed porthole
- Polished and anodised aluminum frame with insulation bridge type thermal break principal
- Ergonomic and precision engineered catches
- Glass panels are easy to remove
- Sturdy aluminium tab at the top of the glass panel can be used to wall-mount it
- Easy to clean and maintenance-free design
- Suitable for design AIII locations



HOP



Type	Description	A Cut-out dimensions inches (mm)	B External dimensions inches (mm)
HOP380	Round 14 ¹⁵ / ₁₆ " (380 mm) double glass hopper with anodized aluminium frame and rubber seal	14 ¹⁵ / ₁₆ (380)	16 ¹ / ₈ (410)
HOP459	Round 18 ¹ / ₁₆ " (459 mm) double glass hopper with anodized aluminium frame and rubber seal	18 ¹ / ₁₆ (459)	19 ¹ / ₄ (489)

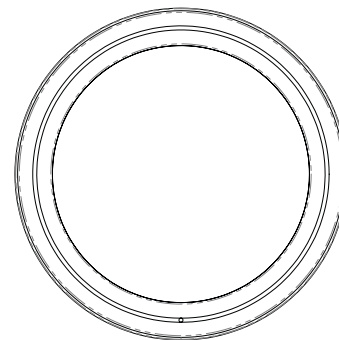
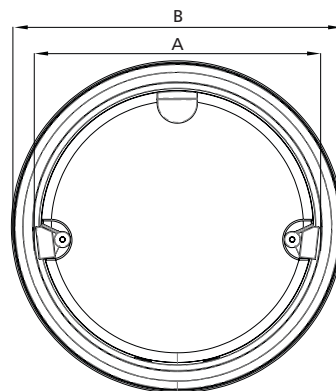
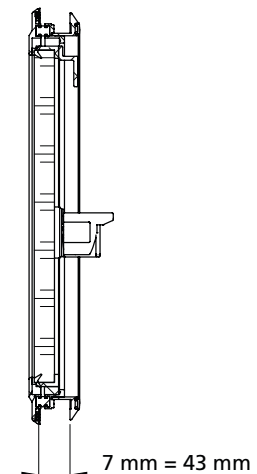

CUSTOM MADE BOAT GLAZING

MAREX

Marex is a brand long associated with high quality in custom made marine glazing products. The aluminium frames withstand a 1000-hour salt spray test without any observable damage. In addition, they are independently certified to comply with the Recreational Craft Directive and applicable ISO standards. This all ensures that your glazing will look like new for a long time.

To meet your needs, we offer three different window profiles: screw-on, comfort and exclusive. In addition we can provide fritted glass (frameless glass), windscreens, sliding hatches, cabin entries and doors. All products are made to measure.

The following frame finishes are available: anodised clear, powder coated in black (RAL 9005) or white (RAL 9010). Other colours are available on request.

Sliding and halfdrop type windows can be provided with a mosquito screen.



Exclusive double glass
Comfort single glass and
double glass
Screw-on single glass

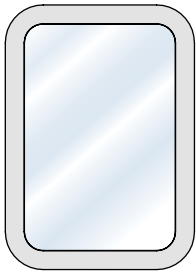

FIXED

Exclusive double glass
Comfort single glass and
double glass
Screw-on single glass (NEW)

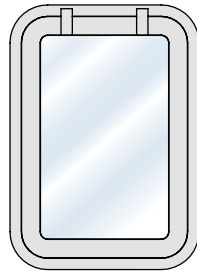

HINGED

Comfort single glass

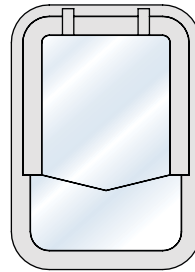

HALF HINGED

Comfort single glass
Screw-on single glass

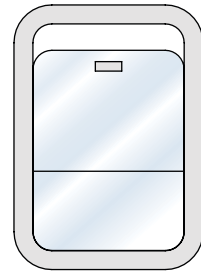

HALF DROP

Screw-on single glass
Comfort single glass

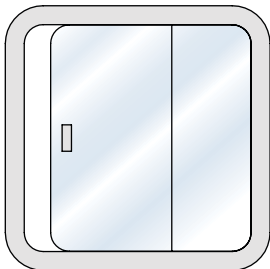

SLIDING

Screw-on single glass
Comfort single glass

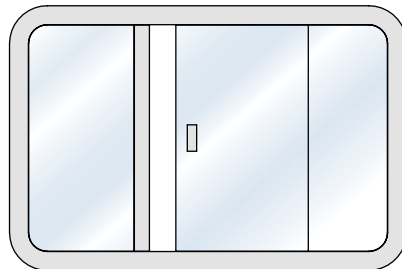

COMBINATION FIXED/SLIDING

Comfort single and double glass
Exclusive double glass

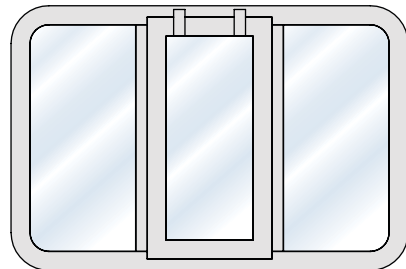

COMBINATION FIXED/HINGED

CUSTOM MADE BOAT GLAZING

MAREX



Screw-on range

Specifications

- Particularly suitable for wooden superstructures
- Suitable for all panel thicknesses
- Supplied with a black, white or grey strip to cover the screws
- With corner radii 2⁹/₁₆" , 3" , 3¹/₁₂" or 4¹/₈" (65, 75, 90 or 105 mm) or mitred corners
- Glass thickness: 1/4" (6 mm) or 5/16" (8 mm)

Cover strip

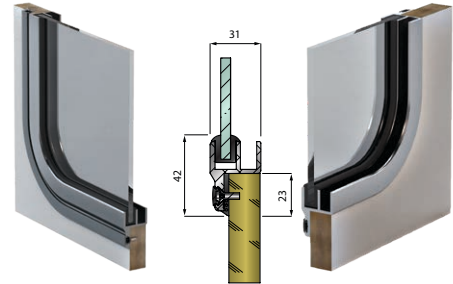

outside

Screw-on range

inside

Comfort range

Specifications

- Uses an aluminium clamp profile, fastened from inside by screws through the supplied aluminium counter flange (therefore no screws are visible from the outside of the boat)
- Suitable for panel thicknesses between 1/8" and 1⁵/₁₆" (3 and 33 mm) (fixed glass), 1/8" and 1⁷/₁₆" (3 and 37 mm) (sliding glass) or 1/8" and 1⁵/₈" (3 and 42 mm) (double glass)
- Supplied with a black, white or grey strip to cover the screws
- With corner radii 2⁹/₁₆" , 3" , 3¹/₁₂" or 4¹/₈" (65, 75, 90 or 105 mm) or mitred corners
- Available glass thicknesses: 1/4" , 5/16" and 3/8" (6, 8 and 10 mm for single glass or combined for double glass)

Cover strip

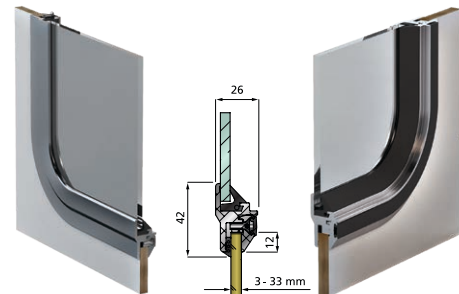

outside

Comfort range

inside

Exclusive range

Specifications

- Uses an aluminium clamp profile, fastened from inside by screws through the supplied aluminium counter flange (therefore no screws are visible from the outside of the boat)
- Suitable for panel thicknesses of 1/4" to 1¹/₁₆" (7 to 43 mm)
- Supplied with a black, white or grey strip to cover the screws and a seal for fitting
- To prevent condensation on the inside glass pane and window frame, the Exclusive range uses an (insulation bridge) insulated edge seal
- Available as fixed or fully hinged versions with double glass only
- With corner radii 3"* , 3¹/₁₂" or 4¹/₈" (75* , 90 or 105 mm) or mitred corners
- Available glass thicknesses 1/4" , 5/16" and 3/8" (6, 8 and 10 mm) can be combined for the double glass. The standard is two panes, each 1/4" (6 mm) thick

Cover strip

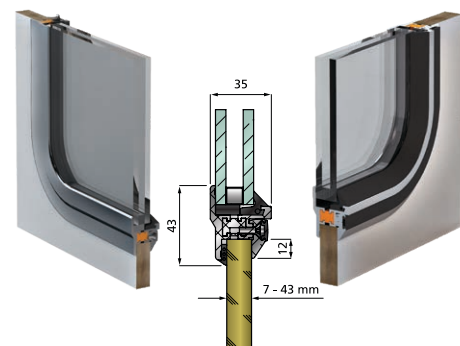

outside

Exclusive range

inside

*Except hinged windows



CUSTOM MADE BOAT GLAZING

MAREX

Cabin entries

Made to your dimensions

Both the hinged door and the top cover (hinged or sliding) are made to order to your required dimensions. The cabin entries can also be supplied without a door and the doors can be ordered without a hatch. All cabin entries are suitable for design category A, Area IV. Max. size 59¹/₁₆ x 39³/₈" (1500 x 1000 mm) per part (A or B x C).

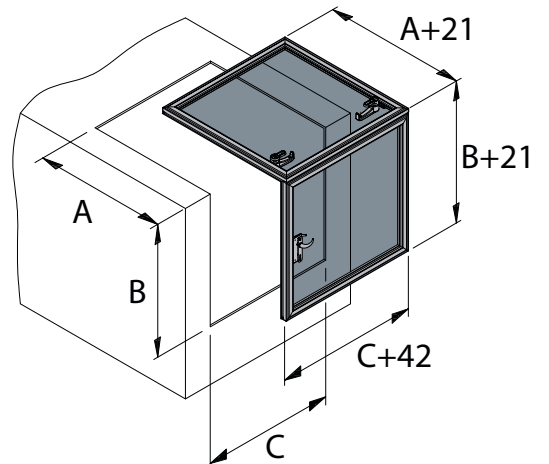
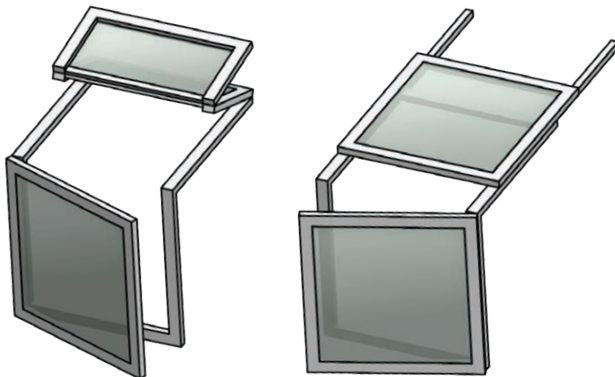
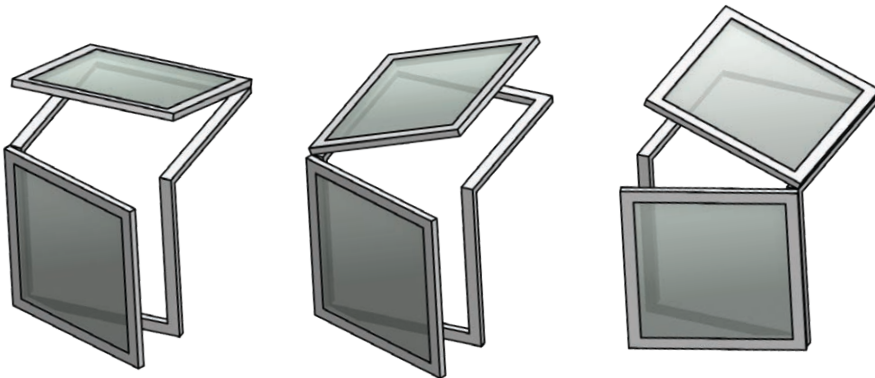

CUSTOM MADE BOAT GLAZING

MAREX

Sliding cabin entry

Easy sliding!

Equipped with bearing runners this single unit cabin entry opens and shuts very easily. In order to keep the sliding door in its open position an end-lock is mounted. Available with mitred corners, acrylic pane and angles from 90-180 degrees.

All cabin entries are suitable for design category A, Area IV.

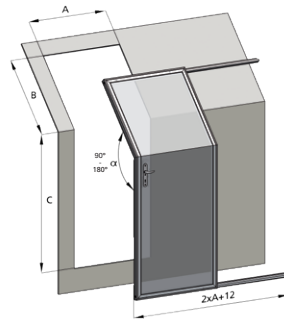

Hinged doors

For boating in heavy weather, these hinged doors are fitted with a double seal for protection against flooding. The door's upper section can be single or double glazed, or fitted with an opaque panel (tinted glass). Available with mitred or rounded corners.

All doors are suitable for design category A, Area IV.

Specifications

- Corner radius: $5\frac{1}{8}$ " (130 mm)
- Door thickness: $2\frac{5}{32}$ " (20 mm)
- Panel thickness: $\frac{1}{8}$ " - $1\frac{57}{64}$ " (3 - 48 mm)

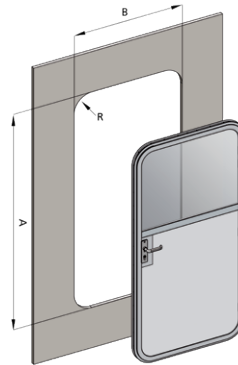

Type FBH - Fly Bridge Hatch

Slim and sleek design

To cover the opening between the deck and fly bridge we offer you: the FBH (Fly Bridge Hatch). The slim and sleek design of the FBH fits perfectly on modern type boats. This FBH can be tailor-made up to $24\frac{13}{16}$ " (630 mm) width and $51\frac{3}{16}$ " (1300 mm) long and features $\frac{1}{2}$ " (12 mm) dark smoke acrylic on a polished and anodised aluminium frame. With style and flair it merges flawlessly on the fly bridge of your vessel.

Specifications

- Privacy tinted fly bridge hatch
- $\frac{1}{2}$ " (12 mm) thick 'dark smoke' acrylic
- Polished and anodised high grade aluminium frame
- Ergonomic and precision engineered handles
- Hatches are available in both rectangular and square shapes
- Easy to clean and maintenance-free design
- Suitable for design category A, Area II



Type	External dimensions inches (mm)	Cut-out dimensions inches (mm)	Radius inches (mm)
FBH	up to $27\frac{11}{16}$ x $54\frac{1}{16}$ (703 x 1373)	up to $24\frac{13}{16}$ x $51\frac{3}{16}$ (630 x 1300)	$1\frac{11}{16}$ (43)

FBH



CUSTOM MADE BOAT GLAZING

MAREX

Windscreens

Choose your style

Our custom made windscreens are constructed from polished and anodised or powder-coated aluminium extrusions. The toughened glass can be supplied in the tints 'clear', green, grey, or bronze. The upper edges of the side screens can be made with a large radius curve. Below you see 2 installation possibilities.

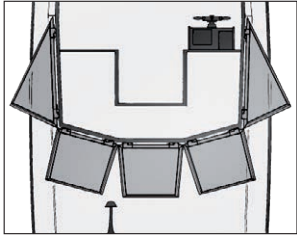

Installation option 1

There are two ways to secure the windscreen to the superstructure: either hinged (A) or fixed (B), see drawing.

For boats which often pass under low bridges, the windscreens can be hinged so each section can be lowered to the deck to reduce the craft's air draft.

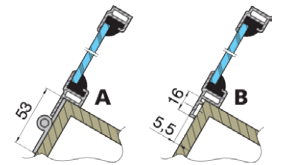

Installation option 2

The standard profile along the top edge of the windscreen is as shown in drawing A. If a spray hood is to be fitted, we can install the profile shown in drawing B, to which standard canvas fittings such as snaps or twist-locks can be attached.

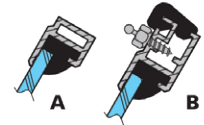

Fastening system for hinged windscreen

Flush Panoramic Sunroof

Ultimate benefits of a solid glass roof

Our panoramic sunroof is produced using the latest state-of-the-art techniques, components and materials, operating both silently and smoothly. You can enjoy the sun and the ocean breeze by opening the panoramic roof (measuring 78³/₄ x 84⁵/₈" - 2000 x 2150 mm) or keep the weather out by simply closing it.

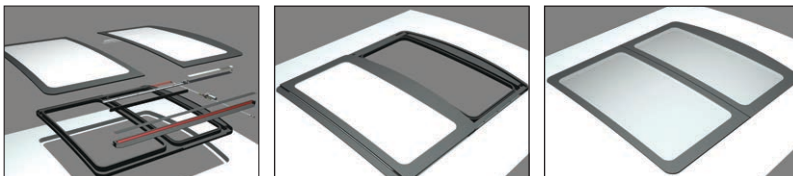

Model	Flush Panoramic Sunroof
Outside dimensions	78 ³ / ₄ x 84 ⁵ / ₈ " (2000 x 2150 mm)
Roof radius	39.3 ft (12 m)
Weight (excl. glass)	187.3 lbs (85 kg)
Weight (incl. glass)	385.8 lbs (175 kg)
Voltage	230 V / 260 W

WINDSCREEN WIPER, ARMS AND BLADES

Windscreen wiper motor type RW and DIN

Ideal wiping for almost any window shape and size

These high quality marine windscreen wipers feature a powerful but quiet 2 speed electric motor and a separate worm gear transmission. The wiping angle can be adjusted to 8 different settings. Type RW has a parallel push fit connection. Type DIN has a tapered and knurled connection with a securing nut providing a stronger connection between the wiper arm and the motor drive shaft resulting in a longer life span for both parts. Both types are self-parking and meet the EMC requirements.

Specifications

- Available for 12 or 24 Volt D.C. supply
- Output 30 Watt
- Suitable for panel thickness from 1/8" (3 mm) to 1/2" (13 mm) (short shaft) or 1/8" (3 mm) to 1 1/2" (38 mm) 3 to 38 mm (long shaft)
- Type RW with straight knurled stainless steel shaft end of Ø 17/32" (13,5 mm), 72 teeth
- Type DIN with tapered and knurled stainless steel shaft according to DIN 72783
- Optional: screen washer kit, 3-position switch, protective synthetic cover, control panel



RW



DIN

Type	Specifications
RW01A	Wiper motor 12 V, 51 mm spindle with parallel end
RW02A	Wiper motor 24 V, 51 mm spindle with parallel end
RW08A	Wiper motor 12 V, 25 mm spindle with parallel end
RW09A	Wiper motor 24 V, 25 mm spindle with parallel end
DIN1250	Wiper motor 12 V, 51 mm spindle with DIN tapered end
DIN2450	Wiper motor 24 V, 51 mm spindle with DIN tapered end
DIN1225	Wiper motor 12 V, 25 mm spindle with DIN tapered end
DIN2425	Wiper motor 24 V, 25 mm spindle with DIN tapered end

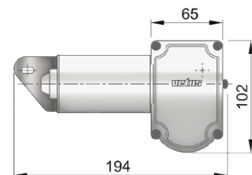
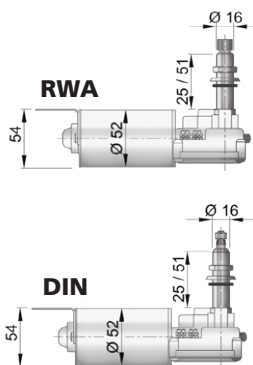

Plastic cover for wiper type RW and DIN

By installing the plastic cover, you will reduce the indicated panel thickness by 1/8" (3 mm), complete with bottom plate.

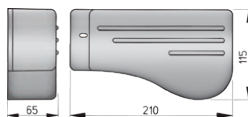

RWCG



How to choose wiper arms and blades (single arm)

When ordering, the voltage, shaft length and shaft end type must be stated. The table below shows the required wiping angle for almost any window. Wiper arms and blades should be ordered separately (see page 281).

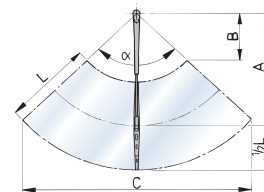

Single arm adjustable from 15 5/16 to 18 1/8 inch

α°	L: 12"		L: 16 1/8"		L: 20"		
	Min.	Max.	Min.	Max.	Min.	Max.	
40	A:	15 5/16	18 1/8	15 5/16	18 1/8	15 5/16	18 1/8
	B:	9	12 1/16	7 1/16	10 1/16	5 1/8	8 3/8
	C:	14 3/4	17 1/16	16 1/8	18 1/16	17 1/2	19 3/16
50	A:	15 5/16	18 1/8	15 5/16	18 1/8	15 5/16	18 1/8
	B:	8 11/16	11 1/4	6 1/4	9 1/16	5 1/8	8 1/8
	C:	18 1/4	21 1/16	19 1/8	22 1/16	21 5/8	24 1/16
60	A:	15 5/16	18 1/8	15 5/16	18 1/8	15 5/16	18 1/8
	B:	8 1/4	11 1/16	6 1/2	9 1/16	4 13/16	7 3/4
	C:	21 1/16	24 1/16	23 3/8	27	25 5/16	28 5/16
70	A:	15 5/16	18 1/8	15 5/16	18 1/8	15 5/16	18 1/8
	B:	7 13/16	10 1/16	6 1/8	8 1/8	4 9/16	186
	C:	24 3/4	28 3/8	27 1/16	31	29 5/16	843
80	A:	15 5/16	18 1/8	15 5/16	18 1/8	15 5/16	17 3/16
	B:	7 5/16	9 13/16	5 1/4	8 1/4	4 1/4	5 1/2
	C:	27 1/16	32 1/16	30 3/4	34 3/4	32 13/16	34 15/16
90	A:	15 5/16	18 1/8	15 5/16	18 1/8		
	B:	6 1/4	9 1/8	5 1/4	7 1/16		
	C:	30 1/2	35 1/4	33 1/8	38 1/8		
100	A:	15 5/16	18 1/8	15 5/16	17 1/16		
	B:	6 1/8	8 1/16	4 13/16	5 1/8		
	C:	33 1/16	38 1/4	36 3/16	38 5/16		
110	A:	15 5/16	18 1/8	15 5/16			
	B:	5 1/2	7 3/8	4 1/16			
	C:	35 5/16	40 7/8	38 11/16			

Single arm adjustable from 18 5/8 to 22 inch

α°	L: 12"		L: 16 1/8"		L: 20"		
	Min.	Max.	Min.	Max.	Min.	Max.	
40	A:	18 5/8	22	18 5/8	22	18 5/8	22
	B:	11 1/16	15 1/16	9 1/16	13 1/16	8 1/4	11 1/16
	C:	16 1/8	19 1/16	18 1/4	20 1/16	19 5/16	21 1/8
50	A:	18 5/8	22	18 5/8	22	18 5/8	22
	B:	11 1/16	14 1/2	9 1/16	12 1/8	7 1/16	10 7/8
	C:	20 3/16	23 1/16	22 3/16	25 1/16	24 3/16	27 1/16
60	A:	18 5/8	22	18 5/8	22	18 5/8	22
	B:	10 13/16	13 3/8	9 1/8	12 1/16	7 1/2	10 5/8
	C:	24 1/8	28 1/16	26 1/16	30 1/16	28 5/8	32
70	A:	18 5/8	22	18 5/8	22	18 5/8	19 11/16
	B:	10 3/8	13 1/8	8 1/16	11 1/16	7 1/16	7 1/16
	C:	28 1/4	32 1/8	30 3/8	34 1/2	32 13/16	34 1/16
80	A:	18 5/8	22	18 5/8	21 1/16		
	B:	9 11/16	12 1/4	8 1/8	10 1/8		
	C:	31 3/8	36	34 1/16	37 1/16		
90	A:	18 5/8	22	18 5/8	19		
	B:	8 9/16	11 3/16	7 1/2	7 1/16		
	C:	34 1/16	39 7/8	37 1/4	38 1/4		
100	A:	18 5/8	22				
	B:	8 1/8	10 1/4				
	C:	37 1/16	42 1/16				
110	A:	18 5/8	20 7/8				
	B:	7 1/4	8 3/8				
	C:	40 7/8	44				

Single arm adjustable from 11 to 14 7/16 inch

α°	L: 12"		L: 16 1/8"		L: 20"		
	Min.	Max.	Min.	Max.	Min.	Max.	
40	A:	11	14 7/16	11	14 7/16	11	14 7/16
	B:	4 3/4	7 13/16	2 3/4	5 13/16	1 15/16	4 1/8
	C:	11 5/8	14	13 1/16	15 1/8	14 3/8	16 1/16
50	A:	11	14 7/16	11	14 7/16	11	14 7/16
	B:	4 9/16	7 5/8	2 11/16	5 1/4	1 15/16	4
	C:	14 7/16	17 1/4	16 1/8	19	17 1/4	20 3/8
60	A:	11	14 7/16	11	14 7/16	11	14 7/16
	B:	4 9/16	7 5/8	2 9/16	5 1/2	1 7/8	3 13/16
	C:	17 1/16	20 1/16	19 1/8	22 1/2	21	24 1/16
70	A:	11	14 7/16	11	14 7/16	11	14 7/16
	B:	4 1/4	6 7/8	2 1/8	5 1/8	1 13/16	3 3/8
	C:	19 1/2	23 1/16	21 1/8	25 13/16	24 1/8	28
80	A:	11	14 7/16	11	14 7/16	11	14 7/16
	B:	3 3/8	6 1/8	2 1/4	4 13/16	1 13/16	3 3/8
	C:	21 1/8	26 1/4	24 1/16	28 1/8	27	31 3/8
90	A:	11	14 7/16	11	14 7/16	11	14 7/16
	B:	3 7/8	5 9/16	2 1/16	4 1/2	1 1/8	3 1/8
	C:	24 1/8	28 1/8	27	31 13/16	29 1/4	34 1/2
100	A:	11	14 7/16	11	14 7/16	11	13 3/4
	B:	3 1/4	5 5/8	1 7/8	4 1/8	1 13/16	2 7/16
	C:	26 1/8	31 1/4	29 1/4	34 1/16	32 1/16	36 1/16
110	A:	11	14 7/16	11	14 7/16	11	12 1/2
	B:	2 7/8	4 3/16	1 11/16	3 3/8	1 1/16	1 7/16
	C:	27 13/16	33 1/16	31 1/16	36 13/16	34 1/16	36 7/8

WINDSCREEN WIPERS

Wiper arm types RWA and DINP

Adjustable single / dual wiper arms

These wiper arms are made of high-gloss polished stainless steel and black components of top-grade synthetic materials. Both types are available in several sizes (see below). All dual wiper arms are supplied with an idle spindle and connection set.

Single wiper

- Sizes: **S** from 11" to 14⁷/₁₆" (280 to 366 mm) / **L** from 15⁹/₁₆" to 18¹⁵/₁₆" (395 to 481 mm) / **X** from 18⁵/₈" to 22" (473 to 559 mm)
- Spade connector 9/12" x 3/32" (7,2 x 2,5 mm)

Dual wiper

- Sizes: **D** from 12¹/₈" to 15¹/₂" (308 to 393 mm) / **DX** from 15³/₁₆" to 18⁹/₁₆" (386 to 471 mm)
- Spindle centres 1³/₄" (45 mm)
- Spade connector 9/12" x 3/32" (7,2 x 2,5 mm)

Type	Arm	Length inches (mm)	Motor type
RWAS	Black single arm	11 - 14 ⁷ / ₁₆ (280 - 366)	RW
RWAL	Black single arm	15 ⁹ / ₁₆ - 18 ¹⁵ / ₁₆ (395 - 481)	RW
RWAX	Black single arm	18 ⁵ / ₈ - 22 (473 - 559)	RW
RWAD	Black dual arm set	12 ¹ / ₈ - 15 ¹ / ₂ (308 - 393)	RW
RWADX	Black dual arm set	15 ³ / ₁₆ - 18 ⁹ / ₁₆ (386 - 471)	RW
DINPS	Black single arm	11 - 14 ⁷ / ₁₆ (280 - 366)	DIN
DINPL	Black single arm	15 ⁹ / ₁₆ - 18 ¹⁵ / ₁₆ (395 - 481)	DIN
DINPX	Black single arm	18 ⁵ / ₈ - 22 (473 - 559)	DIN
DINPD	Black dual arm set	12 ¹ / ₈ - 15 ¹ / ₂ (308 - 393)	DIN
DINPDX	Black dual arm set	15 ³ / ₁₆ - 18 ⁹ / ₁₆ (386 - 471)	DIN



RWA Without taper

DINP With DIN taper

Wiper blade type WBB and WBS

Fit almost all makes and types of wiper arms with a 9/12" x 3/32" (7,2 x 2,5 mm) bayonet

The metal parts of these blades are made of AISI 316 stainless steel, either high-gloss polished or black coated. These blades will fit almost all makes and types of wiper arms with a 9/12" x 3/32" (7,2 x 2,5 mm) bayonet. They are available in lengths of 12", 16" or 20" (305, 410 or 508 mm).

Type	Wiper blade	Finish	Length inches (mm)
WBB30	Stainless steel	Coated black	12 (305)
WBB41	Stainless steel	Coated black	16 (410)
WBB51	Stainless steel	Coated black	20 (508)
WBS30	Stainless steel	Gloss polished	12 (305)
WBS41	Stainless steel	Gloss polished	20 (410)
WBS51	Stainless steel	Gloss polished	16 (508)



WBB

WBS

Wiper arm type SSA and DINS

Strong, durable and stylish!

These arms are entirely made of strong and durable high-gloss polished stainless steel (AISI 316). In combination with VETUS polished wiper blades they will enhance the appearance of any boat!

Type	Arm	Length inches (mm)	Motor type
SSAS	Single arm, stainless steel	11 - 14 ⁷ / ₁₆ (280 - 366)	RW
SSAL	Single arm, stainless steel	15 ⁹ / ₁₆ - 18 ¹⁵ / ₁₆ (395 - 481)	RW
SSAX	Single arm, stainless steel	18 ⁵ / ₈ - 22" (473 - 559)	RW
SSAD	Dual arm set, stainless steel	12 ¹ / ₈ - 15 ¹ / ₂ (308 - 393)	RW
SSADX	Dual arm set, stainless steel	15 ³ / ₁₆ - 18 ⁹ / ₁₆ (386 - 471)	RW
DINSS	Single arm, stainless steel	11 - 14 ⁷ / ₁₆ (280 - 366)	DIN
DINSL	Single arm, stainless steel	15 ⁹ / ₁₆ - 18 ¹⁵ / ₁₆ (395 - 481)	DIN
DINSX	Single arm, stainless steel	18 ⁵ / ₈ - 22" (473 - 559)	DIN
DINSD	Dual arm set, stainless steel	12 ¹ / ₈ - 15 ¹ / ₂ (308 - 393)	DIN
DINSDX	Dual arm set, stainless steel	15 ³ / ₁₆ - 18 ⁹ / ₁₆ (386 - 471)	DIN



SSA Without taper

DINS With DIN taper



WINDSCREEN WIPERS

Wiper type ORW12SET

Supplied as a complete set comprising motor, arm and blade

The arm length is adjustable from 11" to 14⁷/₁₆" (280 to 366 mm). The motor is self-parking, has a single speed and a wiping angle of 80° or 110°. The wiper blade is made of black synthetic and fits also other makes of wiper arms with a 9/12" x 3/32" (7,2 x 2,5 mm) bayonet. Type ORW12SET meets all the EMC requirements.

Specifications

- Available for 12 Volt D.C.
- Max. current consumption 2A
- Max. panel thickness 1³/₁₆" (20 mm)
- Blade length 12" (305 mm)

Type	Specifications
ORW12SET	Wiper motor set, incl. wiper motor, arm and blade (12V)
WBB30	Wiper blade, stainless steel, coated black

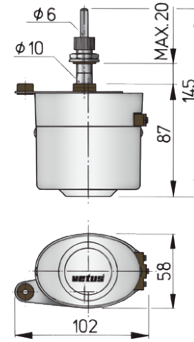

ORW12SET

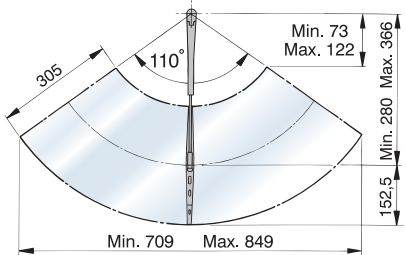

Wiping angle:
standard 110°,
adjustable to 80°

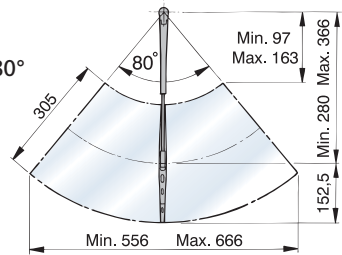

Clear view screens type SLR

Completely clear vision at all times

The centrifugal force caused by the rotating toughened glass, which reaches its maximum revolutions per minute within 25 seconds, instantly clears the screen from rain, snow and spray. Even dirt and salt will not cause any smears. Type SLR is available in 2 sizes and meets all the EMC requirements.

Specifications

- Type 300 (screen Ø 11¹³/₁₆" (300 mm)) / type 350 (screen Ø 13³/₄" (350 mm))
- Both types available for 12 or 24 Volt D.C.
- Max. current consumption 2,7A (12 Volt) / 1,4A (24 Volt)

Type	Specifications
SLR30012	Clear view screen Ø 11 ¹³ / ₁₆ " (300 mm) o.a. 12 Volt
SLR30024	Clear view screen Ø 11 ¹³ / ₁₆ " (300 mm) o.a. 24 Volt
SLR35012	Clear view screen Ø 13 ³ / ₄ " (350 mm) o.a. 12 Volt
SLR35024	Clear view screen Ø 13 ³ / ₄ " (350 mm) o.a. 24 Volt



SLR

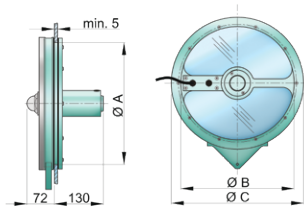

Type	Dimensions		
	Cut-out Ø A	Ø B	Ø C
Type 300	10 ¹³ / ₁₆ " (275)	9 ¹³ / ₁₆ " (250)	11 ¹³ / ₁₆ " (300)
Type 350	12 ¹³ / ₁₆ " (326)	11 ¹³ / ₁₆ " (300)	13 ³ / ₄ " (350)

WINDSCREEN WIPERS HEAVY DUTY

Windscreen wiper type HDM

This quiet windscreen wiper is interchangeable with previous models HDM (A, B and C). It has a thermal cut-out which will protect the electric motor in case of excessive operating temperature. Type HDM is self-parking on either side, has 2 speeds and is available with 2 different shaft lengths. The wiping angle is fully adjustable between 62° and 92°. To determine the optimum wiping surface of each specific window, please see tables below for detailed specifications. All visible parts of the mechanism are made of stainless steel and meet the EMC requirements.

Specifications

- Available for 12 or 24 Volt D.C.
- Power 75 Watt
- Weight (without arm and blade) 5 1/2 lbs (2,5 kg)

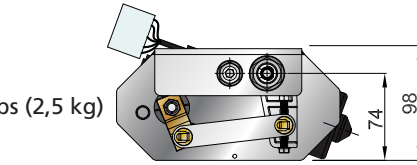
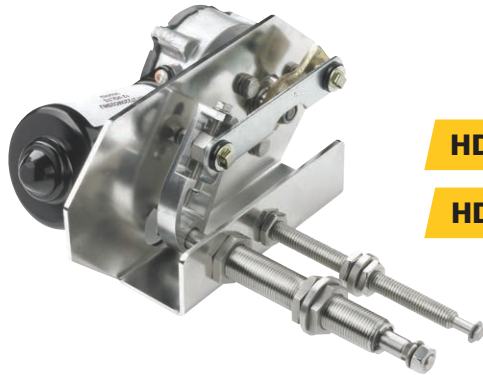

- HDM..DS** Short shafts
- HDM..DL** Long shafts

HDMCOVER

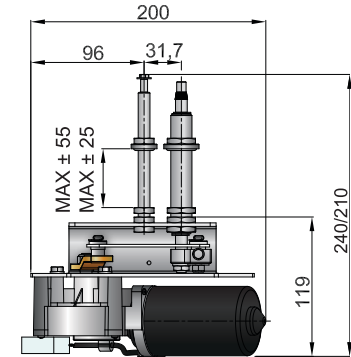

Type	Specifications
HDM12DL	Heavy duty wiper motor, long shaft, adjustable wipe angle, 12V
HDM24DL	Heavy duty wiper motor, long shaft, adjustable wipe angle, 24V
HDM12DS	Heavy duty wiper motor, short shaft, adjustable wipe angle, 12V
HDM24DS	Heavy duty wiper motor, short shaft, adjustable wipe angle, 24V
HDMCOVER	Plastic cover for HDM motors

Type	Description	Length (mm)
Wiper arms		
SHDA400	Stainless steel AISI 316 dual wiper arm	15 ²⁵ / ₃₂ - 19 ⁹ / ₆₄ (401 - 486)
SHDA500	Stainless steel AISI 316 dual wiper arm	20 - 23 ¹¹ / ₃₂ (508 - 593)
SHDA760	Stainless steel AISI 316 dual wiper arm	24 ²¹ / ₃₂ - 30 (677 - 762)

Wiped areas of heavy duty windscreen wiper assemblies with HDM motors

SHDA760

α°		L: 18 1/8"		L: 22 1/16"		L: 26"	
		Min.	Max.	Min.	Max.	Min.	Max.
62	A	26 3/8"	30"	26 3/8"	30"	26 3/8"	30"
	B	13 3/4"	16 3/8"	11 13/16"	14 1/16"	9 13/16"	12 11/16"
	C	27 1/16"	30 3/8"	27 1/16"	30 3/8"	27 1/16"	30 3/8"
	D	35 11/16"	39 1/16"	37 11/16"	41"	39 1/16"	43"
92	A	26 3/8"	30"	26 3/8"	30"	26 3/8"	30"
	B	9 3/16"	11 3/4"	7 1/2"	9 13/16"	5 1/2"	7 13/16"
	C	38 3/8"	43 3/8"	38 3/8"	43 3/8"	38 3/8"	43 3/8"
	D	35 11/16"	39 1/16"	37 11/16"	41"	39 1/16"	43"

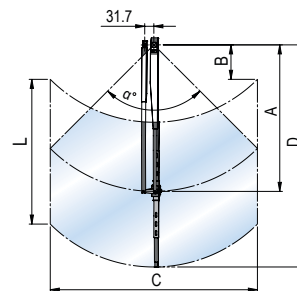

SHDA500

α°		L: 18 1/8"		L: 22 1/16"		L: 26"	
		Min.	Max.	Min.	Max.	Min.	Max.
62	A	20"	23 3/8"	20"	23 3/8"	20"	23 3/8"
	B	8 1/16"	10 1/16"	6 1/8"	9"	4 1/8"	7"
	C	20 3/16"	24 1/16"	20 3/16"	24 1/16"	20 3/16"	24 1/16"
	D	29 1/16"	32 3/8"	31"	34 3/8"	33"	36 3/16"
92	A	20"	23 3/8"	20"	23 3/8"	20"	23 3/8"
	B	4 13/16"	7 1/16"	2 7/8"	5 1/16"	1 3/4"	3 1/4"
	C	28 1/4"	33 3/16"	28 1/4"	33 3/16"	28 1/4"	33 3/16"
	D	29 1/16"	32 3/8"	31"	34 3/8"	33"	36 3/16"

SHDA400

α°		L: 18 1/8"		L: 22 1/16"		L: 26"	
		Min.	Max.	Min.	Max.	Min.	Max.
62	A	15 13/16"	19 1/8"	15 13/16"	19 1/8"	15 13/16"	19 1/8"
	B	4 1/4"	7 1/4"	2 1/4"	5 1/8"	1 9/16"	3 7/16"
	C	16 1/4"	19 1/4"	16 1/4"	19 1/4"	16 1/4"	19 1/4"
	D	24 13/16"	28 3/16"	26 13/16"	30 3/16"	28 3/16"	32 1/8"
92	A	15 13/16"	19 1/8"	15 13/16"	19 1/8"	15 13/16"	19 1/8"
	B	1 13/16"	4 1/16"	-13/16"	2 3/16"	-2"	1/16"
	C	22 11/16"	27 1/2"	22 11/16"	27 1/2"	22 11/16"	27 1/2"
	D	24 13/16"	28 3/16"	26 13/16"	30 3/16"	28 3/16"	32 1/8"



SHDA..

WINDSCREEN WIPERS

Wiper arms and blades type WB and SHDA

Heavy duty stainless steel wiper arms and blades for wiper motor HDMD

These heavy duty wiper arms and blades are made from AISI 316 stainless steel, ensuring a long and trouble free life. They are available in a high gloss polished finish or coated black.

Type	Description	Length inches (mm)
Wiper blades		
WBS46H	Wiper blade, made of high-gloss polished stainless steel 316	18 ⁷ / ₆₄ (460)
WBS56H	Wiper blade, made of high-gloss polished stainless steel 316	22 ³ / ₆₄ (560)
WBS66H	Wiper blade, made of high-gloss polished stainless steel 316	26 (660)
WBB46H	Wiper blade, made of stainless steel 316, coated black	18 ⁷ / ₆₄ (460)
WBB56H	Wiper blade, made of stainless steel 316, coated black	22 ³ / ₆₄ (560)
WBB66H	Wiper blade, made of stainless steel 316, coated black	26 (660)

WBS..H

WBB..H



ACCESSORIES

Complete screen washer kit type WWFR

Always a clear view

Type WWFR includes a reservoir with integral pump, tubing with non-return valve, rotary switch and a unique long double spray nozzle to reach over thick windscreen frame profiles and wiper blades. An extension kit (code HDSXTB) consisting of a second double spray nozzle, additional tubing and a T-piece is available and recommended to maintain sufficient flow and pressure.

Specifications

- Available in 12 or 24 Volt D.C.
- Max. current consumption 1,8A (12 Volt) / 0,9A (24 Volt)
- Tubing length 10" (3 metre)
- Reservoir capacity 51 oz (1.5 litres)
- Pump output 0.30 oz/min (0.88 litres/min)

WWFR..



Type	Description	Voltage (V)	Current (A)	Capacity
WWFR12	Screen washer kit complete, including resevoir (1,5L)	12	1,8	0.30 oz/min
WWFR24	Screen washer kit complete, including resevoir (1,5L)	24	0,9	0.30 oz/min
HDSXTB	Extension screen washer kit for additional windscreen			

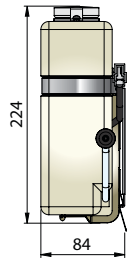

Three-position switch

For two-speed wiper motors

Available as rotary or rocker type switch. Suitable for two-speed wiper motors RWS, DIN and HDM. Not suitable for type ORW.

Type	Max. panel thickness inches (mm)	Max. switch current (A)
HDMSW	9/32" (7)	20
HDMSW2	1/4" (6)	20



HDMSW



HDMSW2

ACCESSORIES

Screen washer

Suitable for all VETUS wiper types

This screen washer is fed by a pressurised, potable water system. The screen washer comes with a hose, solenoid valve (12 or 24 Volt D.C.) and switch, hose pillars, spray nozzles and skin fittings and is easy to install.

Type	Description	Voltage (V)
HDS12B	Screen washer kit	12
HDS24B	Screen washer kit	24
HDSXTB	Extension screen washer kit for additional windscreen	

HDS



Type WPANEL in combination with rain sensor type MARBO

Completely pre-wired motor wipe panel

Type WPANEL can control up to 5 wiper motors to run synchronously at high or low speed. Each wiper motor is individually switched, so you can select which wipers are operational. They also feature a combination switch for screen wash/wipe activation, speed selection and interval wipe delay. The wiper motors to be connected must have a 2 speed motor and an automatic parking position. It is optional to connect up to 3 MARBO rain sensors to the control unit. The rain sensor function can be activated by the supplied switch panel and can activate all 5 wipers simultaneously.

Type WPANEL is supplied with

- 1 control unit with electronic overload protection (can be DIN rail mounted)
- 5 wiper motor switches
- 1 combined switch for wash/wipe and speed selection
- 1 mounting plate with room for 6 switches and 2 blind plates

Specifications

- Available for 12 or 24 Volt D.C. supply
- Power consumption in stand-by mode approx. 10 mA
- Maximum power per wiper motor 120 W
- Internal fuses 10 A each wiper motor, 5 A for screen wash pump or solenoid valve
- Dimensions control panel 1¹⁵/₁₆" x 1¹⁵/₁₆" x 1¹⁵/₃₂" (49 x 24 x 37,5 mm), control unit 6¹/₄" x 3⁹/₁₆" x 2³/₁₆" (159 x 90 x 58 mm)



WPANEL



Automatic rain-sensor for wiper activation



MARBO



MARBO2

Type	Specifications
MARBO	Rain sensor incl. switch, 12/24 Volt
MARBO2	Additional rain sensor, 12/24 Volt
WPANEL	Windscreen wiper control panel for up to 5 wipers, 12/24 Volt, incl. switches



ACCESSORIES

Type RWPANEL

Control panel for up to three windscreen wipers

This panel will control up to 3 switched windscreen wipers synchronously and also activate a screen wash system. The wipers can be set to run at high or low speed at 1 of 5 interval wipes and will self-park when they are switched off. It is possible to connect up to 3 rain sensors (type MARBO2) for automatic operation of the wipers.

Specifications

- Panel is suitable for 12 or 24 Volt D.C. supply
- Dimensions control panel 3³/₈" x 3³/₈" (85 x 85 mm), control unit 6¹/₄" x 3³/₁₆" x 2³/₁₆" (159 x 90 x 58 mm)
- Built-in depth 1⁹/₁₆" (40 mm)



Type	Specifications
RWPANEL2	Windscreen wiper control panel for up to 3 wipers, 12/24 Volt, incl. control panel

RWPANEL2

ENGINE HATCH LIFTER

Type HL...A/B

Opening a heavy hatch was never this easy

This electro-hydraulic 'stand-alone' lifting system makes opening a heavy hatch or lowering a mast or radar arch an easy affair. The standard system consists of a seawater resistant aluminium cylinder with a stainless steel (AISI 316) rod, an electro-hydraulic pump, a waterproof control panel, 40 ft (12 metres) of hydraulic piping and all required hose connectors. VETUS electro-hydraulic lifting systems meet the EMC requirements.

Not suitable for our glazing hatches.

In order to calculate the required lifting power, the following data must be taken into consideration:

- W = Width of the object to be lifted (e.g. 50" (1300 mm))
- G = Weight of the object to be lifted (e.g. 200 lbs (90 kg))
- S = Stroke of the piston in mm
- F = Required lifting power in kgf

The formula then works as follows

$$F = \frac{1}{2} \times \frac{W}{S} \times G = F$$

Example

$$F = \frac{1}{2} \times \frac{1300}{500} \times 90 = 117$$

In this case, system HL12500A featuring one cylinder with a lifting power of 125 kgf will be sufficient. If two cylinders must be installed an additional connection kit will be required; please see price list. Hydraulic fluid must be always ordered separately.

Type	Description	Voltage	Stroke inches (mm)	Lifting power
HL12500A	Complete system	12 Volt	19 ¹ / ₁₆ (500)	275 lbf (125 kgf)
HL12500B	Complete system	12 Volt	19 ¹ / ₁₆ (500)	705 lbf (320 kgf)
HL500	Additional cylinder		19 ¹ / ₁₆ (500)	275 lbf (125 kgf)
HL500B	Additional cylinder		19 ¹ / ₁₆ (500)	705 lbf (320 kgf)
SLP7/1620	Hose pillar 7/16"-20 UNF - 8 mm			

Set of limit switches

Type	Description
EHPESET	Set of limit switches (2 pieces)



EHPESET

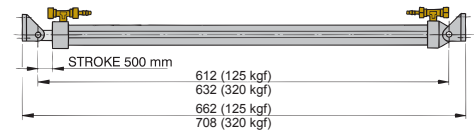
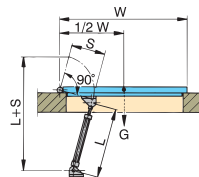

HL500A

HL500B

VENTILATION

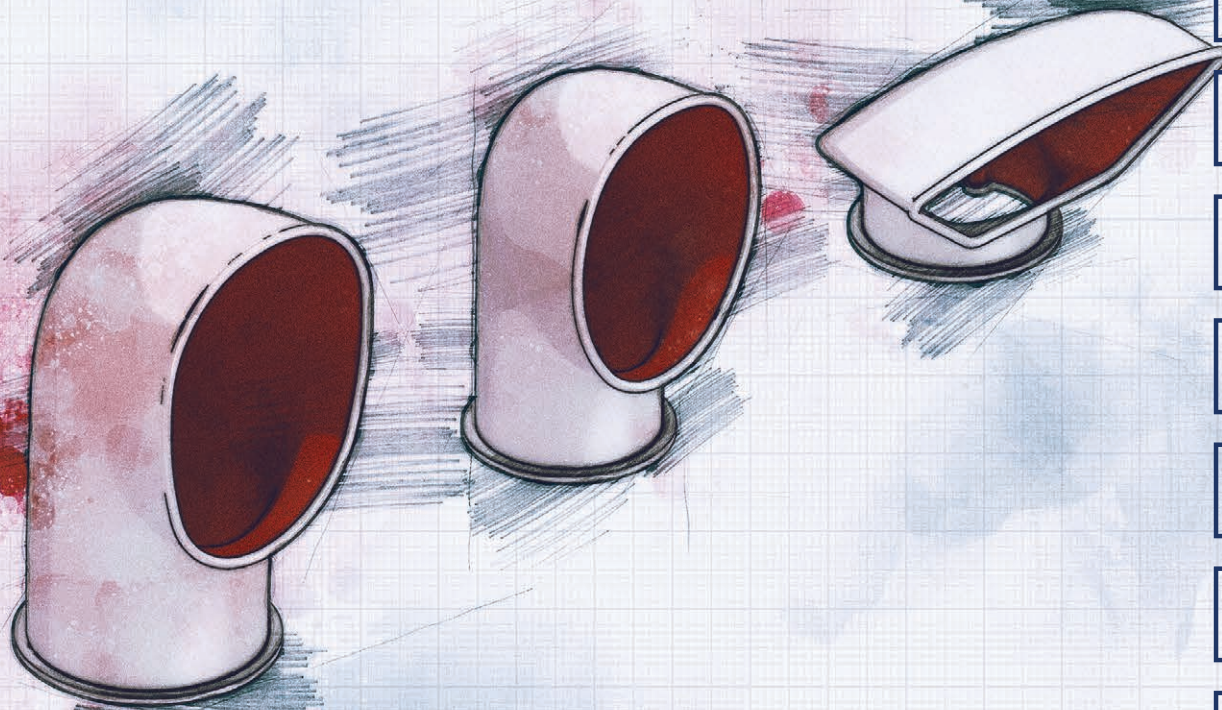

Overview VETUS ventilation

Deck ventilators see page 290



Shell ventilators see page 292



Electric extractor fans see page 293



Extraction ventilators see page 293



Cowl ventilators see page 295

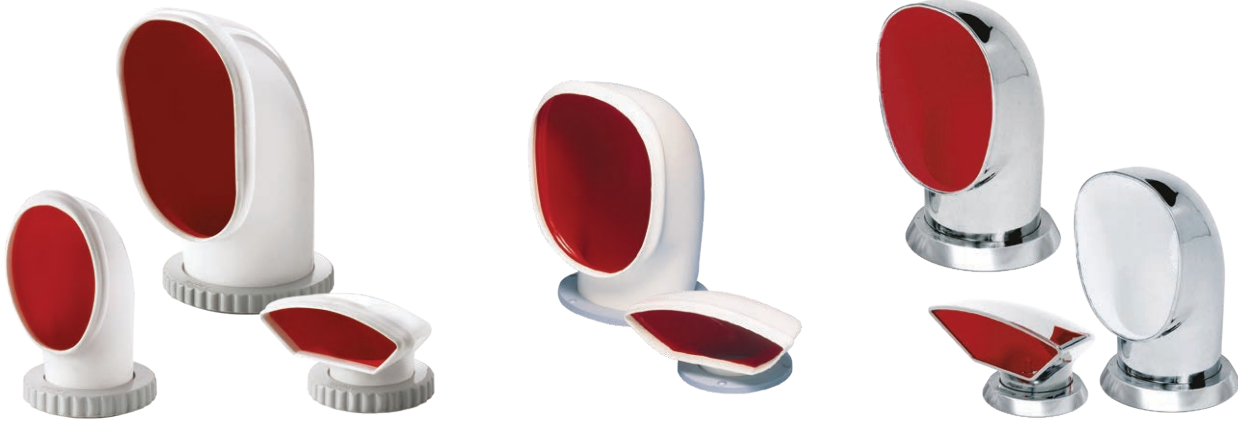

Accessories see page 296



Louvered air suction vents see page 298



VENTILATION

Good ventilation on your boat is very important if you have enclosed areas. It can help prevent mildew and bad odours and can save lives by taking carbon monoxide or petrol fumes out of the boat. When it comes down to making the best choice of ventilation system, VETUS has a wide range, even for the harshest conditions, both extremely safe and stylish as well. We at VETUS understand that ventilation isn't just a hole in your boat. When done correctly it can be a breath of fresh air!

There are 2 types of ventilation systems

1. Natural (passive) ventilation

Consists of vents, cowls and other permanent openings in the boat, designed to let air enter or exit using wind power or the boat's motion to move the air. Primarily used for living spaces.

2. Power extraction ventilators

Specifically designed to clear fumes from closed compartments. VETUS power extraction ventilators are ignition protected to prevent sparks and are built to resist overheating and corrosion.

Why choose VETUS ventilation

- One stop shop for a complete range to ensure a healthy on board climate
- We put safety first! Offering only certified ignition protected electric fans
- VETUS has ventilation products for any compartment, from engine room to sleeping quarters, from mushroom ventilators to extraction ventilators for the engine room
- VETUS UFO ventilators provide permanent boat ventilation, day and night, rain and splash proof, but also fully closable for the hardest conditions
- VETUS cowl ventilators are available in different designs, sizes and materials; the choice is yours!

For assistance in choosing the proper equipment and defining your ventilation system, please contact your VETUS dealer.

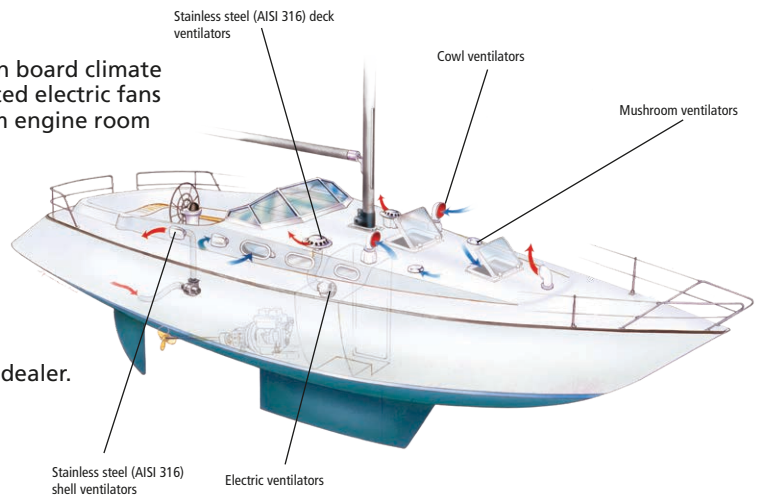

DECK VENTILATORS

Small cabins aboard boats must be ventilated adequately. It is very important when the temperature drops to keep the air humidity inside and outside as similar as possible to prevent condensation and its consequences, mould and mildew.

Open ventilators type UFO and UFOTRANS

Reliable, easy to maintain and good looking

These stainless steel (AISI 316) models with high-gloss polished shell cannot be closed thus ensuring permanent ventilation. They are rain and splash proof and can be used in combination with our electric extraction ventilators (see page 293). For dimensions please see diagram below.

Characteristics

- Free flow area (4.98 sq. inch (31,8 cm²))
- TRANS (UFOTR) version is translucent
- Supplied with mosquito screen and interior finishing ring

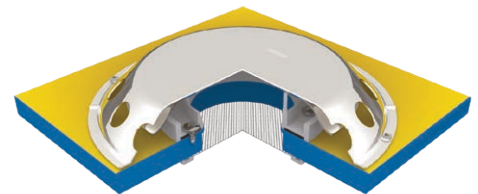

UFO



UFOTR

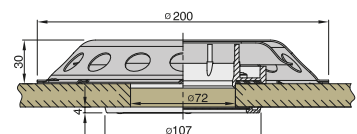

DECK VENTILATORS

Closeable deck ventilator type UFO2

Low profile deck ventilator with integral mushroom ventilator

This deck ventilator can be closed and made absolutely watertight. When opened the UFO2 ensures constant ventilation and still remains rain and splash proof. Its cover is made of high-gloss polished stainless steel (AISI 316) as is the internal mushroom ventilator. **CE marking: All**

Characteristics

- Free flow area 4.93 sq. inch. (30 cm²)
- Comes with an integral mosquito screen
- A synthetic finishing ring is supplied as standard



UFO2

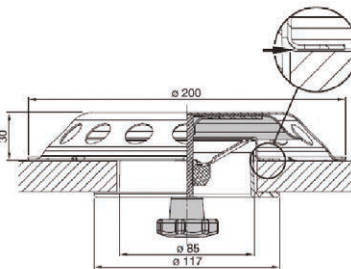
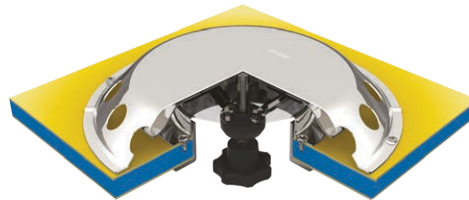

Type	Description	Free flow area sq. inch (cm ²)
UFO	Deck ventilator (stainless steel AISI 316)	4.98 (31,8)
UFOTR	Deck ventilator (stainless steel AISI 316)	4.98 (31,8)
UFO2	Closable deck ventilator (stainless steel AISI 316)	4.93 (30)

Mushroom ventilators type DARTAGN1, ATHOS1 and PORTOS1

High polished stainless steel (AISI 316) ventilators

These mushroom ventilators can be opened from the outside or from the inside using an integral knob. They include a mosquito screen and counter flange, both made of synthetic material. **CE marking All**



DARTAGN1



ATHOS1



PORTOS1

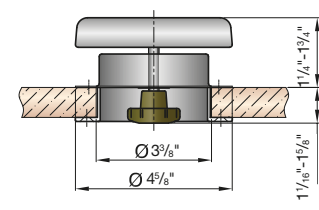
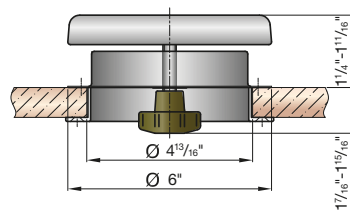
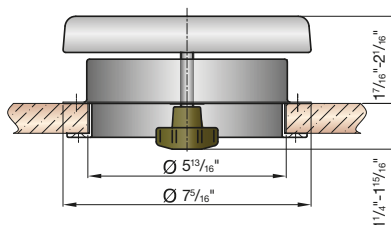

Type	Description	Free flow area sq. inch (cm ²)
DARTAGN1	Mushroom ventilator	10.8 (76)
ATHOS1	Mushroom ventilator	7.2 (45)
PORTOS1	Mushroom ventilator	4.7 (30)

SHELL VENTILATORS

Ventilator type TYPHOON

A redefined and updated 'traditional' shell ventilator

The outer cover of this shell ventilator is made of high-gloss polished stainless steel (AISI 316) and all other parts are of synthetic materials. When installed, no screws are visible. This intake or outlet ventilator is available in 2 sizes and suitable for horizontal or vertical use.

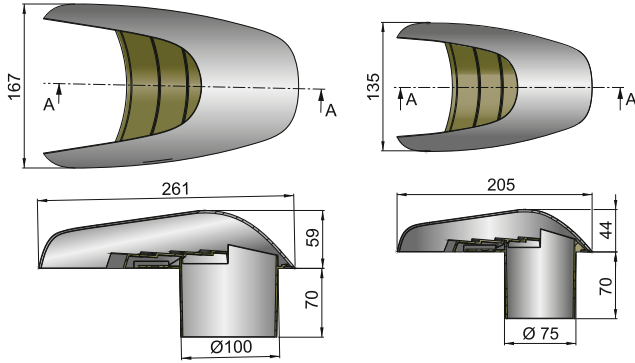

TYP75

TYP100



Type	Description	Free flow area sq. inch (cm ²)	Hose connection Ø inches (mm)
TYP75	Shell ventilator	4.7 (30)	3 (75)
TYP100	Shell ventilator	6.4 (41)	4 (100)

Ventilator type SCIROCCO

The ideal solution for ventilation openings to the engine room

This stainless steel (AISI 316) intake or outlet ventilator can be screwed directly on to hull or superstructure. A plastic base plate with water guard and hose connection is standard supply. This type can be installed horizontally or vertically.

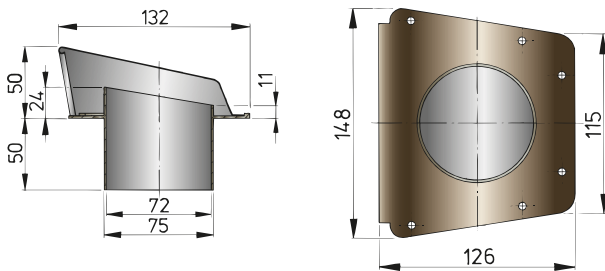

SCIROCCO



Type	Description	Free flow area sq. inch (cm ²)	Hose connection Ø inches (mm)
SCIROCCO	Shell ventilator	6 (38,5)	3 (76)

ELECTRIC VENTILATORS

Type FAN

Extremely low energy consumption and noise level

This barely audible electric ventilator is specified for saloons, cabins, galleys and toilets and is also ideal for heat extraction near a refrigerator. It can be installed in both ceilings and bulkheads. It can be used in combination with VETUS deck ventilators UFO and UFOTR (see page 290). With its long-life motor it can operate for at least 50.000 hours. VETUS recommends that every area should have an air-exchange rate of 3 to 4 times per hour.



FAN12
FAN24

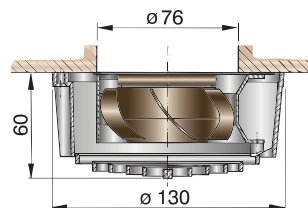
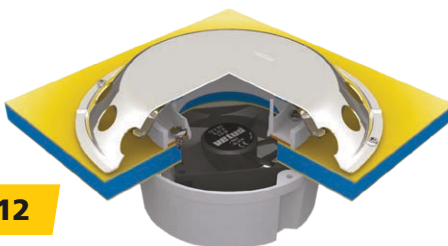

Specifications

- Available in 12 or 24 Volt (consumption 0,19 A or 0,11 A)
- Capacity 42 cfm (72 m³/hour)
- Provided with a 2-speed switch

Type	Description	Volt
FAN12	Electric ventilator	12
FAN24	Electric ventilator	24

EXTRACTION VENTILATORS

Type TWINLINE

The perfect heat extractor

The purpose of these ignition protected (IP67) extraction ventilators is to extract the heat from the engine room when the engine is not running or, when a petrol/gasoline engine is installed, to extract any possible petrol/gasoline fumes prior to starting the engine(s).

Specifications

- Complies with ISO 9097 Marine Standard
- Hose may be connected to Scirocco or Typhoon Shell ventilators

Note

VETUS does NOT recommend using extraction ventilators to provide air to the main engine(s)!

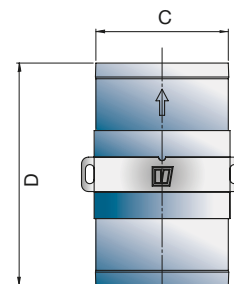
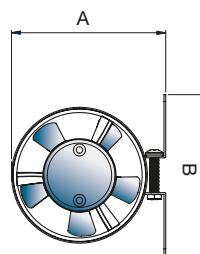

TWINLINEA

TWINLINEB

TWINLINEC

TWINLINED

Type	A inch (mm)	B inch (mm)	C inch (mm)	D inch (mm)	Capacity (m ³ /min)	I.D. hose Ø inch (mm)	Volt - Amp*
TWINLINEA	3 ¹ / ₂ (88.5)	3 ³ / ₈ (92.5)	3 (76)	5 ¹ / ₁₆ (128)	5	3 (76)	12 V - 2,8 A max.
TWINLINEB	4 ⁹ / ₁₆ (116)	4 ¹¹ / ₁₆ (119)	4 (101.6)	7 ¹ / ₁₆ (180)	7	4 (102)	12 V - 8,0 A max.
TWINLINEC	3 ¹ / ₂ (88.5)	3 ³ / ₈ (92.5)	3 (76)	5 ¹ / ₁₆ (128)	5	3 (76)	24 V - 1,6 A max.
TWINLINED	4 ⁹ / ₁₆ (116)	4 ¹¹ / ₁₆ (119)	4 (101.6)	7 ¹ / ₁₆ (180)	7	4 (102)	24 V - 5,0 A max.

* When using hose 10 mtr.



EXTRACTION VENTILATORS

Type VENT76A

Ideal for gallery, toilet and engine room

This extraction ventilator with Delrin Impeller is ignition protected (IP67) and complies with the ISO 9097 Marine Standard. It includes a mounting bracket and connection flange for in-line installation.

Note

VETUS does NOT recommend using extraction ventilators to provide air to the main engine(s)!

Specifications

- Available in 12 or 24 Volt (consumption 8 A or 4 A)
- Capacity 140 cu.ft (4 m³) per minute
- Suitable for Ø 3" (76 mm) I.D. hose

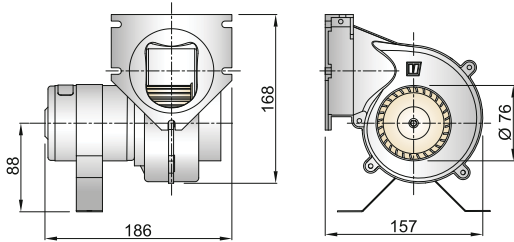

VENT7612A

VENT7624A



Type	Description	Volt	I.D.hose Ø inch (mm)
VENT7612A	Extraction ventilator	12	3 (76)
VENT7624A	Extraction ventilator	24	3 (76)

Connection flange

Type	Description
VENTKITA	Spare in-line hose connection flange for VENT76A

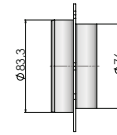
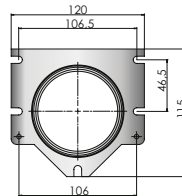

VENTKITA

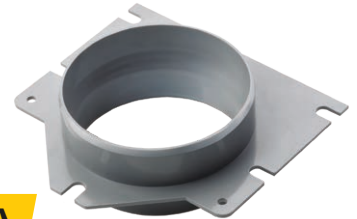

Type VENT178A

Suitable for bulkhead mounting and receiving air ducting hose

This extraction ventilator is ignition protected (IP67) and complies with the ISO 9097 Marine Standard.

Note

VETUS does NOT recommend using extraction ventilators to provide air to the main engine(s)!

Specifications

- Available in 12 or 24 Volt (consumption 6 A or 3 A)
- Capacity 12,2 m³ at 12 Volt or 12,5 m³ at 24 Volt D.C. per minute
- Suitable for receiving Ø 7" (178 mm) internal air ducting hose

VENT17812A

VENT17824A



Type	Description	Volt	I.D.hose Ø inch (mm)
VENT17812A	Extraction ventilator	12	7 (178)
VENT17824A	Extraction ventilator	24	7 (178)

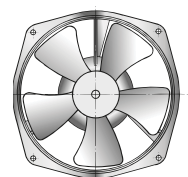
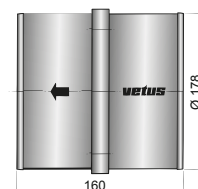

COWL VENTILATORS

Flexible PVC cowl ventilators

Excellent UV resistance

These cowl ventilators are made of Polyvinylchloride and the ring nuts and matching deck flanges are made of hard synthetic. The cowl ventilators are removable. A mosquito screen and a stainless steel (AISI 316) cover plate for closing off the cowl ventilator can be supplied as an option. Available in 3 sizes with a vertical opening and one with a horizontal opening. **Models with suffix S have a screwed down synthetic ring.**



YOGIS

TOMS

JERRYS



DONALDS



YOGI2

TOM2

JERRY2



DONALD2

Silicone cowl ventilators

Guaranteed to withstand the test of time!

These cowl ventilators are made of silicone. Silicone rubber is a very flexible synthetic material with a service temperature range between -148°F and +392°F (-100°C and +200°C). It is resistant to UV light and does not discolour, so it will always look like it's brand new. The cowl ventilators are removable and can be rotated after loosening the knurled base ring by hand. The ring nuts and mating deck flanges are made of hard plastic and the internal colour is red (RAL3020). A Monel mosquito screen and a stainless steel (AISI 316) cover plate for closing off the cowl ventilator can be supplied as an option. Available in 3 sizes with a vertical opening and one with a horizontal opening. **Models with suffix S have a screwed down synthetic ring.**



SAMOENS

CHINOOKS

LIBECS



TRAMONS



SAMOEN

CHINOOK

LIBEC



TRAMON

Stainless steel (AISI 316) cowl ventilators

Stylish appearance

Both the cowls and rings are made of cast stainless steel (AISI 316). The cowls rotate and are removable and the clamping ring can be tightened by hand. A threaded ring nut and deck ring are supplied as standard. A mosquito screen and a stainless steel (AISI 316) cover plate for closing off the cowl ventilator are optional. Available in 3 sizes with a vertical opening and one with a horizontal opening and with red or white interior.



YOG316R

TOM316R

JER316R



DON316R



YOG316WR

TOM316WR

JER316WR



DON316WR

For specifications see next page.



COWL VENTILATORS

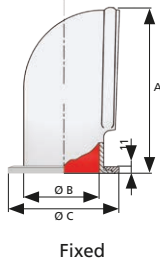
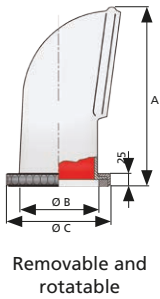

Dimensions Ø inch (mm)				Free flow area sq. inch (cm ²)	Material	Type:			
A	B	C 1)	C 2)			Removable and rotatable ¹⁾	Fixed ²⁾		
4 ⁵ / ₁₆ (110)	2 ¹⁵ / ₁₆ (75)	4 ¹⁵ / ₁₆ (125)	5 (127)	8.79 (44,2)	Silicone	TRAMON		TRAMONS	
					PVC	DONALD2		DONALDS	
4 ³ / ₈ (111)	2 ¹⁵ / ₁₆ (75)	4 ¹³ / ₁₆ (123)		8.79 (44,2)	Stainless steel - Red interior	DON316R		n.a.	n.a.
					Stainless steel - White interior	DON316WR		n.a.	n.a.
8 ¹ / ₁₆ (205)	2 ¹⁵ / ₁₆ (75)	4 ¹⁵ / ₁₆ (125)	5 (127)	8.79 (44,2)	Silicone	LIBEC		LIBECS	
					PVC	JERRY2		JERRYS	
8 ¹ / ₁₆ (205)	2 ¹⁵ / ₁₆ (75)	4 ¹³ / ₁₆ (123)		8.79 (44,2)	Stainless steel - Red interior	JER316R		n.a.	n.a.
					Stainless steel - White interior	JER316WR		n.a.	n.a.
9 ¹ / ₁₆ 230	3 ¹⁵ / ₁₆ (100)	6 (152)	6 (152)	12.2 (78,6)	Silicone	CHINOOK		CHINOOKS	
					PVC	TOM2		TOMS	
9 ¹ / ₁₆ 230	3 ¹⁵ / ₁₆ (100)	6 (153)		12.2 (78,6)	Stainless steel - Red interior	TOM316R		n.a.	n.a.
					Stainless steel - White interior	TOM316WR		n.a.	n.a.
11 ¹³ / ₁₆ (300)	4 ¹⁵ / ₁₆ (125)	6 ⁹ / ₁₆ (167)	7 ¹ / ₁₆ (179)	19 (122,8)	Silicone	SAMOEN		SAMOENS	
					PVC	YOGI2		YOGIS	
11 ¹³ / ₁₆ (300)	4 ¹⁵ / ₁₆ (125)	6 ⁹ / ₁₆ (167)		19 (122,8)	Stainless steel - Red interior	YOG316R		n.a.	n.a.
					Stainless steel - White interior	YOG316WR		n.a.	n.a.

ACCESSORIES FOR COWL VENTILATORS

Dorade box type BOX and BOXS

Prevents water from entering the ventilator

This box drains off any water entering the interior of the boat from the cowl ventilator and can be closed off entirely by means of the incorporated stainless steel (AISI 316) mushroom ventilator. Available in synthetic material or stainless steel (AISI 316), maximum deck thickness 1" (25 mm). For thicker decks use adaptor BOXAD. Choose the same size BOX as the diameter (B) of the cowl ventilator. A mosquito screen and a stainless steel (AISI 316) cover plate for closing off the cowl ventilator can be supplied as an option.

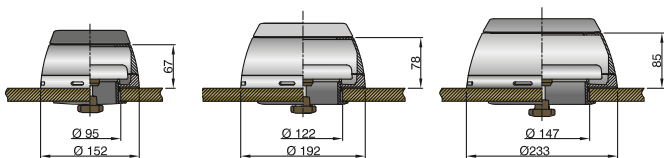

Type	Ø inch (mm)	Max. deck thickness inches (mm)	Material
BOX75	2 ¹⁵ / ₁₆ (75)	1 (25)	Synthetic
BOX100	3 ¹⁵ / ₁₆ (100)	1 (25)	Synthetic
BOX125	4 ¹⁵ / ₁₆ (125)	1 (25)	Synthetic
BOXS75	2 ¹⁵ / ₁₆ (75)	1 (25)	Stainless steel (AISI316)
BOXS100	3 ¹⁵ / ₁₆ (100)	1 (25)	Stainless steel (AISI316)
BOXS125	4 ¹⁵ / ₁₆ (125)	1 (25)	Stainless steel (AISI316)

ACCESSORIES FOR COWL VENTILATORS

Dorade box type DJBOX, TBOX and YBOX

Synthetic boxes

This synthetic box drains off any water entering the ventilator and can be closed off entirely by means of the incorporated stainless steel (AISI 316) mushroom ventilator. The screw down deck ring supplied with the cowl ventilator can be easily fitted to the dorade box using the supplied nuts and bolts. A mosquito screen and a stainless steel (AISI 316) cover plate for closing off the cowl ventilator can be supplied as an option.

Note These boxes are not suitable for cowl ventilator type S.

Type	Description
YBOX	Dorado box for YOGI / SAMOEN, including mushroom ventilator
TBOX	Dorado box for TOM / CHINOOK, including mushroom ventilator
DJBOX	Dorado box for DONALD / JERRY / TRAMON / LIBEC, including mushroom ventilator

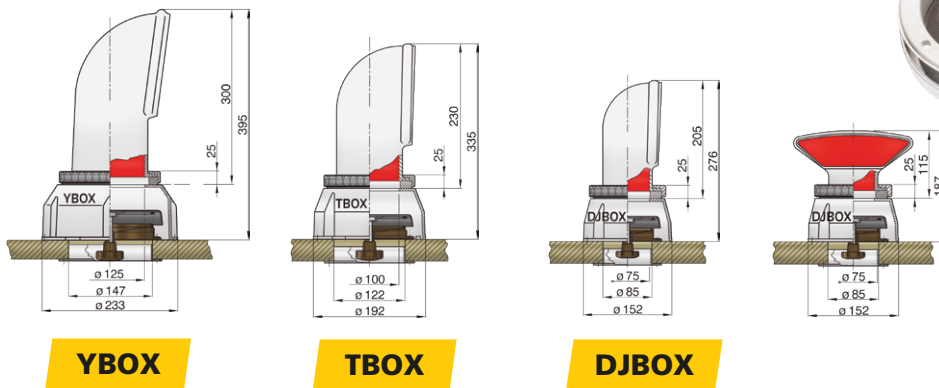

Adaptor to fit dorade box type BOX

For use with thicker decks

The type BOX and BOXS dorade boxes can be mounted invisibly to any deck up to 25 mm thickness. For larger deck thicknesses VETUS offers the BOXAD adapter flange. This flange can be mounted to the dorade box using the counter flange, after which the adapter can be screwed down to the deck.

The adapter flanges are made of high gloss polished stainless steel (AISI 316) to match the stainless steel (AISI 316) cowl ventilators and dorade boxes.

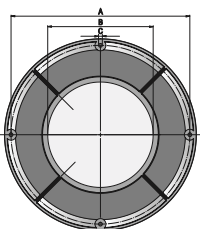

Type	Suitable for	A Ø inches (mm)	B Ø inches (mm)	C Ø inches (mm)	Thickness inches (mm)
BOXAD75	BOX75, BOXS75	6 ³⁷ / ₆₄ (167)	3 ⁴⁷ / ₆₄ (95)	1 ³ / ₆₄ (5.2)	1/4 (6)
BOXAD100	BOX100, BOXS100	7 ⁶¹ / ₆₄ (202)	4 ⁴³ / ₆₄ (118.5)	1 ³ / ₆₄ (5.2)	1/4 (6)
BOXAD125	BOX125, BOXS125	9 ⁴¹ / ₆₄ (245)	5 ¹¹ / ₁₆ (144.5)	1 ³ / ₆₄ (5.2)	1/4 (6)

Ring and nut type RING

Complete set

This set consists of a stainless steel (AISI 316) ring NUT, a male deck ring and fastening key. A ring nut set is available for each size of plastic cowl ventilator and can be retrofitted to existing cowls.

Type	Description
RING75	Ring and nut, AISI 316, for cowl ventilator DONALD / JERRY / TRAMON / LIBEC
RING100	Ring and nut, AISI 316, for cowl ventilator TOM / CHINOOK
RING125	Ring and nut, AISI 316, for cowl ventilator YOGI / SAMOEN

Type	Description
SET75	Cover plate and mosquito screen S/S 316 for all cowl ventilators Ø 2 ¹⁵ / ₁₆ " (75 mm)
SET100	Cover plate and mosquito screen S/S 316 for all cowl ventilators Ø 3 ¹⁵ / ₁₆ " (100 mm)
SET125	Cover plate and mosquito screen S/S 316 for all cowl ventilators Ø 4 ¹⁵ / ₁₆ " (125 mm)



RING

LOUVRED AIR SUCTION VENTS

In addition to combustion air, an engine also requires sufficient ventilation air to dissipate the residual heat. The required volume of ventilation air is about the same as the combustion air needed which is approximately 6.1 m³ per kW (4.5 m³ per hp) per hour based on a maximum air velocity of 3 m/sec. The design of these VETUS air suction vents is based on these principles. The model numbers (see tables below) relate to the engine horsepower for which they are suitable. So for example, a 40HP engine could use 1 x type 40, or 2 x type 20 vents.

Type ASV

This type has a polished anodised aluminium frame with grilles of naturally anodised aluminium.



ASV

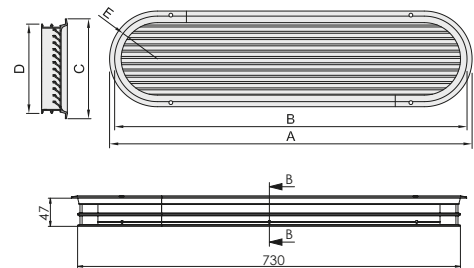

Type	A inch (mm)	B = Cutout inch (mm)	C inch (mm)	D = Cutout inch (mm)	E = Cutout radius inch (mm)	Free flow area in in ² (dm ²)*
ASV020A	11 ¹³ / ₁₆ (300)	11 (280)	4 ⁵ / ₈ (117)	3 ¹³ / ₁₆ (97)	R 1 ²⁹ / ₃₂ (48.5)	12.9 (0.83)
ASV025A	13 ¹³ / ₁₆ (350)	13 (330)	4 ⁵ / ₈ (117)	3 ¹³ / ₁₆ (97)	R 1 ²⁹ / ₃₂ (48.5)	15.5 (1.00)
ASV030A	14 ¹³ / ₁₆ (360)	13 ³ / ₈ (340)	5 ¹ / ₈ (130)	4 ³ / ₈ (110)	R 2 ³ / ₁₆ (55)	18.9 (1.22)
ASV040A	17 ³ / ₄ (450)	16 ¹⁵ / ₁₆ (430)	5 ¹ / ₈ (130)	4 ³ / ₈ (110)	R 2 ³ / ₁₆ (55)	24.7 (1.59)
ASV050A	19 ⁵ / ₁₆ (490)	18 ¹ / ₂ (470)	5 ³ / ₄ (146)	5 (126)	R 2 ¹ / ₂ (63)	31.3 (2.02)
ASV060A	22 ⁷ / ₁₆ (570)	21 ¹ / ₁₆ (550)	5 ³ / ₄ (146)	5 (126)	R 2 ¹ / ₂ (63)	37.4 (2.41)
ASV070A	23 ¹ / ₄ (590)	22 ⁷ / ₈ (570)	6 ¹ / ₄ (159)	5 ¹ / ₂ (139)	R 2 ³ / ₄ (69.5)	43.9 (2.83)
ASV080A	26 (660)	25 ³ / ₁₆ (640)	6 ¹ / ₄ (159)	5 ¹ / ₂ (139)	R 2 ³ / ₄ (69.5)	49.8 (3.21)
ASV090A	26 ³ / ₈ (670)	25 ⁵ / ₈ (650)	6 ³ / ₄ (172)	6 (152)	R3 (76)	56.2 (3.63)
ASV100A	28 ³ / ₄ (730)	28 (710)	6 ³ / ₄ (172)	6 (152)	R3 (76)	62 (4.00)
ASV125A	29 ¹ / ₂ (750)	28 ³ / ₄ (730)	7 ¹³ / ₁₆ (198)	7 (178)	R 3 ¹ / ₂ (89)	78 (5.03)
ASV150A	35 (890)	34 ¹ / ₄ (870)	7 ¹³ / ₁₆ (198)	7 (178)	R3 ¹ / ₂ (89)	94.2 (6.03)

* 1 dm² = 100 cm²

Type SSV

Type SSV is made of high gloss stainless steel (AISI 316) and has anodised aluminium louvres.



SSV

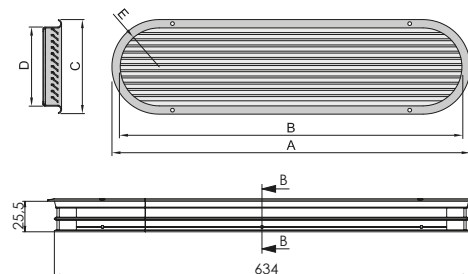

Type	A inch (mm)	B = Cutout inch (mm)	C inch (mm)	D = Cutout inch (mm)	E = Cutout radius inch (mm)	Free flow area in in ² (dm ²)*
SSV070	23 ¹ / ₄ (590)	22 ⁷ / ₈ (570)	6 ¹ / ₄ (159)	5 ¹ / ₂ (139)	R 2 ³ / ₄ (69.5)	43.9 (2.83)
SSV080	26 (660)	25 ³ / ₁₆ (640)	6 ¹ / ₄ (159)	5 ¹ / ₂ (139)	R 2 ³ / ₄ (69.5)	49.8 (3.21)
SSV090	26 ³ / ₈ (670)	25 ⁵ / ₈ (650)	6 ³ / ₄ (172)	6 (152)	R3 (76)	56.2 (3.63)
SSV100	28 ³ / ₄ (730)	28 (710)	6 ³ / ₄ (172)	6 (152)	R3 (76)	62 (4.00)
SSV125	29 ¹ / ₂ (750)	28 ³ / ₄ (730)	7 ¹³ / ₁₆ (198)	7 (178)	R 3 ¹ / ₂ (89)	78 (5.03)
SSV150	35 (890)	34 ¹ / ₄ (870)	7 ¹³ / ₁₆ (198)	7 (178)	R3 ¹ / ₂ (89)	94.2 (6.08)

* 1 dm² = 100 cm²

LOUVRED AIR SUCTION VENTS

Type SSVL

The frame and grilles of this type are made of high gloss polished stainless steel (AISI 316).

SSVL

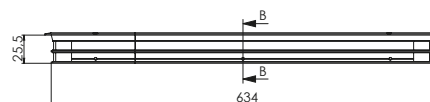
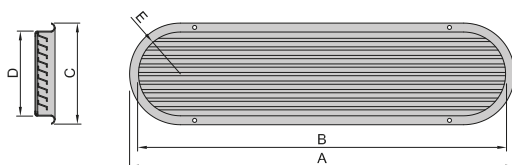

Type	A inch (mm)	B = Cutout inch (mm)	C inch (mm)	D = Cutout inch (mm)	E = Cutout radius inch (mm)	Free flow area in in ² (dm ²)*
SSVL070	23 ¹ / ₄ (590)	22 ⁷ / ₈ (570)	6 ¹ / ₄ (159)	5 ¹ / ₂ (139)	R 2 ³ / ₄ (69.5)	43.9 (2.83)
SSVL080	26 (660)	25 ³ / ₁₆ (640)	6 ¹ / ₄ (159)	5 ¹ / ₂ (139)	R 2 ³ / ₄ (69.5)	49.8 (3.21)
SSVL090	26 ³ / ₈ (670)	25 ⁵ / ₈ (650)	6 ³ / ₄ (172)	6 (152)	R3 (76)	56.2 (3.63)
SSVL100	28 ³ / ₄ (730)	28 (710)	6 ³ / ₄ (172)	6 (152)	R3 (76)	62 (4.00)
SSVL125	29 ¹ / ₂ (750)	28 ³ / ₄ (730)	7 ¹³ / ₁₆ (198)	7 (178)	R 3 ¹ / ₂ (89)	78 (5.03)
SSVL150	35 (890)	34 ¹ / ₄ (870)	7 ¹³ / ₁₆ (198)	7 (178)	R3 ¹ / ₂ (89)	94.2 (6.08)

* 1 dm² = 100 cm²

Type ASVREC

Rectangular louvred air suction vent

The frames of this type are made of polished anodised aluminium and the grilles of naturally anodised aluminium.

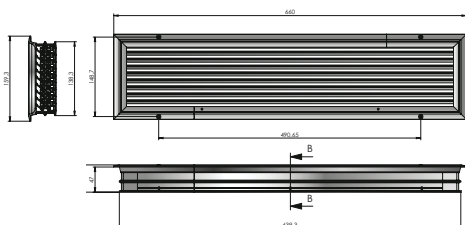

ASVREC



Type	A inch (mm)	B = Cutout inch (mm)	C inch (mm)	D = Cutout inch (mm)	Free flow area in in ² (dm ²)*
ASVREC20	11 ¹³ / ₁₆ (300)	11 (280)	4 ⁵ / ₈ (117)	3 ¹³ / ₁₆ (97)	43.9 (0.83)
ASVREC30	14 ¹³ / ₁₆ (360)	13 ³ / ₈ (340)	5 ¹ / ₈ (130)	4 ⁷ / ₈ (110)	49.8 (1.25)
ASVREC40	17 ³ / ₄ (450)	16 ¹⁵ / ₁₆ (430)	5 ¹ / ₈ (130)	4 ⁷ / ₈ (110)	56.2 (1.62)
ASVREC50	19 ⁵ / ₁₆ (490)	18 ¹ / ₂ (470)	5 ³ / ₄ (146)	5 (126)	62 (2.05)
ASVREC60	22 ⁷ / ₁₆ (570)	21 ¹¹ / ₁₆ (550)	5 ³ / ₄ (146)	5 (126)	72 (2.45)
ASVREC70	23 ³ / ₄ (590)	22 ⁷ / ₈ (570)	6 ¹ / ₄ (159)	5 ¹ / ₂ (139)	78 (2.85)
ASVREC80	26 (660)	25 ³ / ₁₆ (640)	6 ¹ / ₄ (159)	5 ¹ / ₂ (139)	94.2 (3.25)

* 1 dm² = 100 cm²

Note

VETUS can supply louvred air vents in other shapes and sizes to special order.

DORADE BOXES

Type DBOX for louvered air suction vents

All standard air suction vents can be supplied with a synthetic dorade box as an option (except type ASVREC).

Type	Specifications
DBOX020	Dorade box for ASV, SSV, SSVL, type 20
DBOX025	Dorade box for ASV, SSV, SSVL, type 25
DBOX030	Dorade box for ASV, SSV, SSVL, type 30
DBOX040	Dorade box for ASV, SSV, SSVL, type 40
DBOX050	Dorade box for ASV, SSV, SSVL, type 50
DBOX060	Dorade box for ASV, SSV, SSVL, type 60

Type	Specifications
DBOX070	Dorade box for ASV, SSV, SSVL, type 70
DBOX080	Dorade box for ASV, SSV, SSVL, type 80
DBOX090	Dorade box for ASV, SSV, SSVL, type 90
DBOX100	Dorade box for ASV, SSV, SSVL, type 100
DBOX125	Dorade box for ASV, SSV, SSVL, type 125
DBOX150	Dorade box for ASV, SSV, SSVL, type 150



DBOX

ROUND AIR SUCTION VENTS

Type ERV

Air suction vent with rotating connector

This vent is suitable for up to 16 hp of engine power. For a 60 hp engine you would need 4 of these air suction vents of which 2 should be fitted to port and 2 to starboard.

Type ERV is made of stainless steel (AISI 316) and has a synthetic rotating connector which functions as a watertight dorade box. The free flow area is 10.2 sq.inch (0,66 dm²). No matching hose is supplied.



ERV110A

Type	Description
ERV110A	Round air suction vent type 110, with stainless steel (AISI 316) grille and synthetic housing

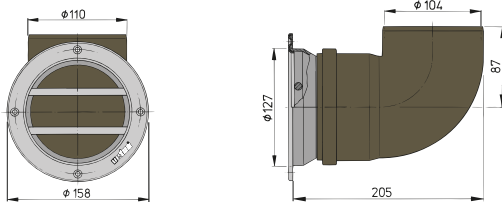

ACCESSORIES

Hose for blowers (ventilators)

Suitable for VETUS shell ventilators and extraction ventilators. For a complete overview of hoses and available sizes see page 404.

BLHOSE





ANCHORING SYSTEMS



50 YEARS
MAXWELL
SINCE 1969



Maxwell Product Innovation

Maxwell equipment is born of innovation and backed by years of experience in the manufacture of the world's highest quality anchor windlasses, ancillary deck gear and stern handling products.

Maxwell's innovative approach to design resulted in the introduction of automatic rope/chain windlasses to the global marine market during the mid 1990's. These were a radical departure from all other windlasses, revolutionary in design and technical features.

Building on the success of these products, Maxwell designed and developed an exciting RC range of automatic rope/chain windlasses. Maxwell broke the design barriers with the development of a vertical and horizontal rope/chain windlass range incorporating two unique and internationally patented features. The RC and HRC Series attest to Maxwell's ongoing commitment to innovative design and development.

Maxwell continues to evolve its existing range of proven windlasses and capstans. The RC12 is the culmination of Maxwell's evolution of a full range of automatic rope/chain windlasses suitable for use on vessels from 4.5metres (15 feet) to over 22 metres (75 feet).

Maxwell's ongoing commitment to product development can also be seen in the upgrading of their 'traditional' and continually popular vertical VWC Series. Stalwarts since the early nineties, the VWC windlasses were always great performers and now, with advanced engineering features incorporated into their improved designs, they work even better.

Maxwell recognises that boat owners not only want equipment that works flawlessly, they want products that look good as well. To this end, Maxwell designers spend countless hours improving the look, functionality and robustness of all Maxwell products.

With an ongoing commitment to excellence, product innovation, research and development, you can count on Maxwell to secure your investment!



HRCFF

The compact HRCFF6, HRCFF7 and HRCFF8 are Maxwell's horizontal versions of their innovative vertical RC Series automatic rope/chain windlasses. Packed with original and proven features, such as automatic 'Free Fall' and including the patented rode management technology developed by Maxwell, the HRCFF6, HRCFF7 and HRCFF8 have become industry icons.



RC12HD

The RC12HD has been designed to meet typical classification society requirement or regulations. This design is particularly well suited to vessels requiring high service speeds such as patrol vessels as the reduced weight of rope/chain combination rodes removes weight from the front of the vessel.



TASMAN

Our all-new Tasman Series has a powerful motor and is highly reliable; ready for whatever situation or adventure you can throw at it. The gearbox, made from marine grade aluminium, is anodised for optimal protection. It can be positioned in 14 positions with 15° increments and has a large diameter stainless steel output hub.



An Introduction to Maxwell's Products

To make the proper selection in anchor-handling equipment it is important to give careful consideration to the style and size of boat, the anticipated anchoring conditions, and the weight and type of ground tackle. (Refer to 'Which Winch' article on page 305). Maxwell has an extensive range of windlasses for all types of ground tackle, bow configurations, locker spaces and power requirements including:

- The vertical stainless steel RC Series and the horizontal HRC Series automatically handle rope/chain combination rodes and are suitable for boats from 4.5 metres (15 feet) up to approximately 22 metres (75 feet)
- The evolutionary RC12 Series automatically handles rope/chain combination rodes and is suitable for lighter displacement vessels up to approximately 24 metres (80 feet)
- The multipurpose VC (Vertical Capstan) Series, which can be used for all types of line handling
- The traditional rope and chain VW (Vertical Windlass) Series, designed for manually handling a rope and chain combination anchor rode joined by a conventional shackle and eye splice. The exception being the hybrid VW10, see page 318
- The VWC (Vertical Windlass/Capstan) and HWC (Horizontal Windlass/Capstan) Series, which handle chain only rodes automatically

VERTICAL OR HORIZONTAL - MAXWELL OFFERS BOTH

Vertical systems have several advantages: They take up less space on deck and are easier to maintain. They are less expensive than equivalent horizontal models. Chain, or rope/chain alignment with the bow roller, while not as critical as horizontal windlass alignment, should be within a tolerance of about +/- 2% for smooth retrieval of chain or rope/chain. Rode (rope/chain) alignment with RC Series winches is more critical (consult Owner's Manual). With vertical systems more chain is in contact with the chainwheel thus minimising the possibility of chain jump. Line-pull on the warping drum can be in any direction, as opposed to fore and aft only on horizontal models.

Horizontal models have the advantage of being better suited to applications where there is extreme deck thickness (over 200 mm - 8"), limited below deck accessibility or when two anchors must be handled from one winch. Each winch is available with a circuit breaker of an appropriate size to provide electrical protection during normal operation of the winch. Maxwell capstan winches and anchor windlasses fitted with capstan drums are manufactured with Maxwell's fluted stainless steel design to ensure the best possible grip and control of rope lines or rodes.

Maxwell products are distributed and supported worldwide by an extensive service network.

'CHAIN' OR 'ROPE AND CHAIN'?

The two options for use with windlasses:

CHAIN ONLY

A rode consisting entirely of short link anchoring chain provides the ultimate in holding security. Chafe resistance combined with excellent catenary effect ensure the best holding, suitable for use on all Maxwell anchoring windlasses including those designed for use with rope/chain combination rodes.

ROPE AND CHAIN

A rode consisting of a combination of short link chain and nylon rope, provides a good compromise between holding security, weight and shock absorption. A length of chain attached to the anchor provides good chafe resistance for those portions of the rode often touching the sea floor, the remainder of the rode being nylon rope which significantly reduces the weight of the rode and also provides some shock absorbing and noise cancelling. This type of rode is only suitable for use with Maxwell windlasses designed specifically for rope/chain combination rodes.

The length of the chain or rope is only limited by chain locker size so it is possible to have for example 60 m of chain (used for most anchoring) and 100 m of rope (for those times where it is required to anchor in deep water). It is not recommended to leave a vessel anchored on the rope portion of the rode for extended periods without monitoring of the rope condition to ensure chafe does not become an issue.

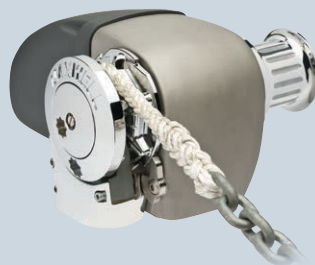

WINDLASS AND CAPSTAN SELECTION CHART

This chart serves as a basic guide to assist in selecting the appropriate anchor winch system for your boat.

Please note: Size, displacement and type of vessel, as well as anchoring conditions, must be taken into consideration when selecting an anchor winch. Vessels of heavy

displacement and/or high windage will require larger windlasses. All systems assume the use of a chain stopper, chain snubber or mooring cleat to remove the load when setting or breaking the anchor loose. The maximum pulling capacity of the windlass should not be less than three times the total weight of the ground tackle. Should you require any assistance or information, please do not hesitate to contact Maxwell Marine or any of our distributors or service centres world-wide.

WINCH Series, Type & Size		CHAIN SIZE Use of short link chain is essential				BOAT LENGTH METRES FEET															
		6/7 mm 1/4"	8 mm 5/16"	10/11 mm 3/8"	13 mm 1/2"	4.5 15	6.1 20	7.6 25	9.2 30	10.7 35	12.2 40	13.7 45	15.3 50	16.8 55	18.5 60	20 65	21.5 70	22.8 75	80 → 100		
RC6 Automatic Rope & Chain	RC6 only V	●				LIGHT HEAVY															
	RC8-6 only V	●				LIGHT HEAVY															
RC8 Automatic Rope & Chain	RC8-8 only V		●			LIGHT HEAVY															
	RC10-8 only V		●			LIGHT HEAVY															
RC10 Automatic Rope & Chain	RC10-10 only V			●		LIGHT HEAVY															
	RC12-10 only V			●		LIGHT HEAVY															
RC12 Automatic Rope & Chain	RC12-12 only V				●	LIGHT HEAVY															
	RC12HD10					LIGHT HEAVY															
RC12HD	RC12HD12					LIGHT HEAVY															
	ANCHORMAX™ only V					LIGHT HEAVY															
HRCFF Automatic Rope & Chain	HRCFF-6 only H	●				LIGHT HEAVY															
	HRCFF-7 only H	●				LIGHT HEAVY															
	HRCFF-8 only H	●	●			LIGHT HEAVY															
	HRC10-8 only H		●			LIGHT HEAVY															
HRC10 Automatic Rope & Chain	HRC10-10 only H			●		LIGHT HEAVY															
	TASMAN 6 only H					LIGHT HEAVY															
TASMAN	TASMAN 8 only H					LIGHT HEAVY															

VC All Rope	VWC Rope & Chain	VWC Chain only	HWC Rope & Chain	V - Vertical Configuration -		H - Horizontal Configuration		BOAT LENGTH														
				500 only v	VW10 only v	1000 only v	1500 only v	2500 V and H	3500 V and H	4000	4500	6000 →	LIGHT HEAVY	LIGHT HEAVY	LIGHT HEAVY	LIGHT HEAVY	LIGHT HEAVY	LIGHT HEAVY	LIGHT HEAVY	LIGHT HEAVY	LIGHT HEAVY	
●	●			●																		
	●				●																	
●	●	●		●	●																	
●	●	●	●	●	●	●																
	●	●	●			●	●															

This chart refers to anchor windlass selection only. When selecting a stern capstan for the same boat, Maxwell uses one size smaller drive, or down to a minimum of 50% of the pull rating of the windlass (unless specified otherwise).



RC6



RC8



RC10



RC12



ANCHORMAX

WHICH WINCH? (Italicised items - refer to glossary, page 341)

There are a number of important criteria to be considered in selecting the correct anchor winch. These include the vessel size, displacement, windage, anchor size and *rode* selection. Practicalities such as locker space and depth of fall for the rode also play a part in deciding which *windlass* is ideal for you.

Maxwell Marine's range of windlasses and capstans is extensive, with models to suit boats up to 120 metres (over 380 feet). This section aims to simplify the selection process by taking you step by step through all the criteria that needs to be considered when choosing a windlass or capstan.

WHAT SIZE WINDLASS OR CAPSTAN FOR MY BOAT?

Consider the overall length and displacement (either light or heavy) of your boat and use the chart on the opposite page to identify the most suitable windlass or capstan for your vessel.

VERTICAL OR HORIZONTAL CONFIGURATION?

The two basic types of windlasses are differentiated by the drive shaft orientation. Deck thickness and underdeck space are the two main considerations when deciding which of the two types to fit.

Vertical windlasses make up the majority of anchor winch sales. They are characterised by situating the *capstan* and/or *gypsy* (topworks) above the deck and the motor and gearbox below. Vertical windlasses provide a 180° wrap of the anchor rode around the chainwheel giving optimal chain control, minimising slippage and jumping.

Horizontal windlasses are mounted completely above deck with gypsy and capstan located to either side. They provide a 90° wrap of the anchor rode around the chainwheel.

HOW MUCH SPACE DO I NEED IN MY CHAIN LOCKER?

Deck thickness and locker space play an important role in deciding whether to install a *vertical* or *horizontal* windlass. Estimating or measuring the depth of fall of the rode into the anchor locker may dictate which type of windlass is most suitable for your vessel. Calculating the depth of fall differs for horizontal chain only windlasses and for vertical chain or rope/chain windlasses (see diagram below).

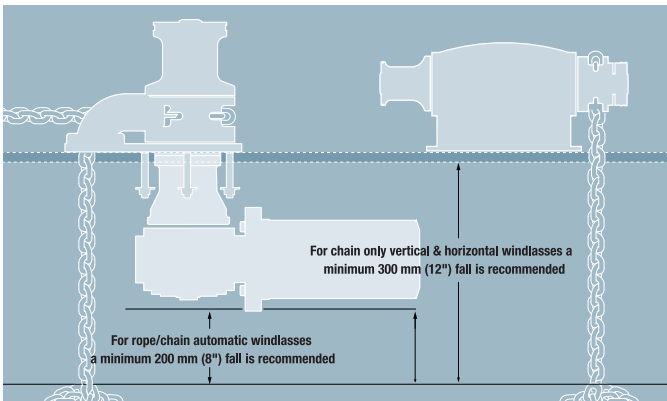

Recommended minimum fall distances are measured from the top of rode pile (chain or rope/chain) after complete retrieval of the anchor.

ROPE SELECTION

Rope and, particularly chain, selection is extremely important. Deciding on the right anchor winch for your boat depends on the size, not only of the boat, but also the ground tackle. Maxwell anchor winches and capstans are designed to take chain only, rope only or a combination of both. Automatic rope/chain systems are now commonly used on boats up to 22 metres (75 feet). Consequently, Maxwell's HRCFF6, HRCFF7, HRCFF8, HRC10, RC6, RC8, RC10 and the evolutionary RC12 automatic rope/chain systems have become increasingly popular, as they offer the added benefit of less weight in the bow with the ability to carry an increased amount of rode. Chain only systems remain popular on heavier displacement sail and motor yachts. There are two main types of anchor chain. Short link chain is most commonly used on small and medium sized boats while stud link chain is generally used on much larger vessels such as Superyachts.

The latter is characterised by a stud (bar) joining the two sides of the link preventing them from deforming when overloaded. High test or calibrated short link chain should always be used. Long or regular link chain should not be used with anchor windlasses.

There are a wide variety of both metric (mm) and imperial (inches) chain sizes available and these will have bearing on your final windlass decision. It is important that the right size and right grade of chain is used to ensure a correct fit of the links to the gypsy. If the chain is not matched to the chainwheel problems may occur, such as the chain jumping off the gypsy or the chain jamming as it will not feed smoothly through the chain pipe. As chain to chainwheel compatibility is so important, Maxwell Marine supplies chainwheels to fit just about every known chain available on today's international market.

DC, AC OR HYDRAULIC?

The wattage of a DC electric motor is not the important factor. Rather it is the efficiency of the whole winch, including the gearbox and motor, which counts. With the increasing popularity of powerful and compact on-board generators, AC powered winches are becoming a practical consideration for bigger boats. Hydraulic systems provide another power source well worth considering as they have the advantage of constant speed under all load conditions and can be run almost constantly while coupled with safe guards such as pressure relief valves. Modern hydraulic systems offer an integrated, low maintenance and efficient, centrally managed, power pack.

WHAT PULL CAPABILITY WILL I NEED?

The only meaningful way to rate anchor winch performance is by looking at what it will lift and at what speed. The two things to consider are (a) the *maximum pull* capability and (b) the *working load* of the winch. Maximum pull (sometimes referred to as stall load) is the maximum short term or instantaneous pull of the winch. Working load is generally rated at about one third of the maximum pull and is usually considered to be the load that the winch is pulling once the anchor is off the bottom. To determine your required maximum pull capability, complete the calculation below.

1. Calculate ground tackle weight (anchor + chain + rope = ground tackle)

$$\text{eg: ANCHOR } 30 \text{ kg/66 lbs} + 18 \text{ m/60 ft CHAIN } 45 \text{ kg/100 lbs} + 61 \text{ m/200 ft ROPE } 12 \text{ kg/ 26 lbs} = \text{GROUND TACKLE } 87 \text{ kg/192 lbs}$$

2. Calculate the maximum pull (total ground tackle x 3 = Maximum pull)

Safety guidelines suggest that the pulling capacity of the windlass should not be less than 3 times the total weight of the ground tackle.

$$\text{eg: GROUND TACKLE } 87 \text{ kg/192 lbs} \times 3 = \text{MAXIMUM PULL } 261 \text{ kg/576 lbs}$$

In this instance an **HRC8, HRC10, RC8, RC10, or VW1000** would be suitable, providing the chain and rope size is applicable to the windlass being considered. The maximum pull of 261 kg/576 lbs is well within the capability of all these anchor winches.

SAFETY AND SECURITY TIPS

Circuit breaker/isolators are used in the installation of any DC electric windlass to provide protection to motor and cables should the windlass be overloaded. Accessories such as *chain stoppers* or chain snubbers must be used for safe anchoring, the avoidance of unintentional self-launching of the anchor and for the prevention of damage to your anchor winch. You should never anchor off your winch or use your winch to pull your boat to the anchor spot. The anchor winch is designed to lift a dead weight and should not be subjected to the strain of your boat riding at anchor. If you think the winch you are considering may be too small, then go to the next size up. Better to have excess lifting capacity than not enough!

Maxwell Marine and their agents or distributors offer free and helpful advice should you have any questions. Alternatively, refer to Maxwell's website: www.maxwellmarine.com

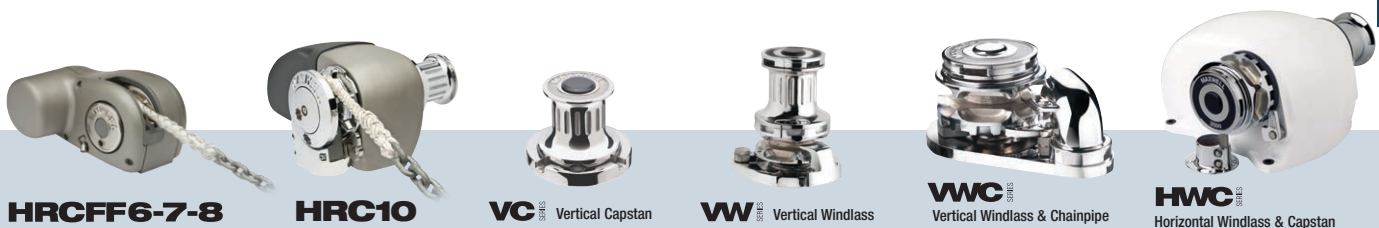

HRCFF6-7-8

HRC10

VC SERIES Vertical Capstan

WW SERIES Vertical Windlass

VWC SERIES Vertical Windlass & Chainpipe

HWC SERIES Horizontal Windlass & Capstan



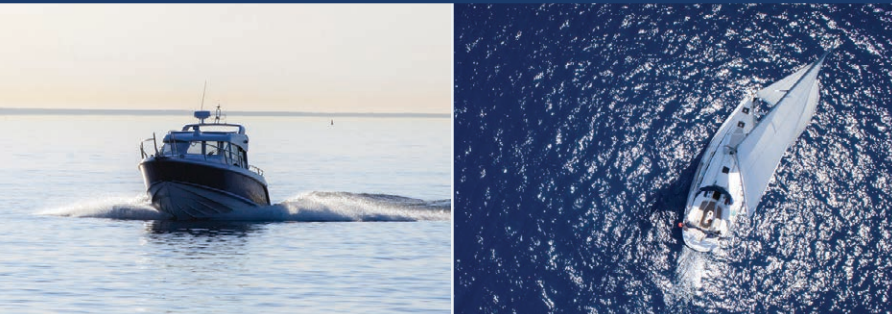

The stainless steel (AISI 316) RC6 automatic rope/chain anchor winch is Maxwell's smallest version in the highly successful vertical RC Series Windlass Range.



RC6 Low Profile



RC6 showing, 'fast install', in-line vertical gearbox and motor

Features and benefits

- The stainless steel (AISI 316) RC6 Series incorporates a chromed bronze chainwheel suitable for use with 6 mm/7 mm (1/4") chain spliced to 12 mm (1/2") three strand or 8-braid (plait) rope
- The RC6 features Maxwell's revolutionary, and patented, Wave Design™ chainwheel. Refer below for more information about this innovative feature
- Providing most of the features of the larger RC8 (refer pages 308 - 309), the RC6 has been designed with the smaller, trailer boat market in mind
- The in-line, vertical gearbox and motor means quick and easy installation by either the boat yard or the DIY aftermarket customer
- An inexpensive, high performance and great looking windlass; the RC6 is built for durability and years of trouble free use
- The RC6 is a Low Profile unit (no optional capstan drum)

STANDARD EQUIPMENT REQUIRED FOR DUAL DIRECTION CONTROL

- Dual Direction Solenoid (included)
- Emergency 'free fall' activation lever (included)
- Up/Down remote control panel (not included)
- Circuit breaker/isolator panel (not included)

OPTIONS

1. AutoAnchor™ Equipment
2. Compact Remote
3. Foot Switches
4. Chain Stopper
5. Chain Snubber

Refer chart on page 340.





Maxwell's smallest version of the rope/chain anchor winch

SPECIFICATIONS

Model	RC6
Maximum Pull/Lift	350 kg / 770 lbs
Static Hold	700 kg / 1540 lbs
Chain Short Link	6 mm/7 mm / 1/4"
Rope Size (Nylon)* (3 strand or 8 plait recommended)	12 mm / 1/2"
Chain Speed (Anchor Retrieval)	24 m/min / 79 ft/min
Rope Speed (Anchor Retrieval)	21 m/min / 69 ft/min
Power Supply (DC)	12 or 24 V
Motor Power	500 W
Net Weight	8.5 kg / 18.7 lb

* Refer to owners manual for rope size variations

DIMENSIONS

Model	RC6
A	196 mm / 7 3/4"
B	80 mm / 3 3/16"
C	145 mm / 5 3/4"
D	209 mm / 8 3/4"
E	65 mm / 2 1/2"
F	39 mm / 1 9/16"

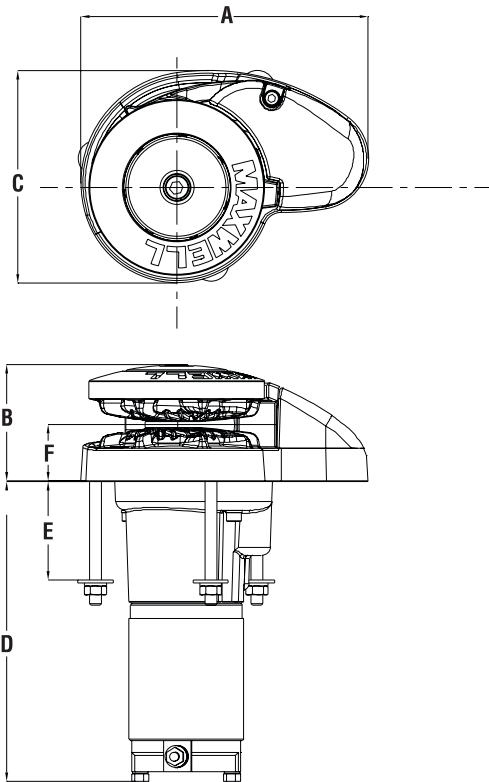

Important: Maxwell windlasses must be used in conjunction with a chain stopper or alternative snubbing device to take the load off the windlass while laying at anchor. The chain stopper and alternative snubbing system should also be used to secure the anchor in the fully raised position while under way.

MAXWELL'S REVOLUTIONARY CHAINWHEEL

Maxwell lead the market yet again in innovative thinking when they introduced the Wave Design™ chainwheel. This patented rope/chain wheel incorporates two unique design concepts that greatly improve the handling and control of the rope/chain spliced rode. The outer ribs of the chainwheel are angled slightly forward ensuring that the rope and the chain are smoothly guided in the wheel during anchor retrieval.

As the rope pulls into the wheel, the opposite facing inner ribs grip the rope in an undulating manner, securing the rope more firmly in a 'wave pattern' action that is far superior to the traditional 'jam cleat' manner of holding the rope compared to all other products on the market. Not only does this Wave Design™ hold the rope more securely, it is also kinder on the rope resulting in increased longevity of your anchor rode.

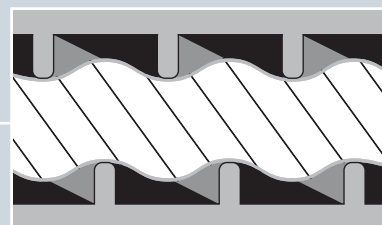



The stainless steel (AISI 316) RC8 Series of automatic rope/chain anchor winches are Maxwell's mid-range models in the highly success RC Series Windlass Range

3 YEAR
Limited Warranty

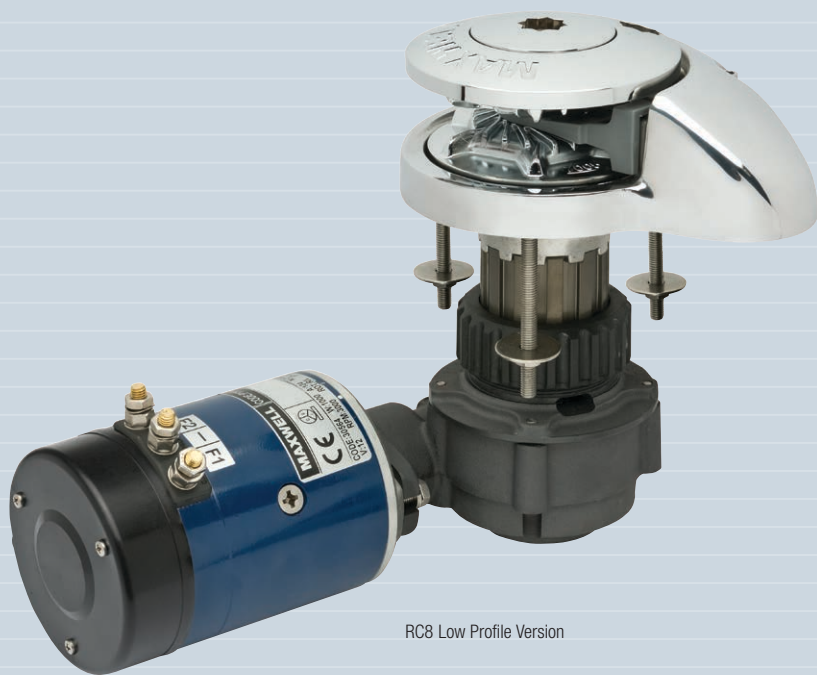

RC8 Low Profile Version

Features and benefits

- The stainless steel (AISI 316) RC8-6 Series incorporates a chromed bronze chainwheel, designed to effortlessly retrieve and deploy 6 mm/7 mm (1/4") chain spliced to 12 mm (1/2") three strand or 8-brait (plait) rope
- The more powerful RC8-8 can be used with 8 mm (5/16") chain spliced to 16 mm (5/8") three strand or 8-plait rope
- The ingenious Wave Design™ rope/chain gypsy (chainwheel) is able to accommodate a wide range of chain pitch differences within the specified chain size diameters suitable for use with the RC8 Series
- A sleek, Low Profile version and a fluted stainless steel capstan drum version, are available
- Simple two piece installation saves time and money and allows easy retrofitting without disassembly of the windlass.
- Unique spacer tube design allows installation through virtually any deck thickness and the multiple mounting positions and self-aligning gearbox ensure optimal location of gearbox and motor in virtually all installation situations
- The RC8 features Maxwell's revolutionary, and patented, Wave Design™ chainwheel. Refer RC6 page 307 for more information about this innovative feature
- The heavy duty stainless steel (AISI 316) pressure arm is designed to effectively help grasp the rope/chain splice, giving the RC8 an unparalleled level of performance. In combination with a heavy duty, large wire diameter, stainless steel pre-loaded spring, the pressure arm always exerts maximum control pressure
- The RC8 works just as effectively with all-chain rodes
- Huge, through deck hawse pipe throat ensures easy entry of the rope/chain rode into and out of the anchor locker
- Full disassembly capability of the topworks utilising only the handle provided and an Allen key
- Manual override and 'Free Fall', using the emergency crank/clutch handle provided
- Sealed oil bath and marine-grade hard anodised, alloy gearbox provides maximum output via a precision worm and worm wheel



RC8 Low Profile Version

SPECIFICATIONS

Model	RC8 (6/7 mm-1/4")	RC8 (8 mm-5/16")
Maximum Pull/Lift	350 kg / 770 lbs	600 kg / 1320 lbs
Static Hold	1200 kg / 2640 lbs	1200 kg / 2640 lbs
Chain Short Link	6/7 mm - 1/4"	8 mm - 5/16"
Rope Size (Nylon)* (3 strand or 8 plait recommended)	12 mm - 1/2"	14 mm/16 mm - 9/16" - 5/8"
Chain Speed (Anchor Retrieval)	28 m/min - 92 ft/min	32 m/min - 105 ft/min
Rope Speed (Anchor Retrieval)	24 m/min - 79 ft/min	28 m/min - 92 ft/min
Power Supply (DC)	12 or 24 V	12 or 24 V
Motor Power	600 W	1000 W
Net Weight	12.5 kg / 27.5 lbs	16.5 kg / 36.3 lbs

* Refer to owners manual for rope size variations

DIMENSIONS

Model	RC8 (6/7 mm-1/4")	RC8 (8 mm-5/16")
A	210 mm / 8 5/16"	210 mm / 8 5/16"
B1	83 mm / 3 5/16"	83 mm / 3 5/16"
B2 (with Capstan)	146 mm / 5 3/4"	146 mm / 5 3/4"
C	156 mm / 6 3/16"	156 mm / 6 3/16"
D	200 mm / 7 7/8"	208 mm / 8 1/4"
E	245 mm / 9 5/8"	272 mm / 10 3/4"
F	383 mm / 15"	410 mm / 16 1/4"
G (Std deck clearance) ^	65 mm / 2 1/2"	65 mm / 2 1/2"
H	40 mm / 1 5/8"	40 mm / 1 5/8"
I	66 mm / 2 5/8"	66 mm / 2 5/8"
J	44 mm / 1 3/4"	44 mm / 1 3/4"

^ extra deck clearance models available. Contact your Maxwell dealer.

Mid-range rope/chain anchor winch

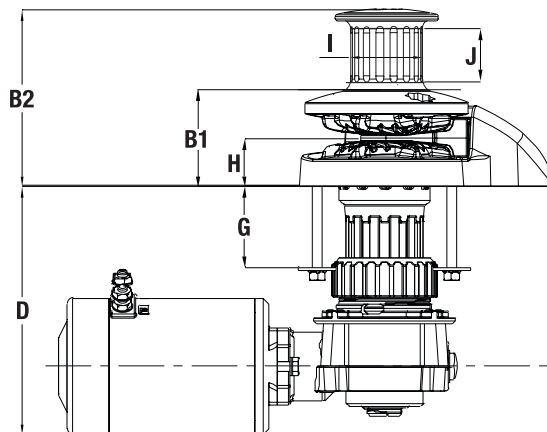
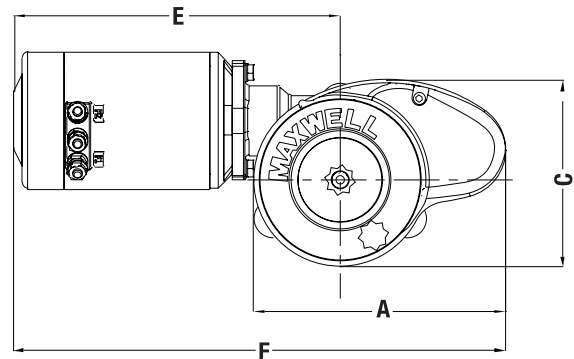

Important: Maxwell windlasses must be used in conjunction with a chain stopper or alternative snubbing device to take the load off the windlass while laying at anchor. The chain stopper and alternative snubbing system should also be used to secure the anchor in the fully raised position while under way.

STANDARD EQUIPMENT REQUIRED FOR DUAL DIRECTION CONTROL

- Dual Direction Solenoid (included)
- Emergency crank/clutch release handle lever (included)
- Up/Down remote control panel (not included)
- Circuit breaker/isolator panel (not included)

Refer chart on page 340.

HEIGHT MATCHED CHAIN STOPPER

- For use with Maxwell's rope/chain vertical windlasses
- Height adjusted to most effectively align chain with the chainwheel
- No height adjustment plinth required
- Refer to page 335 for more information



Height Matched Chain Stopper

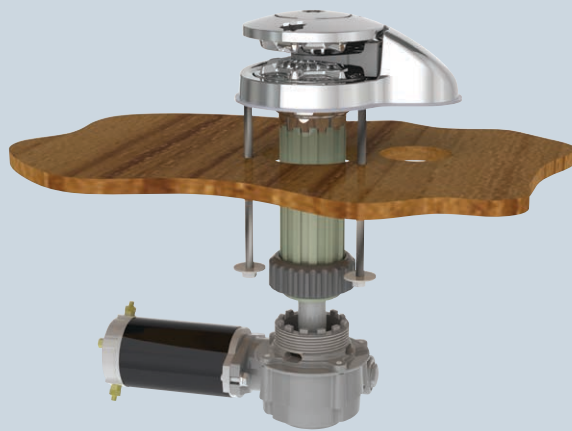

OPTIONS

1. AutoAnchor™ Equipment
2. Compact Remote
3. Foot Switches
4. Chain Stopper
5. Chain Snubber
6. Capstan model





The stainless steel (AISI 316) RC10 Series of automatic rope/chain anchor winches are Maxwell's upper mid-range models in the highly successful RC Series Windlass Range.

Features and benefits

- The stainless steel (AISI 316) RC10-8 Series incorporates a chromed bronze chainwheel, designed to effortlessly retrieve and deploy 8 mm (5/16") chain spliced to 14 mm (9/16") or 16 mm (5/8") three strand or 8-braid (plait) rope
- The more powerful RC10-10 can be use with 10 mm (3/8") chain spliced to 16 mm (5/8") three strand or 8-braid (plait) rope
- A sleek, Low Profile version and a fluted stainless steel capstan drum version, are available
- Simple two piece installation saves time and money and allows easy retrofitting without disassembly of the windlass. Unique spacer tube design allows installation through virtually any deck thickness and the multiple mounting positions and self aligning gearbox ensure optimal location of gearbox and motor in virtually all installation situations
- Full disassembly capability of the topworks utilising only the handle provided and an Allen key
- The RC10 is manufactured from marine-grade 316 stainless steel and chromed bronze for long term durability. The heavy duty stainless steel pressure arm, coupled with the unique rope/chain gypsy, is designed to effectively grasp the splice between rope and chain, giving the RC10 an unparalleled level of performance
- The Heavy Duty Stainless Steel pressure arm combined with a large wire diameter Stainless steel spring ensures consistent pressure on the rode and splice
- The RC10 works just as effectively with all chain rodes for those who desire a Low Profile, elegantly styled windlass on their foredeck
- Huge, through deck hawse pipe throat ensures easy entry of the rope/chain rode into and out of the anchor locker
- Cone type clutch/brake mechanism permits manual, 'Free Fall' anchoring
- Sealed oil bath and marine-grade hard anodised, alloy gearbox provides maximum output via a precision worm and worm wheel



RC10 Capstan Version



RC10 Low Profile Version



SPECIFICATIONS

Model	RC10 (8 mm-5/16")	RC10 (10 mm-3/8")
Maximum Pull/Lift	700 kg 1540 lbs	850 kg 1870 lbs
Static Hold	1500 kg 3300 lbs	1500 kg 3300 lbs
Chain Short Link	8 mm 5/16"	10 mm 3/8"
Rope Size (Nylon)* (3 strand or 8 plait recommended)	14 mm - 16mm 9/16"-5/8"	16 mm 5/8"
Chain Speed (Normal Working load)	24 m/min 79 ft/min	24 m/min 79 ft/min
Rope Speed (Normal Working load)	20 m/min 65 ft/min	20 m/min 65 ft/min
Power Supply (DC)	12 or 24 V	12 or 24 V
Motor (Watts)	1000 W	1200 W
Net Weight	19 kg 42 lbs	20 kg 44 lbs
Hydraulic Pressure	138 bar 2000 PSI	138 bar 2000 PSI
Hydraulic Flow	20 l/min 5.3 USgal/min	20 l/min 5.3 USgal/min
Net Weight - Hydraulic	14 kg/ 42 lbs 26 kg/ 57 lbs	14 kg/ 42 lbs 26 kg/ 57 lbs

* refer to owners manual for rope size variations.

DIMENSIONS

Model	RC10 (8 mm-5/16")	RC10 (10 mm-3/8")
A	230 mm 9 1/8"	230 mm 9 1/8"
B1	89 mm 3 1/2"	89 mm 3 1/2"
B2 (with capstan)	168 mm 6 5/8"	168 mm 6 5/8"
C	170 mm 6 3/4"	170 mm 6 3/4"
D	251 mm 10"	251 mm 10"
E	272 mm 10 3/4"	272 mm 10 3/4"
F	424 mm 16 3/4"	424 mm 16 3/4"
G (Std deck clearance) ^	100 mm 4"	100 mm 4"
H	43 mm 1 3/4"	43 mm 1 3/4"
I	66 mm 2 5/8"	66 mm 2 5/8"
J	44 mm 1 3/4"	44 mm 1 3/4"

^ extra deck clearance models available. Contact your Maxwell dealer.

HEIGHT MATCHED CHAIN STOPPER

- For use with Maxwell's rope/chain vertical windlasses
- Height adjusted to most effectively align chain with the chainwheel
- No height adjustment plinth required
- Refer to page 335 for more information



Height Matched Chain Stopper

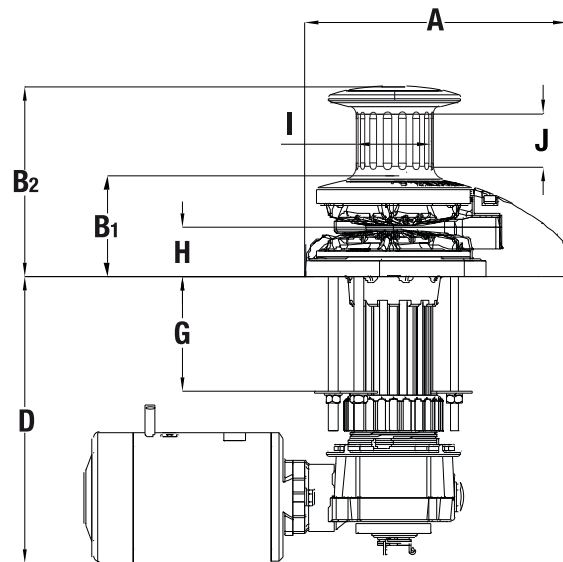
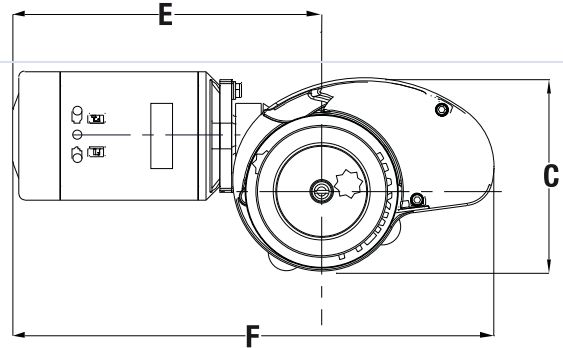

Important: Maxwell windlasses must be used in conjunction with a chain stopper or alternative snubbing device to take the load off the windlass while laying at anchor. The chain stopper and alternative snubbing system should also be used to secure the anchor in the fully raised position while under way.

STANDARD EQUIPMENT REQUIRED FOR DUAL DIRECTION CONTROL

- Dual Direction Solenoid (included)
- Emergency crank/clutch release handle lever (included)
- Up/Down remote control panel (not included)
- Circuit breaker/isolator panel (not included)

OPTIONS

1. AutoAnchor™ Equipment
2. Compact Remote
3. Foot Switches
4. Chain Stopper
5. Chain Snubber
6. Capstan model

Refer chart on page 340.





The RC12 Series incorporates Maxwell's latest stylish innovation in automatic rope/chain windlass technology. Retaining the classic open design styling more appropriate on larger boats, the RC12-10 and RC12-12 represent the next generation of rope/chain windlass evolution in every respect.



RC12 Capstan Model

3 YEAR
Limited Warranty

Activation of the ratcheted mechanism lever ensures the windlass cannot backwind during emergency (manual) retrieval of the rode (rope and/or chain) and anchor.



Features and benefits

- The RC12 fully automatic windlass series is designed to effortlessly retrieve and deploy 10 mm (3/8") short link chain and 16 mm (5/8") to 20 mm (3/4") three strand or 8-Plait rope (RC12-10) and 13 mm (1/2") short link chain and 16 mm (5/8") to 20 mm (3/4") three strand or 8-Plait rope (RC12-12)
- Stainless steel AISI 316
- With a maximum pull of 1590 kg (3500 lb), and an anchor retrieval rate of 15 m/min (50ft/min), the RC12-12 is one of the fastest and gruntest windlasses in its class
- A sleek, Low Profile version and a fluted stainless steel (AISI 316) capstan drum version, are available
- The RC12 is packed with patented innovative features combined with Maxwell's traditionally classic aesthetics, but reflecting the modern "form follows function" of the highly successful RC6, RC8 and RC10 series windlasses
- The elegantly designed deckplate and chainpipe cover are manufactured in polished marine-grade (AISI 316) stainless steel, as are the heavy duty pressure arm, stripper, chainwheel and fluted capstan drum
- The huge, through deck hawse pipe throat ensures easy entry of the rope/chain rode into and out of the anchor locker
- Double cone-type brake/clutch mechanism permits 'Free Fall' anchoring. Cone clutches, unlike dog clutches, provide smooth progressive engagement, ensuring safe and precise operator control
- The RC12 features Maxwell's revolutionary and patented Wave Design™ chainwheel. Refer to RC6 page 307 for more information about this innovative feature
- Emergency manual retrieval is made simple and easy with Maxwell's unique "Active Latch Ratchet System" operation that prevents backwind of the windlass during manual hauling of the anchor
- The Maxwell designed, all new and innovative black, hard anodised gearbox provides numerous advantages:
 - Fast and easy windlass installation
 - More corrosion resistant
 - Easy to maintain and service
 - Takes up less room in the anchor locker
 - 75:1 Ratio (RC12-10) or 100:1 Ratio (RC12-12), single stage design with less moving parts, for smoother and quieter operation
 - Allows for multi-positioning of the gearbox/motor

SPECIFICATIONS

Model	RC12 (10/11 mm-3/8")	RC12 (12/13 mm-1/2")
Maximum Pull/Lift	1134 kg 2500 lbs	1590 kg 3500 lbs
Static Hold	2200 kg 4840 lbs	2200 kg 4840 lbs
Chain Short Link**	10/11 mm 3/8"	12/13 mm 1/2"
Rope Size (Nylon)** (3 strand or 8 plait recommended)	16-20 mm 5/8-3/4"	20-22 mm 3/4"
Chain Speed (at normal working load)	20 m/min 65 ft/min	15 m/min 50 ft/min
Rope Speed (at normal working load)	17 m/min 56 ft/min	13 m/min 43 ft/min
Power Supply (DC)	12 or 24 V	12 or 24 V
Motor Power	1200 W	1200 W
Net Weight - DC (Capstan version)	32 kg 71 lbs	32 kg 71 lbs
Net Weight - DC (Low Profile version)	29 kg 64 lbs	29 kg 64 lbs
Hydraulic Pressure	138 bar 2000 PSI	138 bar 2000 PSI
Hydraulic Flow	42 l/min 11 USgal/min	42 l/min 11 USgal/min
Net Weight - Hyd (Low Profile)	23 kg/ 51 lbs	23 kg/ 51 lbs
(Capstan version)	26 kg/ 57 lbs	26 kg/ 57 lbs

** When ordering please specify your specific rope and chain, combination rope

DIMENSIONS

Model	RC12 (10 mm-3/8")	RC12 (12/13 mm-1/2")
A	293 mm 11 5/8"	293 mm 11 5/8"
B ¹ (Low Profile version)	128 mm 5 1/8"	128 mm 5 1/8"
B ² (Capstan version)	233 mm 9 1/4"	233 mm 9 1/4"
C	206 mm 8 1/8"	206 mm 8 1/8"
D (Std deck clearance)	210 mm 8 3/8"	210 mm 8 3/8"
E	294 mm 11 5/8"	294 mm 11 5/8"
F	482 mm 19"	482 mm 19"
G (Std deck clearance)	90 mm 3 5/8"	90 mm 3 5/8"
H	54 mm 2 1/4"	54 mm 2 1/4"
I	106 mm 4 1/4"	106 mm 4 1/4"
J	62 mm 2 1/2"	62 mm 2 1/2"

Stylish innovation in automatic rope/chain windlass technology

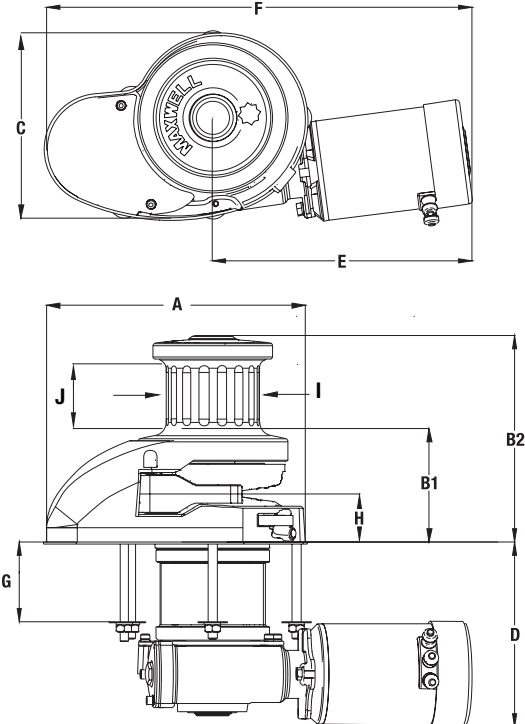

RC12 Low Profile Model

Important: Maxwell windlasses must be used in conjunction with a chain stopper or alternative snubbing device to take the load off the windlass while laying at anchor. The chain stopper and alternative snubbing system should also be used to secure the anchor in the fully raised position while under way.

STANDARD EQUIPMENT REQUIRED FOR DUAL DIRECTION CONTROL

Dual Direction Solenoid (included)
Emergency (manual) retrieval handle (included)
Clutch release handle (included)
Up/Down remote control panel (not included)
Circuit breaker/isolator panel (not included)

OPTIONS

1. AutoAnchor™ Equipment
2. Compact Remote
3. Foot Switches
4. Chain Stopper
5. Chain Snubber
6. Capstan model

HEIGHT MATCHED CHAIN STOPPER

- For use with Maxwell's rope/chain vertical windlasses
- Height adjusted to most effectively align chain with the chainwheel
- No height adjustment plinth required
- Refer to page 335 for more information



Height Matched Chain Stopper

Refer chart on page 340.





Heavy Duty Rope/Chain Series



RC12HD Capstan Version

- The RC12HD is designed for use with 10 to 13 mm (3/8" to 1/2") short link chain combined with 18 to 24 mm (3/4" to 7/8") nylon rope
- The motor and gearbox are sized to meet typical Classification Society test requirements for 12.5 mm U1 grade chain
- This design is particularly well suited to light duty commercial vessels requiring high service speeds, e.g. patrol vessels, as the reduced weight of the rope/chain combination removes weight from the bow
- The 38 mm (1½") mainshaft is manufactured in high strength corrosion resistant 2205 Duplex stainless steel and the above deck components in AISI 316 stainless steel providing excellent corrosion resistance and highly polished finish
- The RC12HD is available with either a Heavy duty fan cooled 24VDC, 3 phase AC, Hydraulic motors of various displacements or single phase AC motor (contact your distributor for specifications and application). Run time and continuous pull varies between versions (see specifications on the following page)
- Double cone-type brake/clutch mechanism permits 'Free Fall' anchoring. Cone clutches, unlike dog clutches, provide smooth progressive engagement, ensuring safe and precise operator control
- The RC12HD features Maxwell's revolutionary and patented Wave Design™ chainwheel

Important: Maxwell windlasses must be used in conjunction with a chain stopper or alternative snubbing device to take the load off the windlass while laying at anchor. The chain stopper and alternative snubbing system should also be used to secure the anchor in the fully raised position while under way.

3 YEAR
Limited Warranty



RC12HD Low Profile Model

SPECIFICATIONS

	24V DC Electric (2000W)	Hydraulic	AC Electric
Maximum pull	1820 kg (4000 lbs)	1200 kg (2640 lbs)	1820 kg (4000 lbs)
Continuous pull	300 kg (660 lbs)	1200 kg (2640 lbs)	620 kg (1360 lbs)
Line speed at continuous pull	12 m/min (39 ft/min)	15 m/min (49 ft/min)	12 m/min (39 ft/min)
Working Load limit (10 min)	610 kg (1335 lbs)	1200 kg (2640 lbs)	750 kg (1650 lbs)
Maximum line speed	18 m/min (59 ft/min)	15 m/min (49 ft/min)	12 m/min (39 ft/min)
Static Hold	2200 kg (4840 lbs)	2200 kg (4840 lbs)	2200 kg (4840 lbs)
Net Weight (Capstan Version)	40 kg (88 lbs)	31.5 kg (69 lbs)	54 kg (118 lbs)
Power Supply	24V DC	Hydraulic	3Ph AC
Motor Power	2000 W	N/A	2200 W
Maximum Hydraulic Pressure	N/A	138 Bar (2000 PSI)	N/A
Recommended Hydraulic Flow	N/A	40 l/min (11 Gal/min)	N/A

Accessories	Code	Voltage
Reversing Solenoid	SP5107	24V
Circuit Breaker	P100791	135 Amp

Refer to page numbers 330 - 333 for additional electrical accessories.

DIMENSIONS

	Hydraulic Type 2	Hydraulic Type 1	24V DC Electric	3phase AC Electric
A	293 mm 11 5/8"	293 mm 11 5/8"	293 mm 11 5/8"	293 mm 11 5/8"
B ¹ (Low Profile version)	128 mm 5 1/8"	128 mm 5 1/8"	128 mm 5 1/8"	128 mm 5 1/8"
B ² (Capstan version)	233 mm 9 1/4"	233 mm 9 1/4"	233 mm 9 1/4"	233 mm 9 1/4"
C	206 mm 8 1/8"	206 mm 8 1/8"	206 mm 8 1/8"	206 mm 8 1/8"
D	241 mm 9 1/2"	243 mm 9 9/16"	241 mm 9 1/2"	270 mm 10 5/8"
E	218 mm 8 5/8"	228 mm 9"	361 mm 14 1/4"	423 mm 16 5/8"
F	406 mm 16"	416 mm 16 3/8"	549 mm 21 5/8"	611 mm 24"
G	95 mm 3 3/4"	95 mm 3 3/4"	95 mm 3 3/4"	69 mm 2 3/4"
H	54 mm 2 1/4"	54 mm 2 1/4"	54 mm 2 1/4"	54 mm 2 1/4"
I	134 mm 5 1/4"	156 mm 6 1/8"	139 mm 5 1/2"	175 mm 6 7/8"

Extra Deck Clearance available, add 100m to dimensions D & G.

Hydraulic (Motor Type 2)

Hydraulic GT (Motor Type 1)

24V DC Electric

AC 3Phase Electric

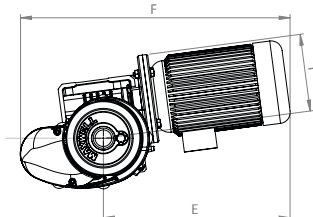
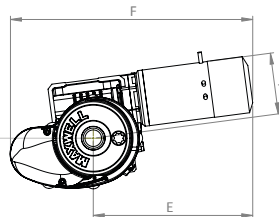
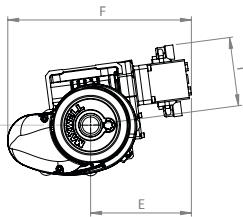
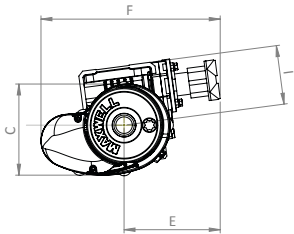

Low Profile Versions

Capstan Versions

Low Profile Versions

Capstan Versions

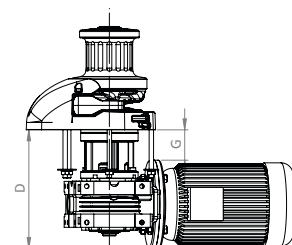
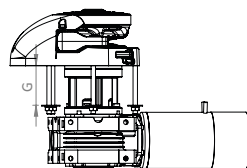
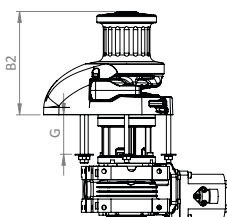
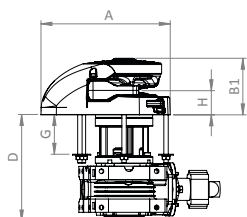



VC500



An extremely versatile capstan

ANCHORMAX™

An extremely versatile vertical capstan or general purpose electric winch for use as an anchor winch, pot hauler or davit winch.

The ANCHORMAX™ has an extremely high power to weight ratio. The compact, fully sealed gearbox is driven by a vertically mounted, permanent magnet motor. Intrusion below decks is minimised making the design ideal for boats from 5 metres (16ft) to 10 metres (32ft). Fitting to the boat is simplicity itself as no dismantling of the winch is required.

The ANCHORMAX™ gear housings are marine-grade alloy and the drum is stainless steel (AISI 316). It is supplied as a single direction (clockwise) unit, complete with deck foot switch, fastenings, template and fitting instructions.

The ANCHORMAX™ is not recommended for use to haul halyards.



All standard and optional control accessories can be found on pages 330 - 333.

3 YEAR
Limited Warranty

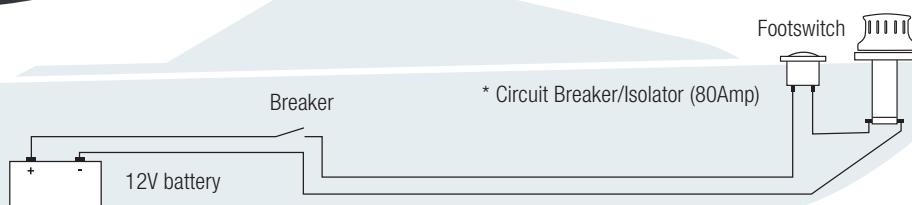

*Not supplied with but recommended

ANCHORMAX SPECIFICATIONS

Maximum Line Pull/Lift	330 kg (740 lbs)
Speed @ nominal working load	32 m/min
(80 Amps with 75 kg/165 lb load)	(105' per min)
Voltage	12 V
Power	500 W
Weight	5.5 kg (17.6 lbs)
Maximum Boat LOA	10 m (33')
Maximum Boat Weight	4 tonnes

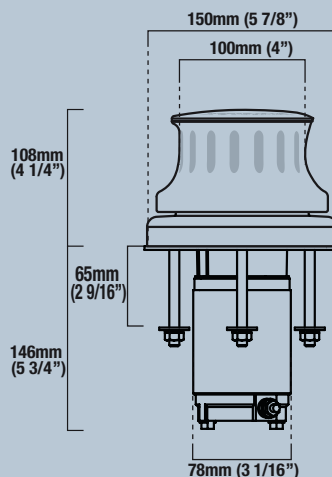

High quality fluted capstan for smaller (power/sail) boats

The stainless steel (AISI 316) fluted capstan VC Series is designed for simple, low cost anchor recovery on smaller boats and rope hauling on larger vessels.

Features and benefits

- Vertical design suits smaller powerboats or sailboats and can be utilised for anchor rodes, as a docking capstan on larger craft, or auxiliary line hauling from any direction
- High quality, hard wearing stainless steel (AISI 316) above deck components
- Functional rope hauling from any direction using fluted, snag-free warping drum for positive control of all ropes
- Simplified through deck installation by modular design and precise alignment of gearbox to the topworks
- Alternative gearbox/motor positions accommodate virtually all installation situations
- Compact, reliable gearbox, made of corrosion resistant materials
- Anodized aluminium gearbox and spacer on VC500 and VC1000 models
- Heavy duty, dual direction motors, designed for marine winches
- Easily disassembled for servicing
- Can be mounted horizontally for use as a pot hauler or davit winch

STANDARD EQUIPMENT REQUIRED FOR SINGLE DIRECTION CONTROL

Circuit breaker/isolator panel (not included)
Foot Switch (included)

OPTIONS

Extra deck clearance
Hydraulic motor*



VC500

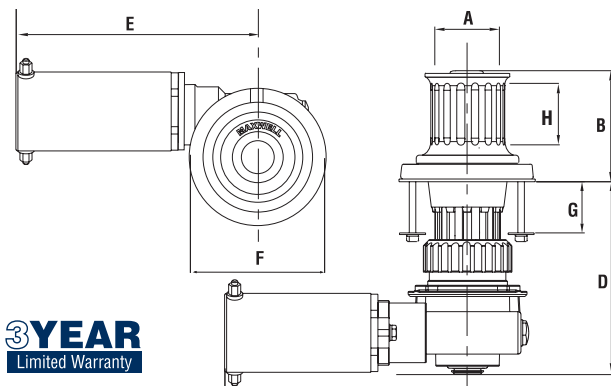

SPECIFICATIONS

Model	500	1000
Maximum Pull/Lift	300 kg 660 lbs	700 kg 1540 lbs
Static Hold	N/A N/A	N/A N/A
Line Speed (Normal Working)	18 m/min 60 ft/min	20 m/min 65 ft/min
Power Supply (DC)	12 or 24 V	12 or 24 V
Motor (Watts)	600 W	1000 W
Net Weight (Electric)	10 kg 22 lbs	18 kg 40 lbs
Hydraulic Pressure	*N/A *N/A	100 bar 1450 psi
Hydraulic Flow	*N/A *N/A	20 l/min 5.3 USgal/min
Net Weight - Hyd	*N/A *N/A	11 kg 24 lbs

DIMENSIONS

Model	500	1000
A	65 mm 2 9/16"	80 mm 3 1/8"
B	106 mm 4 3/16"	122.5 mm 4 5/6"
D (Std deck clearance)	173 mm 6 7/8"	252 mm 9 15/16"
E	245 mm 9 5/8"	272 mm 10 3/4"
F	132.5 mm 5 7/32"	160 mm 6 5/16"
G (Std deck clearance) OR**	57 mm 2 1/4"	100 mm 4"
G (Extra deck clearance) ^	N/A N/A	150 mm 6"
H	37.5 mm 1 7/16"	44 mm 1 3/4"

**For VC1000 a shorter deck clearance version is also available at 50 mm (2")

^ A deck clearance increase will also increase the 'D' measurement by the same increment.

All standard and optional control accessories can be found on pages 330 - 333.





The VW Series of anchor winches are designed for traditional rope and chain combination anchor rodes, where manual transfer of the rode from the rope warping drum to the chainwheel is required.



3 YEAR
Limited Warranty

VW10 Capstan Version



Features and benefits

- Provides the versatility of operating two anchors from one winch
- Functional rope hauling from any direction using independent MAX-grip™ snag-free warping drum with clutch disengagement of chainwheel for positive control of all ropes
- Permits use of traditional shackle and thimble rope and chain connection
- Allows alternative mounting horizontally on a fore and aft bulkhead inside chain locker for below deck installation
- High-quality finish on above deck components, manufactured from marine grade stainless steel (AISI 316) and chromed bronze, for long term durability
- Cone type brake/clutch mechanism permits manual 'Free Fall' anchoring. Cone clutches, unlike dog clutches, provide smooth progressive engagement ensuring safe operator control
- Chainwheel locking pawl (except on VW500 and VW10)
- Simplified through deck installation by modular design and precise alignment of gearbox to the topworks utilising marine-grade stainless steel (AISI 316) bolts
- Anodized aluminium gearbox and spacertube
- Heavy duty, dual direction motor, designed for marine winches
- Easily disassembled for servicing

VW10 WINDLASS FOR USE WITH SPLICED ROPE/CHAIN

The VW10 evolved from the demand for a vertical windlass that could be used in a horizontally installed configuration (refer image above), but which would also, interactively handle a rope/chain rode. The chainwheels on traditional VW models could be used with chain only rodes. The VW10, capable of automatically handling up to 10 mm (3/8") chain and 16 mm (5/8") rope, is ideally suited for use in sailing boat anchor lockers, where space considerations are critical. Quick and easy to install and available with or without independent warping capstan, the VW10 is destined to become an instant hit in this unique niche market.

STANDARD EQUIPMENT REQUIRED FOR SINGLE DIRECTION CONTROL

- Dual Direction Solenoid (included)
- Emergency crank handle/clutch control lever (included, except with VW500)
- Chainwheel to suit chain specified chain size (included)
- Circuit breaker/isolator panel (not included)
- Windlass electrical controls (not included)

OPTIONS

1. AutoAnchor™ Equipment
2. Foot Switches
3. Chain Stopper*
4. Chain Snubber
5. Extra deck clearance kit
6. Hydraulic motor (except on 500)
7. Up/Down remote control panel
8. Circuit breaker/isolator panel

All standard and optional control accessories can be found on pages 330 - 333.

Ideal for use in sailing boat anchor lockers with little available space

SPECIFICATIONS

MODEL	500	VW10-8 8 mm (5/16")	VW10-10 10 mm (3/8")	1000	1500	2500	3500
Maximum Pull/Lift	227 kg 500 lbs	700 kg 1540 lbs	850 kg 1870 lbs	700 kg 1540 lbs	850 kg 1870 lbs	1135 kg 2500 lbs	1590 kg 3500 lbs
Static Hold	600 kg 1320 lbs	1500 kg 3300 lbs	1500 kg 3300 lbs	1500 kg 3300 lbs	1500 kg 3300 lbs	2200kg 4840lbs	2200 kg 4840 lbs
Chain Short Link	6/7 mm 1/4"	8 mm 5/16"	10 mm 3/8"	6-10 mm 1/4" -3/8"	6-10 mm 1/4" -3/8"	9-11 mm 5/16"-3/8"	10-13 mm 3/8"-1/2"
Line Speed**	18 m/min (Normal Working) 59 ft/min	24 m/min 79 ft/min	24 m/min 79 ft/min	18 m/min 59 ft/min	18 m/min 59 ft/min	15 m/min 50 ft/min	15 m/min 50 ft/min
Power Supply (DC)	12 or 24 V	12 or 24 V	12 or 24 V	12 or 24 V	12 or 24 V	12 or 24 V	12 or 24 V
Motor (Watts)	600 W	1000 W	1200 W	1000 W	1200 W	1200 W	1200 W
Net Weight	10 kg (Electric) 22 lbs	19 kg 42 lbs	20 kg 44 lbs	22 kg 50 lbs	22 kg 50 lbs	38 kg 84 lbs	48 kg 105 lbs
Hydraulic	N/A	N/A	N/A	100 bar	138 bar	138 bar	138 bar
Pressure	N/A	N/A	N/A	1450 psi	2000 psi	2000 psi	2000 psi
Hydraulic Flow	N/A	N/A	N/A	20 l/min 5.3USgal/ min	20 l/min 5.3USgal/ min	36 l/min 9.5USgal/ min	42 l/min 11USgal/ min
Net Weight (Hyd)	N/A	N/A	N/A	15 kg 34 lbs	15 kg 34 lbs	32 kg 70 lbs	40 kg 88 lbs

** Winch performance when hauling rope with capstan. Chain speed may vary depending on size of chain and gypsy.

DIMENSIONS

MODEL	500	VW10-8	VW10-10	1000	1500	2500	3500
A	65 mm 2 9/16"	66 mm 2 5/8"	66 mm 2 5/8"	80 mm 3 1/8"	80 mm 3 1/8"	94 mm 3 11/16"	110 mm 4 5/16"
B	151 mm 6"	168 mm 6 5/8"	168 mm 6 5/8"	198 mm 7 3/4"	198 mm 7 3/4"	251 mm 9 15/16"	276 mm 10 7/8"
C	40 mm 1 5/8"	43 mm 1 3/4"	43 mm 1 3/4"	59 mm 2 3/8"	59 mm 2 3/8"	80 mm 3 5/32"	83 mm 3 9/32"
D	173 mm 6 7/8"	252 mm 10"	252 mm 10"	252 mm 10"	252 mm 10"	219 mm 8 5/8"	219 mm 8 5/8"
E	244 mm 9 5/8"	272 mm 10 3/4"	272 mm 10 3/4"	272 mm 10 3/4"	272 mm 10 3/4"	281 mm 11 1/8"	281 mm 11 1/8"
F	133 mm 5 1/4"	172 mm 6 7/8"	172 mm 6 7/8"	165 mm 6 1/2"	165 mm 6 1/2"	190 mm 7 1/2"	270 mm 10 5/8"
G (Std deck clearance)**	57 mm 2 1/4"	100 mm 4"	100 mm 4"	100 mm 4"	100 mm 4"	85 mm 3 11/32"	85 mm 3 11/32"
G (Extra deck clearance) ^	N/A	150 mm 6"	150 mm 6"	150 mm 6"	150 mm 6"	190 mm 7 1/2"	190 mm 7 1/2"
H (Working height of drum for rope warping)	37.5 mm 1 1/2"	44 mm 1 3/4"	44 mm 1 3/4"	44 mm 1 3/4"	44 mm 1 3/4"	33 mm 1 5/16"	54 mm 2 1/8"
I	133 mm 5 1/4"	140 mm 5 5/8"	140 mm 5 5/8"	165 mm 6 1/2"	165 mm 6 1/2"	194 mm 7 5/8"	270 mm 10 5/8"

**For VW1000 and VW1500 shorter deck clearance version also available at 50 mm (2")

^ A deck clearance increase will also increase the 'D' measurement by the same increment.

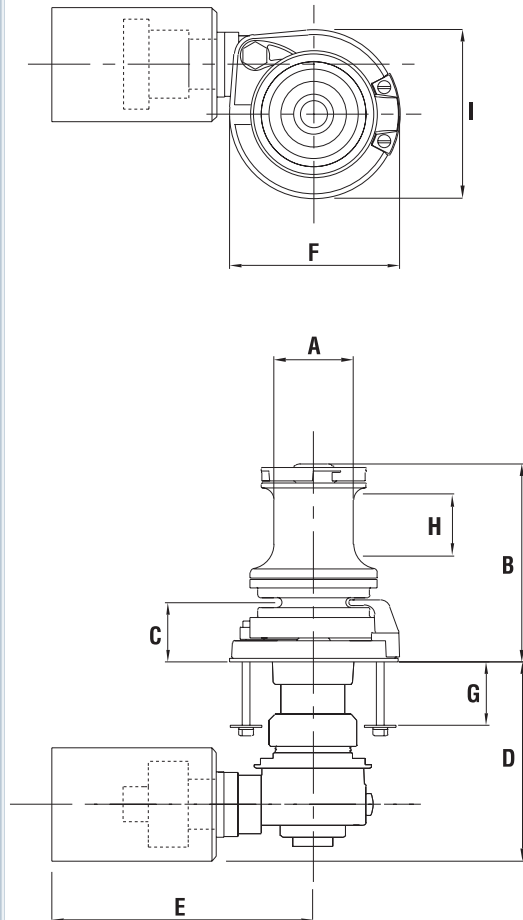

1500 VWLP

Important: Maxwell windlasses must be used in conjunction with a chain stopper or alternative snubbing device to take the load off the windlass while laying at anchor. The chain stopper and alternative snubbing system should also be used to secure the anchor in the fully raised position.





The VWC Series is designed for automatic vertical handling of chain-only anchor rodes while offering an independent capstan for the retrieval of a secondary rope and chain rode or to assist with docking procedures.

Features and benefits

- Fully automatic single or dual direction chainwheel operation
- High-quality finish on above deck components, manufactured from marine grade stainless steel (AISI 316), for long term durability
- Integral chain pipe and stripper are aligned for virtually jam-free operation providing automatic feed of chain into and out of the anchor locker
- Port and starboard chain pipes for twin installations (Sizes 2500 and above only)
- Cone-type brake/clutch mechanism permits manual 'free fall' anchoring. Cone clutches, unlike dog clutches, provide smooth progressive engagement ensuring safe and precise operator control
- Chainwheel locking pawl
- Optional Band Brake available for 3500 series unit
- Clutch disengagement of the chainwheel enables independent rope hauling from any direction, using the Max-grip™ snag-free warping drum for positive control of all ropes
- Simple through deck installation by modular design and precise alignment of gearbox to the topworks utilising marine-grade stainless steel bolts
- Anodized aluminium gearbox and spacer tube on all models.
- Heavy duty, dual direction motor, designed for marine winches
- Low Profile configurations (no warping drum) are available



3 YEAR
Limited Warranty

STANDARD EQUIPMENT REQUIRED FOR DUAL DIRECTION CONTROL

Dual Direction Solenoid (included)
Emergency crank handle/clutch control lever (included)
Chainwheel to suit chain specified chain size (included)
Up/Down remote control panel (not included)
Circuit breaker/isolator panel (not included)

OPTIONS

1. AutoAnchor™ Equipment
2. Foot Switches
3. Chain Stopper*
4. Up/Down remote control panel
5. Extra deck clearance kit
6. Hydraulic motor
7. Compact Remote
8. Roving remote

All standard and optional control accessories can be found on pages 330 - 333.

VWC2500



Important: Maxwell windlasses must be used in conjunction with a chain stopper or alternative snubbing device to take the load off the windlass while laying at anchor. The chain stopper and alternative snubbing system should also be used to secure the anchor in the fully raised position while under way.

Fully automatic operation for chain-only installations

SPECIFICATIONS

MODEL	1000	1500	2500	3500
Maximum Pull/Lift	700 kg 1540 lbs	850 kg 1870 lbs	1135 kg 2500 lbs	1590 kg 3500 lbs
Static Hold	1500 kg 3300 lbs	1500 kg 3300 lbs	2200 kg 4840 lbs	2200 kg 4840 lbs
Chain Short Link	6-10 mm 1/4" - 3/8"	6-10 mm 1/4" - 3/8"	9-11mm 5/16" - 7/16"	10-13 mm 3/8" - 1/2"
Line Speed (Normal Working)	18m/min 60 ft/min	18 m/min 60 ft/min	15 m/min 50 ft/min	15 m/min 50 ft/min
Power Supply (DC)	12 or 24 V	12 or 24 V	12 or 24 V	12 or 24 V
Motor (Watts)	1000 W	1200 W	1200 W	1200 W
Net Weight - DC	24 kg 52 lbs	24 kg 52 lbs	38 kg 84 lbs	48 kg 106 lbs
Hydraulic Pressure	100 bar 1450 PSI	138 bar 2000 PSI	138 bar 2000 PSI	138 bar 2000 PSI
Hydraulic Flow	20 l/min 5.3 USgal/min	20 l/min 5.3 USgal/min	36 l/min 9.5 USgal/min	42 l/min 11US gal/min
Net Weight - Hyd	17 kg 37 lbs	17 kg 37 lbs	32 kg 70 lbs	40 kg 88 lbs

DIMENSIONS

MODEL	1000	1500	2500	3500
A	80 mm 3 1/8"	80 mm 3 1/8"	94 mm 3 11/16"	110 mm 4 5/16"
B	195 mm 7 11/16"	195 mm 7 11/16"	242 mm 9 9/16"	254 mm 10"
B ¹ (Low Profile)	98 mm 3 7/8"	98 mm 3 7/8"	148 mm 5 27/32"	149 mm 5 7/8"
C	56 mm 2 7/32"	56 mm 2 7/32"	80 mm 3 5/32"	83 mm 3 9/32"
D	252 mm 9 5/16"	252 mm 9 5/16"	219 mm 8 5/8"	219 mm 8 5/8"
E	262 mm 10 11/32"	272 mm 10 23/32"	281 mm 11 1/8"	281 mm 11 1/8"
F	224 mm 8 27/32"	224 mm 8 27/32"	297 mm 11 23/32"	342 mm 13 7/16"
G (Std deck clearance)*	100 mm 4"	100 mm 3 11/32"	85 mm 3 11/32"	100 mm 4"
G (Extra deck clearance)^	150 mm 6"	150 mm 6"	190 mm 7 1/2"	190 mm 7 1/2"
H (Working height of drum for rope warping)	44 mm 1 3/4"	44 mm 1 3/4"	33 mm 1 5/16"	29 mm 1 1/8"
I	165 mm 6 1/2"	165 mm 6 1/2"	190 mm 7 1/2"	215 mm 8 15/32"

*For WVC1000 and WVC1500 a shorter deck clearance version is also available at 50 mm (2").

^ A deck clearance increase will also increase the 'D' measurement by the same increment.

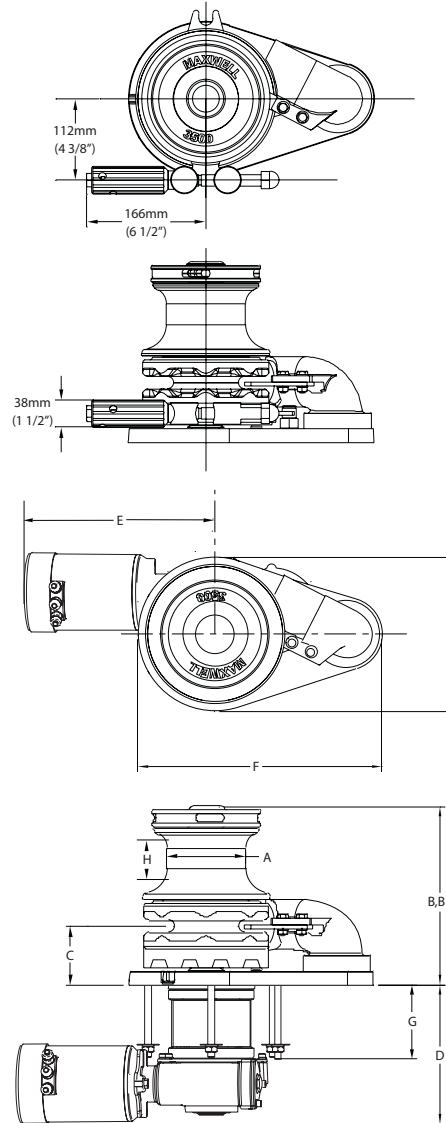

WVC3500 Band Brake featuring Maxwell's innovative 'stow-a-way' tensioning lever



WVC3500 without Band Brake





The sleek, compact HRCFF 6-7-8 are Maxwell's horizontal versions of the latest innovative vertical RC6 and RC8 automatic rope/chain windlasses. The HRCFF Series are packed with original and proven features including patented rode management technology developed by Maxwell.

Features and benefits

- Now incorporating Maxwell's automatic free-fall technology. Simply activate the windlass 'Free Fall' lever, operate your down control (helm station or footswitch) and the windlass will freefall your anchor. Ready to lift the anchor? Activate the up control and the 'free fall' device automatically disengages allowing you to power up your anchor
- Aesthetically pleasing above deck design, encapsulating the motor and drive in a watertight case, saving space below deck and allowing simple routine maintenance
- Die cast, marine-grade, alloy case is hard anodized for unsurpassed marine protection
- Simple 'bolt down' installation ensures effortless and rapid on-deck installation and set up
- Trouble free rode transition from rope to chain, by means of an innovative, proven and patented pressure arm system, within a safe enclosed design
- Integrated composite nylon, through deck hawse pipe for ease of installation and smooth, snag-free operation
- High efficiency spur gearbox incorporating a robust non-backwind mechanism
- High speed, jam-free retrieval of rope and chain controlled from a remote panel mounted Up/Down switch
- Emergency 'free fall' function in the event of onboard power failure. Activated by the supplied, emergency 'Free Fall' lever
- Revolutionary Wave Design™ chainwheel - see next page
- Heavy duty, dual direction motor incorporating new technology features, including integrated wiring for quick electrical installation



HRCFF

3 YEAR
Limited Warranty



STANDARD EQUIPMENT REQUIRED FOR DUAL DIRECTION CONTROL

Dual Direction Solenoid (included)
Clutch Release Handle (included)
Up/Down remote control panel (not included)
Circuit breaker panel (not included)

Refer chart on page 340.

OPTIONS

1. AutoAnchor™ Equipment
2. Compact Remote
3. Foot Switches
4. Chain Stopper
5. Chain Snubber

Important: Maxwell windlasses must be used in conjunction with a chain stopper or alternative snubbing device to take the load off the windlass while laying at anchor. The chain stopper and alternative snubbing system should also be used to secure the anchor in the fully raised position while under way.

3 YEAR
Limited Warranty

Compact horizontal automatic rope/chain windlass

SPECIFICATIONS

Model	HRCFF6	HRCFF7	HRCFF8
Maximum Pull/Lift	410 kg 900 lbs	410 kg 900 lbs	410 kg 900 lbs
Static Hold	700 kg 1540 lbs	700 kg 1540 lbs	700 kg 1540 lbs
Chain Short Link	6 mm	7 mm 1/4"	8 mm 5/16"
Rope Size (Nylon)* (3 strand or 8 plait recommended)	12 mm 1/2"	12 mm 1/2"	14 mm 9/16"
Line Speed (Anchor Retrieval)	33 m/min	33 m/min	33 m/min
Nominal 30kg working load	108 ft/min	108 ft/min	108 ft/min
Power Supply (DC)	12 V	12 V	12 or 24 V
Motor Power	600 W	600 W	600 W
Net Weight	11.5 kg 25 lbs	11.5 kg 25 lbs	11.5 kg 25 lbs

*refer to owners manual for rope size variations.

DIMENSIONS

All Models	mm	inches
A	256	10 1/8
B	132	5 11/32
B ²	176	6 7/8
C ¹	214	8 7/16
C ²	147	5 3/4
E	65	2 1/2
G	230	9 1/16
J	96.4	3 7/8

All standard and optional control accessories can be found on pages 330 - 333.

MAXWELL'S REVOLUTIONARY CHAINWHEEL

Maxwell lead the market yet again in innovative thinking when they introduced the Wave Design™ chainwheel. This patented rope/chain wheel incorporates two unique design concepts that greatly improve the handling and control of the rope/chain spliced rode.

The outer ribs of the chainwheel are angled slightly forward ensuring that the rope and the chain are smoothly guided in the wheel during anchor retrieval. As the rope pulls into the wheel, the opposite facing inner ribs grip the rope in an undulating manner, securing the rope more firmly in a 'wave pattern' action that is far superior to the traditional 'jam cleat' manner of holding the rope compared to all other products on the market. Not only does this Wave Design™ hold the rope more securely, it is also kinder on the rope resulting in increased longevity of your anchor rode.

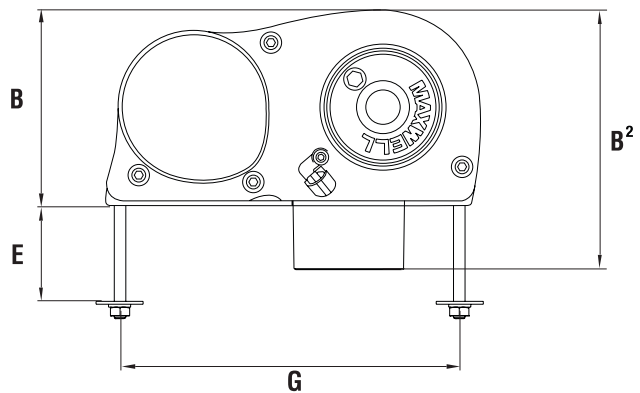
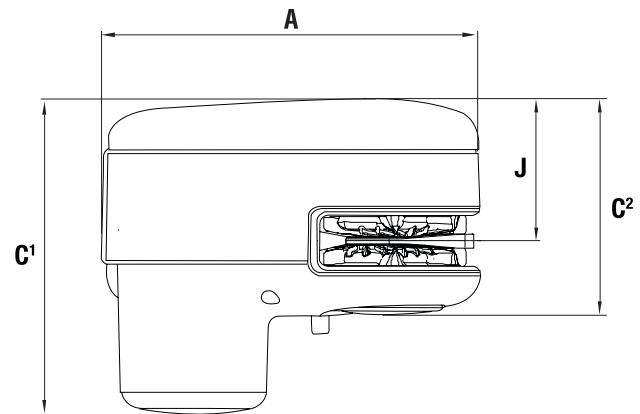

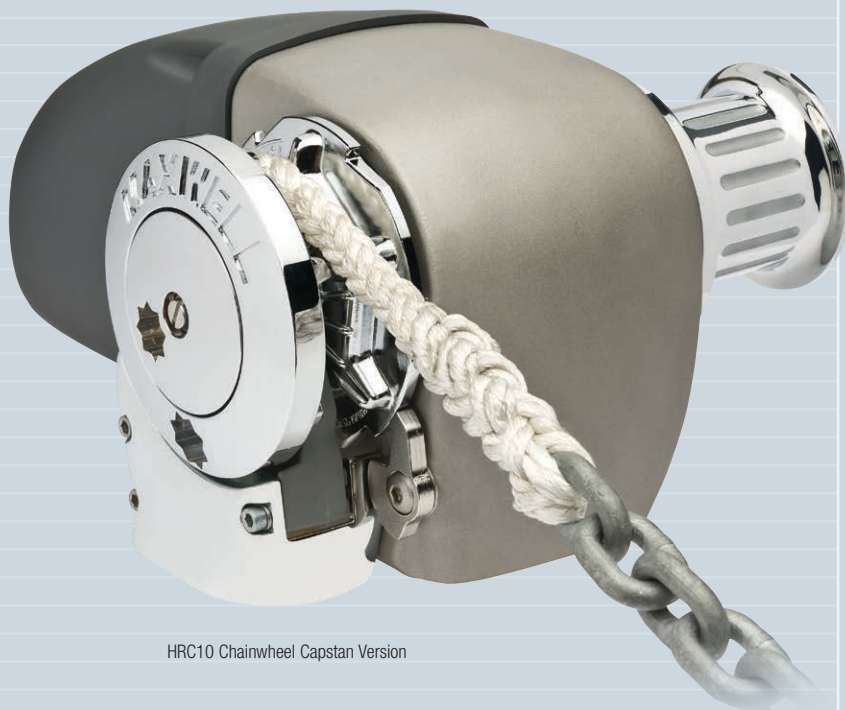

HRC10 Chainwheel Capstan Version



HRC10 Non Capstan Version

3 YEAR
Limited Warranty

STANDARD EQUIPMENT REQUIRED FOR DUAL DIRECTION CONTROL

- Dual Direction Solenoid (included)
- Emergency crank/clutch release handle (included)
- Up/Down remote control panel (not included)
- Circuit breaker/isolator panel (not included)

Refer chart on page 340.

OPTIONS

1. AutoAnchor™ Equipment
2. Compact Remote
3. Foot Switches
4. Chain Stopper
5. Chain Snubber

The HRC10 Horizontal Series windlasses proudly follow in the highly successful footsteps of Maxwell's previous, fully automatic rope/chain anchor winches.

Features and benefits

- The all new HRC10 fully automatic horizontal windlass series is designed to effortlessly retrieve and deploy 8 mm (5/16") and 10 mm (3/8") short link chain and 14 mm (9/16") and 16 mm (5/8") three strand or 8-braid (plait) rope
- The more powerful HRC10-10 can be use with 10 mm (3/8") chain spliced to 16 mm (5/8") three strand or 8-braid (plait) rope
- The aesthetically pleasing above deck design, evolved from the philosophy of form follows function, encapsulates the motor and drive in a two part watertight case, saving space below deck
- The two part case consists of a die cast, marine-grade hard anodised alloy front section and a rugged and easily removable composite motor cover aft section
- This two piece watertight case allows for quick and easy, on-deck, routine maintenance
- Simple 'bolt down' installation ensures effortless and rapid on-deck installation and set up
- The stainless steel (AISI 316) pressure arm always exerts maximum control pressure on the rode (rope, splice or chain)
- The revolutionary patented Wave Design™ chainwheel is able to accommodate a wide range of chain pitch differences, within the specified chain size diameters, suitable for use with the HRC10 Series. Refer page 323 for more information about this innovative feature
- The unique Maxwell 'wrap around' horizontal chainwheel ensures that more than 90° of the wheel is used, allowing greatly improved rope and chain handling compared with competitor designs
- The HRC10 works just as effectively with all-chain rodes for those who desire the added security and holding power of an all-chain anchor system
- The integral chain pipe and huge, through deck hawse pipe throat ensures easy entry of the rope/chain rode into and out of the anchor locker
- Cone type clutch/brake mechanism permits manual, 'free fall' anchoring and emergency crank recovery of the rode and anchor if required
- The sealed oil bath and marine-grade hard anodised, alloy gearbox provides high efficiency output drive via precision worm and wormwheel

3 YEAR
Limited Warranty

Eye-catching fully automatic horizontal windlass with great capacities

SPECIFICATIONS

Model	HRC10-8* 8 mm - 5/16"	HRC10-10* 10 mm - 3/8"
Maximum Pull/Lift	700 kg 1540 lbs	850 kg 1870 lbs
Static Hold	1500 kg 3300 lbs	1500 kg 3300 lbs
Chain Short Link	8 mm 5/16"	10 mm 3/8"
Rope Size	14 mm - 16 mm 9/16" - 5/8"	16 mm 5/8"
Chain Speed (Anchor Retrieval)	24 m/min 79 ft/min	24 m/min 79 ft/min
Rope Speed (Anchor Retrieval)	20 m/min 65 ft/min	20 m/min 65 ft/min
Power Supply (DC)	12 or 24 V	12 or 24 V
Motor (Watts)	1000 W	1200 W
Net Weight	19 kg 42 lbs	20 kg 44 lbs
Hydraulic Pressure	138 bar 2000 psi	138 bar 2000 psi
Hydraulic Flow	20 L/min 5.3 USgal/min	20 L/min 5.3 USgal/min
Net Weight - Hyd	13 kg 28 1/2 lbs	13 kg 28 1/2 lbs

Non Capstan Version. Weight is 1kg/2.2lbs less than above indicated.

*8 mm - 5/16" or 10 mm - 3/8" chainwheels can be used on either of the above models

DIMENSIONS

Model	HRC10-8* 8 mm - 5/16"	HRC10-10* 10 mm - 3/8"
A	369 mm 14 9/16"	369 mm 14 9/16"
B	199 mm 7 7/8"	199 mm 7 7/8"
C ¹	316 mm 12 1/2"	316 mm 12 1/2"
C ²	225 mm 8 7/8"	225 mm 8 7/8"
C ³	140 mm 5 1/2"	140 mm 5 1/2"
D	80 mm 3 3/16"	80 mm 3 3/16"
E (standard deck clearance)	90 mm 3 9/16"	90 mm 3 9/16"
F	92 mm 3 9/16"	92 mm 3 9/16"
G	110 mm 4 3/8"	110 mm 4 3/8"
H	80 mm 3 3/16"	80 mm 3 3/16"
J	99 mm 4"	99 mm 4"

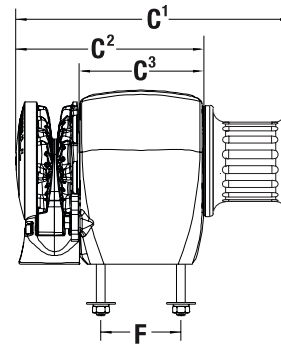
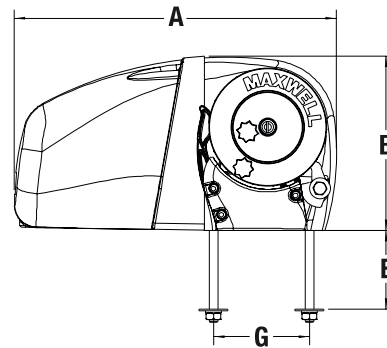
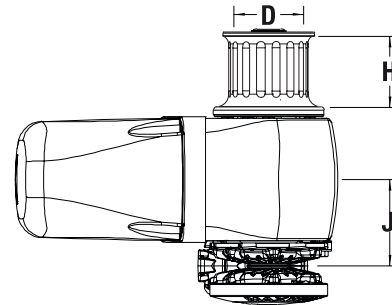

Important: Maxwell windlasses must be used in conjunction with a chain stopper or alternative snubbing device to take the load off the windlass while laying at anchor. The chain stopper and alternative snubbing system should also be used to secure the anchor in the fully raised position while under way.





The HWC Series is designed for automatic horizontal handling of chain-only anchor rodes while offering an independent capstan for the retrieval of a secondary rope and chain rode or to assist with docking procedures.



HWC3500 Chainwheel Capstan Version

Features and benefits

- Fully automatic single or dual direction chainwheel operation, for use with chain only rodes
- Functional rope hauling from fore and aft using independent fluted stainless steel snag-free warping drum with clutch disengagement of chainwheel for positive control of all ropes
- Optional dual anchor handling with smooth independent control of each chainwheel via cone clutches
- Chain pipe assembly supplied
- Cone-type clutch/brake mechanism permits manual 'free fall' anchoring. Cone clutches, unlike dog clutches, provide smooth progressive engagement ensuring safe and precise operator control
- Chainwheel locking pawl to assist when using warping drum independently
- Simple deck mounted installation with no under deck parts
- Simplified maintenance with ability to strip the running gear (chainwheel and drum) from the windlass without disturbing the windlass mounting
- Heavy duty, dual direction motor, designed for marine winches
- Chainwheel and warping drum of high-quality chrome finish over marine-grade bronze
- Marine-grade alloy casing pretreated, powder coated and finished with a two component white polyurethane paint

3 YEAR
Limited Warranty



HWC3500 Double Chainwheel Capstan Version

STANDARD EQUIPMENT REQUIRED FOR DUAL DIRECTION CONTROL

- Dual Direction Solenoid (included)
- Chain pipe and chainwheel to suit chain size specified (included)
- Emergency crank/clutch release handle (included)
- Up/Down remote control panel (not included)
- Circuit breaker/isolator panel (not included)

OPTIONS

- | | |
|---------------------------------|--------------------|
| 1. AutoAnchor™ Equipment | 5. Hydraulic motor |
| 2. Foot Switches | 6. Compact Remote |
| 3. Chain Stopper* | 7. Roving remote |
| 4. Up/Down remote control panel | |

3 YEAR
Limited Warranty

Horizontal handling for chain-only anchor rodes

SPECIFICATIONS

MODEL	2500	3500	HWVC3500
Maximum Pull/Lift	1135 kg 2500 lbs	1590 kg 3500 lbs	1590 kg 3500 lbs
Static Hold	2200 kg 4840 lbs	2200 kg 4840 lbs	2200 kg 4840 lbs
Chain Short Link	9-11mm 3/16"- 3/8"	8-13mm 3/8"- 1/2"	8-13mm 3/8"- 1/2"
Line Speed (Normal Working)	15 m/min 50 ft/min	15 m/min 50 ft/min	10 m/min 33 ft/min
Power Supply (DC)	12 or 24 V	12 or 24 V	12 or 24 V
Motor (Power)	1200 W	1200 W	1200 W
Net Weight - DC	55 kg 121 lbs	57 kg 125 lbs	94.5 kg 208 lbs
Hydraulic Pressure	135 bar 1950 psi	138 bar 2000 psi	138 bar 2000 psi
Hydraulic Flow	36 l/min 9.5 USgal/min	40 l/min 11 USgal/min	40 l/min 11 USgal/min
Net Weight - Hyd	48.5 kg 107 lbs	49 kg 107 lbs	80 kg 176 lbs

DIMENSIONS

MODEL	2500	3500	HWVC3500
A	495 mm 19 1/2"	515 mm 20 9/32"	515 mm 20 9/32"
B	289 mm 11 3/8"	316 mm 12 7/16"	446 mm 17 9/16"
C	516 mm 20 5/16"	549 mm 21 5/8"	710 mm 28"
D (Hole centres)	234 mm 9 1/4"	260 mm 10 1/4"	417 mm 18 7/16"
F (Hole centres)	278 mm 10 15/16"	308 mm 12 1/8"	464 mm 18 1/4"
G (Approximate hole centres)	300 mm 11 13/16"	348 mm 13 11/16"	348 mm 13 11/16"
H (Working height of drum for rope warping)	60 mm 2 3/8"	53 mm 2 3/32"	53 mm 2 3/32"
I	125 mm 4 15/16"	130 mm 5 1/8"	130 mm 5 1/8"
J	194 mm 7 5/8"	208 mm 8 3/16"	287 mm 11 19/64"

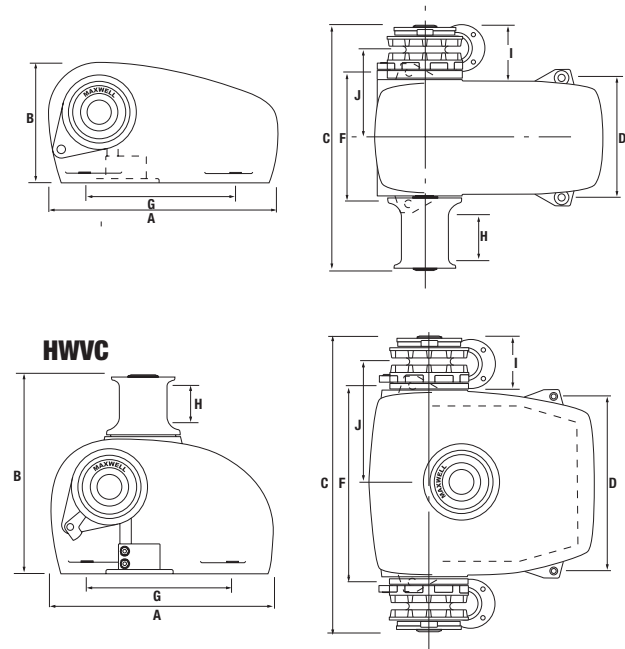

Important: Maxwell windlasses must be used in conjunction with a chain stopper or alternative snubbing device to take the load off the windlass while laying at anchor. The chain stopper and alternative snubbing system should also be used to secure the anchor in the fully raised position while under way.



KADEY KROGEN 58' FITTED WITH HWVC3500





A new heavy duty winch has arrived:
explore our TASMAN Series!

Features

- Robust, reliable, high performance Drum Winch
- Exceptional performance using Maxwell proven gearbox and motor
- Long life - Stainless Steel and Marine Anodised construction
- Easy install through separate legs and flexibility of motor positioning
- Simple emergency operation allows anchor deployment if power is lost
- Maxwell proprietary gearbox - custom ratio for optimised performance, direct fit to larger diameter shafts, large bearings and seals, robust design
- Proven Maxwell 1000W motor on the TASMAN 8 and 600W motor on TASMAN 6 series
- Large diameter high strength shaft - higher holding load and improved resistance to bending
- Large diameter plain bearings for a longer life, stronger and more robust in the harsh marine environment.
Non gearbox end is self lubricated composite bearing for minimal maintenance
- MAX Warp - high strength combined with stretch for absorbing shock loads - optimised rope construction for maximum hold with enough stretch to minimise impact loads when anchored
- Engineered mounting design, optimised for strength, compact dimensions through integration with gearbox
- High quality marine galvanised chain

STANDARD EQUIPMENT REQUIRED FOR DUAL DIRECTION CONTROL

Dual Direction Solenoid (included)

Up/Down remote control panel (included)

Circuit breaker/isolator panel (included)

OPTIONS

1. AutoAnchor™ Equipment
2. Foot Switches
3. Chain Stopper*
4. Compact Remote
5. Roving remote



Tasman 8



Tasman winch, reel in true adventure

SPECIFICATIONS

MODEL	6-6	6-4	8-8	8-6
Electric motor	DC	DC	DC	DC
Motor power	600 W	600 W	1000 W	1000 W
Voltage (V)	12 or 24	12 or 24	12 or 24	12 or 24
Max Pulling force				
- 1 layer on drum	700 kg 1540 lbs	700 kg 1540 lbs	1000 kg 2200 lbs	1000 kg 2200 lbs
- Full drum	100 kg 220 lbs	100 kg 220 lbs	350 kg 770 lbs	350 kg 770 lbs
Haulage Speed				
- 1 layer on drum	50 m/min	50 m/min	60 m/min	60 m/min
- Full drum	7.5 m/min	13 m/min	13 m/min	13 m/min
Rope size				
	6 mm MAX warp x 70 m	4 mm UHMWPE x 100 m + 6 mm MAX warp x 10 m	8 mm MAX warp x 100 m	6 mm MAX warp x 150 m
Chain size				
	6 mm Short Link DIN766 x 10 m	6 mm Short Link DIN766 x 10 m	8 mm Short Link DIN766 x 10 m	6 mm Short Link DIN766 x 10 m
Net weight (incl. rope/chain)				
	24 kg	24 kg	37 kg	31 kg

DIMENSIONS

MODEL	TASMAN 6		TASMAN 8	
	mm	inch	mm	inch
A	200	7 7/8	300	11 3/4
B	180	7 1/16	200	7 7/8
C	210	8 1/4	310	12 1/4
D	155	6 1/16	165	6 1/2
E	209	8 1/4	229	9
F	259	10 3/16	280	11

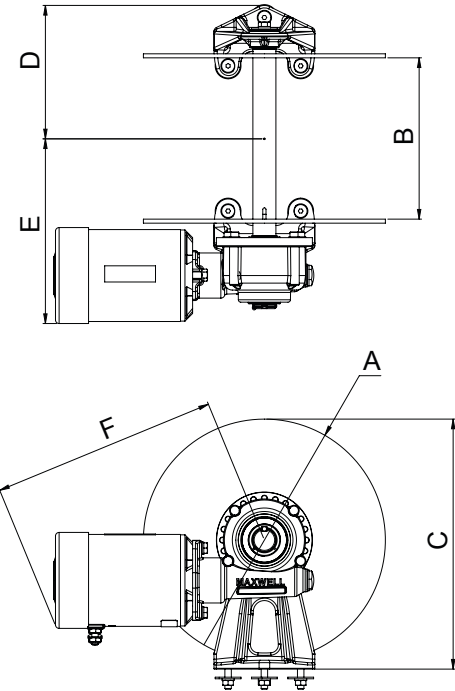

Tasman 6





When it comes to anchoring, Maxwell provides the ultimate anchoring solution backed by sound advice and after sales service. A full range of anchoring accessory items are available. Please contact your nearest Maxwell office or local distributor for helpful advice and assistance.

Maxwell will supply not only your anchor winch or capstan, but also a complete anchoring package consisting of control gear, circuit protection, anchors, rope, chain, chain stoppers, chain snubbers, swivels, shackles, bow rollers, etc.

UP/DOWN CONTROLS

Easy to use, panel-mounted Up/Down switches for remote windlass operation from the helm, fly bridge or cockpit. Suitable for use with dual-directional solenoids.

- Manufactured from marine-grade materials
- Splash proof
- Suitable for 12 and 24 Volt DC use
- Includes on/off switch and power indicator light (B only)



UP/DOWN REMOTE PANEL (TOGGLE TYPE) (P102938)

(A)



UP/DOWN REMOTE PANEL (PUSH BUTTON TYPE) (P102983)

(B)

Accessories Positioning Guide

The correct installation of your Maxwell windlass or capstan and all associated anchoring equipment will ensure that you get years of trouble free service. It is worth taking the time to install all accessories and electrical wiring or hydraulic connections carefully and professionally. Your Maxwell Owner's Manual will provide you with all the information you, or your service agent, needs to properly set up your specific installation. The indicative diagram gives you some idea of what is involved and is a guide only.

Note: All the accessories shown are not necessarily available from every Maxwell warehouse. Please contact your nearest Maxwell office for availability.

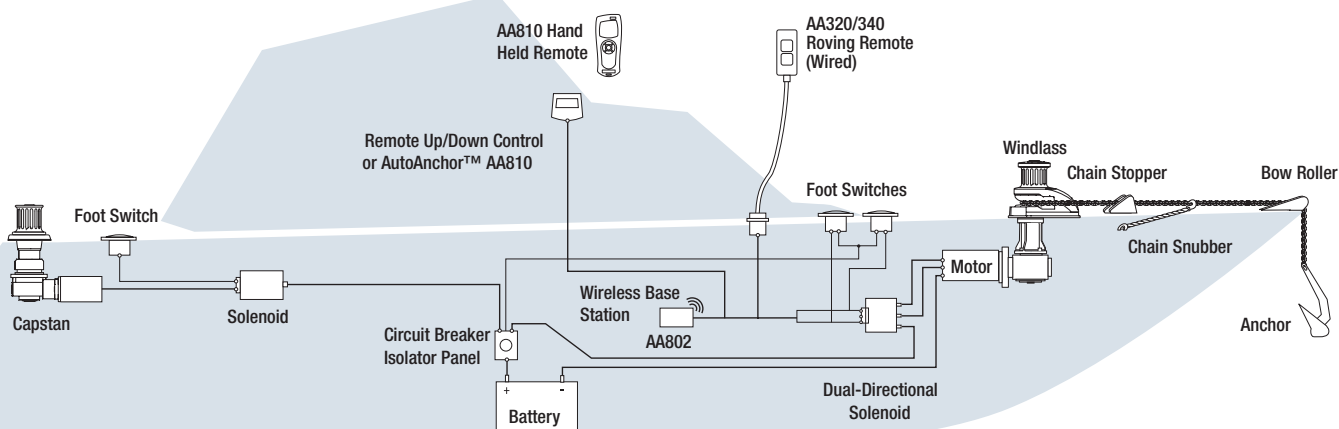

HEAVY DUTY FOOT SWITCH

Maxwell heavy-duty, weather resistant units have a UV stabilised water proof membrane and are supplied complete with mounting instructions and screws.

- Rated at 150 amps maximum current and suitable for 12 or 24 V applications
- Nickel-plated copper contacts ensure corrosion-free, reliable operation



BLACK COVERED
WHITE COVERED
STAINLESS STEEL COVERED

P19006
P19007
P100735

BLACK PLASTIC BEZEL
STAINLESS STEEL BEZEL

P19008
P19001

COMPACT FOOT SWITCH

Maxwell's, compact up and down foot switches now available in black and white cover versions. These 5 Amp rated switches are required to be operated via solenoids, which also allows for smaller diameter wiring.



WHITE COVERED **P104809**
BLACK COVERED **P104810**

CIRCUIT BREAKER/ISOLATOR PANELS

Maxwell circuit breaker/isolator panels are available to suit a wide range of windlasses and capstans.

- For protection of the main conductor circuit for DC winches
- Enables the battery, or electrical supply, to be isolated when winch is not in use
- Suitable for 12 or 24 V DC systems



P100789 40 AMP
P100790 80 AMP

P100791 135 AMP
P102903 70 AMP

DUAL AND SINGLE DIRECTION SOLENOIDS

Dual Direction Solenoids are used in conjunction with remote Up/ Down panel, AutoAnchor™ Rode Counters, roving hand held remote controls and/or foot switches to switch the motor in the required direction.

- Heavy-duty solenoids, suitably rated for our winch motors
- Available in 12 or 24 V DC for permanent magnet 2 terminal (PM), series wound 3 terminal (SW) and Field wound 4 terminal (FW) motors
- Ignition protected solenoids
- Installation in a dry area is always recommended



Single Direction Solenoids should be used where only single direction motor rotation is necessary. E.g. capstan winches.

SINGLE DIRECTION **SP1393 12V (PM/SW)**
SINGLE DIRECTION **SP1394 24V (PM/SW)**

DUAL DIRECTION **SP5102 12V (PM)**
DUAL DIRECTION **SP5103 24V (PM)**
DUAL DIRECTION **SP5104 12V (SW)**
DUAL DIRECTION **SP5105 24V (SW)**
DUAL DIRECTION **SP5106 24V SW (100% DUTY)**
DUAL DIRECTION **SP5107 24V (FW)**





MAXWELL AUTOANCHOR WIRELESS REMOTE CONTROLS

3 YEAR
Limited Warranty

AutoAnchor SmartBox - AA802

The World's most advanced chain counter has arrived. AutoAnchor presents the safest, easiest anchoring ever. The core of the New Generation range stands for less complications and more information at you finger tips when dropping anchor.

- Very accurate chain and rope count
- Simplified installation, set up and calibration.
- Daisy-chain wiring to read outs with a single cable or via Bluetooth
- NMEA2000 for 3rd party displays and for integrated information
- Bluetooth Wireless for excellent wireless coverage and links to smartphone apps or plotters

SmartBox technology opens up myriad of anchor monitoring possibilities when combined with 3rd party information such as GPS and depth. AutoAnchor can now transform other anchor watch software into a more comprehensive anchoring tool.



SmartConsole - AA870 / Smart Remote - AA810

- Fewer or no cables... rope counting simplified!
- Reliable wireless or NMEA2000 connectivity
- Effortless addition of multiple counters

(P105545)



(P105546)



SmartSensor - AA001

- 3-Axis Reading gives Auto Directional Detection; no need for Up / Down input signal
- Rope / Chain Auto Detection;
- No need for load wires.
- High Sensitivity for improved sensing distance



(SP5127)

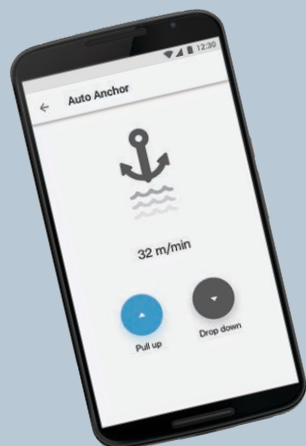

NEW!

With the AA8XX series of chaincounters you can now connect to the chain counter with your smart device or NMEA 2000 (May require software update) chart plotter and control the windlass negating the need for a helm mounted counter display. Note it is always recommended to have a direct wired control for the windlass.



PRODUCT FEATURES

- Windlass monitoring from the helm
- Simple Plug & Play sensor installation
- Accurate information for all-chain or combination rope/chain rodes
- Flexibility of magnet and sensor gap from 3 mm to 50 mm
- Easy set up
- Multiple unit installation options - combine with other Maxwell AA products for total windlass control
- Fits all DC, AC and hydraulic windlasses
- Inbuilt diagnostics for troubleshooting installation issues
- EMC protection to CE EN60945

MAXWELL AA710 WIRELESS, HAND HELD REMOTE WINDLASS CONTROLLER AND RODE COUNTER

All the features of the AA570 plus options to control a bow thruster or deck lights and anchor wash.

- High level wireless transmission security - 2.4GHz ISM band
- Hand held controller displays rode count plus signal strength and battery level
- Water resistant to IP67
- Console requires two AA batteries
- Rubber molding for grip and non-slip protection
- Ergonomic shape with wrist strap connector
- Console holder and protective cover
- Shockproof
- EEE 802.15.4 compliant

Kit includes: 1 hand held remote control and 1 base station, 1 sensor and 1 magnet.

Note: Two base stations can be operated by one remote to allow control of two windlasses. Plug and Play connectors, T-Connectors and Gender Adaptors are also available. Contact your Maxwell Dealer.



(P102981)

MAXWELL AA560 WIRED PANEL MOUNT WINDLASS CONTROLLER AND RODE COUNTER

(P102944)

SPECIAL FEATURES

- Preset stopping point and docking alarm on retrieval
- One-touch function to deploy and retrieve a preset length of rode
- Adjustable back lit display in feet, metres or fathoms
- Graphic LCD screen featuring intuitive user interface for simple operation
- Displays windlass speed and direction
- Safety lock to help protect against accidental windlass deployment
- Logs windlass operation hours to help ensure regular windlass maintenance
- Weather cover and choice of black or gray console

Kit includes 1 console, 1 sensor and 1 magnet



MAXWELL AA150 WIRED PANEL MOUNT RODE COUNTER

- Docking alarm
- Standard 60mm (2.36") marine instrument console
- Choice of feet or metre count readout
- Large, adjustable, backlit LCD display

Kit includes 1 console, 1 sensor and 1 magnet

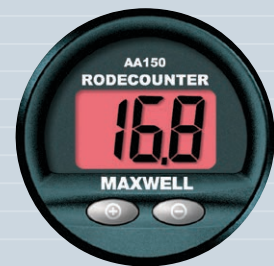

(P102939)

AUTOANCHOR WIRED ROVING REMOTE CONTROL UNITS

ANCHOR LAUNCHING OR RETRIEVAL FROM THE BOW WHEN VISION FROM THE HELM STATION IS OBSTRUCTED

- Use for Windlasses, Davits, Thrusters and other Marine Equipment
- Electrical protection against back-emf
- Rubber over-molding for shock protection and grip
- Stowage cradle
- Operate in parallel with all AutoAnchor™ products, toggle switches, foot switches or other control equipment
- Connect to DC, AC and Hydraulic systems
- Rugged 4.5 m coiled cable and connectors
- All products are rated to IP67 including cables, plugs and sockets
- Deck socket with 2 m flying lead reduces potential for corrosion (excluding AA320 series)
- Other Maxwell AutoAnchor controllers are available, check with your local Maxwell distributor

AA730 With Rode Counter (P102994)



AA320 Windlass Control (P102992)

AA342* Dual Windlass Controller (P102996)



4 metres cable

* AA341 Model (P102995) is similar to AA342 but can be used as a general dual equipment controller (contact Maxwell for details).



Gender Adaptor
Cable Connector
(SP4192)



Dual Installation
T Connector
(SP4155)





The MAXSET Bow Roller design guarantees that MAXSET stainless steel and galvanised anchors, along with similar competitor versions, are efficiently self-launched during anchor deployment. When the anchor is fully retrieved, the MAXSET bow roller ensures that the anchor fits securely into the roller and will not rattle around when the boat is under way.

MAXSET BOW ROLLERS

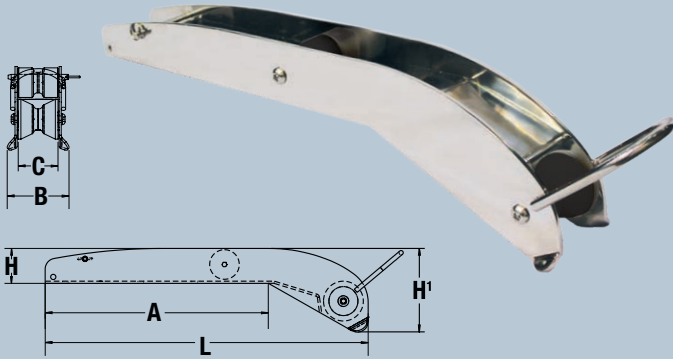

MAXSET ANCHORS AND MAXSET BOW ROLLERS

		Polished Finish				
MAXSET (Delta Style Anchors)	MAXSET Bow Roller Codes	P105075	P105077	P105079	P105081	P105083
	4kg/9lbs		•			
6kg/13lbs		•				
10kg/22lbs			•			
16kg/35lbs				•		
20kg/44lbs					•	
25kg/55lbs						•
30kg/66lbs						•
40kg/88lbs						•

EXTENDABLE HINGED BOW ROLLER



FIXED BOW ROLLER WITH ANCHOR LOOP

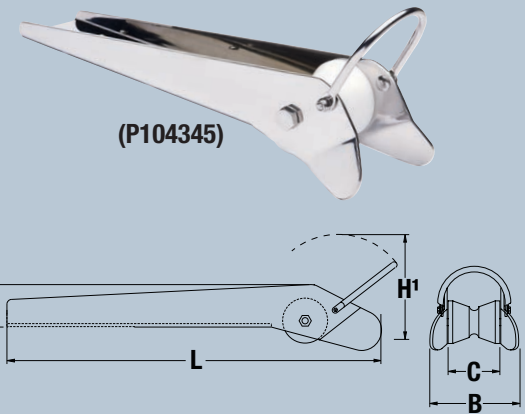

SHORT EXTENSION POSITION

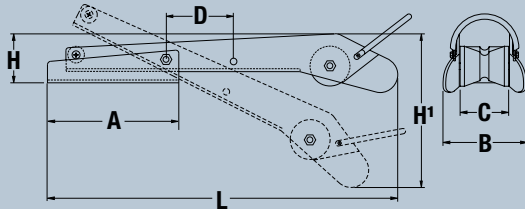

MAXSET ANCHORS AND BOW ROLLERS

Standard Bow Roller Codes	P104331	P104332	P104333	P104334	P104340	P104345
MAXSET (Delta Style Anchors)						
4 kg/9 lbs		•	•		•	•
6 kg/13 lbs		•	•		•	•
10 kg/22 lbs	•	•	•		•	•
16 kg/35 lbs		•	•	•	•	•
20 kg/44 lbs				•		
25 kg/55 lbs				•		
Standard Bow Roller Codes	P104331	P104332	P104333	P104334	P104340	P104345
MAXCLAW (Claw Style Anchors)						
5 kg/11 lbs		•	•		•	
8 kg/18 lbs		•	•		•	•
10 kg/22 lbs	•	•	•	•	•	•
15 kg/33 lbs				•	•	•
20 kg/44 lbs				•		

MAXSET AND STANDARD BOW ROLLER DIMENSIONS

	Extendable P104340	Fixed with Hoop P104345	P105074 P105075	P105076 P105077	P105078 P105079	P105080 P105081	P105082 P105083
A	198 mm (7 13/16")	N/A	315 mm (12 3/8")	414 mm (16 5/16")	480 mm (18 7/8")	510 mm (20")	560 mm (22")
B	125 mm (4 15/16")	134 mm (5 1/4")	84 mm (3 5/16")	112 mm (4 3/8")	112 mm (4 3/8")	114 mm (4 1/2")	153 mm (6")
C	73 mm (2 7/8")	75 mm (3")	62 mm (2 1/2")	78 mm (3")	78 mm (3")	78 mm (3")	105 mm (4 1/8")
D	101 mm (4")	N/A	N/A	N/A	N/A	N/A	N/A
H	75 mm (2 15/16")	65 mm (2 9/16")	55 mm (2 1/8")	65 mm (2 1/2")	72 mm (2 13/16")	78 mm (3")	95 mm (3 3/4")
H'	239 mm (9 3/8")	155 mm (6 1/8")	122 mm (4 13/16")	152 mm (6")	165 mm (6 1/2")	175 mm (6 7/8")	215 mm (8 1/2")
L	527 mm (20 1/4")	460 mm (18 1/8")	465 mm (18 5/16")	600 mm (23 5/8")	715 mm (28 1/8")	762 mm (30")	850 mm (33 1/2")

BOW ROLLERS

HINGED BOW ROLLER

Suitable for rope and chain anchor rodes utilising up to 13 mm (1/2") chain.



HINGED BOW ROLLER DIMENSIONS

Code	Type	L	B	H	h	C
P104330	Size 1	320 mm (12 5/8")	92 mm (3 5/8")	72 mm (2 7/8")	133 mm (5 1/4")	44 mm (1 3/4")
P104331	Size 2	430 mm (16 15/16")	160 mm (5 5/16")	100 mm (4")	190 mm (7 1/2")	66 mm (2 11/16")

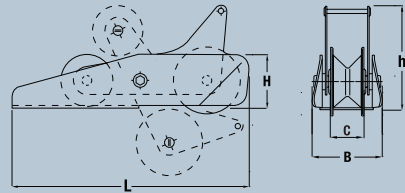

FIXED BOW ROLLER

Suitable for rope and chain anchor rodes utilising up to 13 mm (1/2") chain.



FIXED BOW ROLLER DIMENSIONS

Code	Type	L	B	H	C
P104332	Size 1	205 mm (8 1/8")	72 mm (2 7/8")	74 mm (3")	44 mm (1 3/4")
P104333	Size 2	320 mm (12 5/8")	86 mm (3 7/16")	74 mm (3")	44 mm (1 3/4")
P104334	Size 3	444 mm (17 1/2")	110 mm (4 3/8")	110 mm (4 3/8")	68 mm (2 11/16")

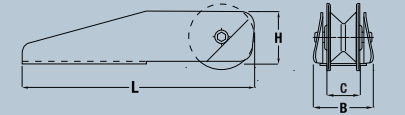

CHAIN STOPPERS

Taking the load off the windlass

Chain stoppers hold the chain and take the load off the windlass. Always use a chain stopper to set and ride on the anchor, break free the anchor or to prevent accidental free fall of the anchor while under way.

To suit any installation figuration of chain stoppers and windlass combinations, Maxwell offers 3 types of chain stoppers: Height Matched, Levered and Economy.



Height Matched



Economy



Levered

CHAIN STOPPER DIMENSIONS

	Height Matched		Levered			Economy
	RC8 (P104358)	RC10/12 (P104359)	8 mm (P104372)	10 mm (P104373)	13 mm (P104374)	8/10 mm (P104335)
B	105 mm (4 1/8")	127 mm (5")	72 mm (2 7/8")	86 mm (3 7/16")	105 mm (4 3/16")	62 mm (2 3/8")
C	40 mm (1 9/16")	48 mm (1 7/8")	20 mm (7/8")	20 mm (7/8")	26 mm (1 1/8")	6 mm (1/4")
F	150 mm (5 15/16")	182 mm (7 3/16")	152 mm (6")	190 mm (7 1/2")	219 mm (8 5/8")	80 mm (3 1/8")
G	130 mm (5 1/8")	159 mm (6 1/4")	92 mm (3 5/8")	130 mm (5 1/8")	159 mm (6 5/16")	46 mm (1 3/4")
G ⁱ	10 mm (7/16")	11.5 mm (1/2")	30 mm (1 3/16")	30 mm (1 3/16")	30 mm (1 3/16")	17 mm (5/8")
I	77 mm (3")	97 mm (3 13/16")	70 mm (2 7/8")	86 mm (3 1/2")	100 mm (4")	92 mm (3 5/8")
J	44 mm (1 3/4")	53 mm (2")	31.5 mm (1 1/4")	44 mm (1 3/4")	53 mm (2 1/8")	N/A
J ⁱ	8.8 mm (11/32")	12.5 mm (1/2")	10 mm (7/16")	10 mm (7/16")	12.5 mm (1/2")	37 mm (1 1/2")
K	61.5 mm (2 7/16")	78 mm (3")	51.5 mm (2 1/8")	64 mm (2 5/8")	78 mm (3 1/8")	74 mm (2 7/8")
L	90 mm (3 1/2")	125 mm (4 15/16")	95 mm (3 3/4")	95 mm (3 3/4")	130 mm (5 1/8")	N/A
M	M8	M10	M10	M10	M12	M10

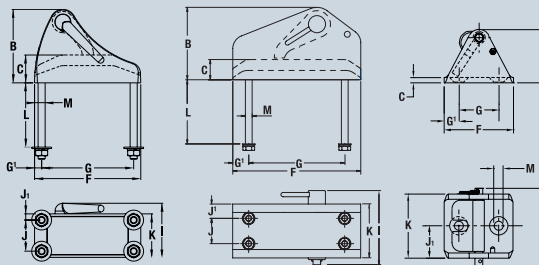

STOPPER TENSIONER

The 10-13 mm chain stopper is now available with integral anchor tensioner which is used to pull the stowed anchor tightly into the bow roller or anchor pocket preventing unwanted noise from the anchor pocket and unwanted noise from the anchor moving.

A retro-fit kit is available to fit the tensioner assembly onto existing Maxwell 10-13 mm chainstopper bodies.

P105257 - Stopper Tensioner 10-13 mm Removable Lever

P104740 - Stopper Tensioner Retrofit Kit for 13 mm Chainstoppers



WEBBING TENSIONER

Also available is a webbing strap tensioner for use on 7-12 mm chains.

The webbing tensioner simply fits to a deck cleat/bollard and uses a stainless steel claw to grip the chain and an over center cam lock to tensioner and secure the anchor.

P105072 - Webbing Tensioner 7-12 mm





When it comes to anchoring, Maxwell provides the ultimate anchoring solution backed by sound advice and after sales service. A full range of anchoring accessory items are available. Please contact your nearest Maxwell office or local distributor for helpful advice and assistance.

MAXSET ANCHORS

The "MAXSET" galvanised and stainless steel (AISI 316) anchor range, based on the proven 'Plough' design is available in eight different sizes to suit boats from approximately 4 metres (15') to 18 metres (58').

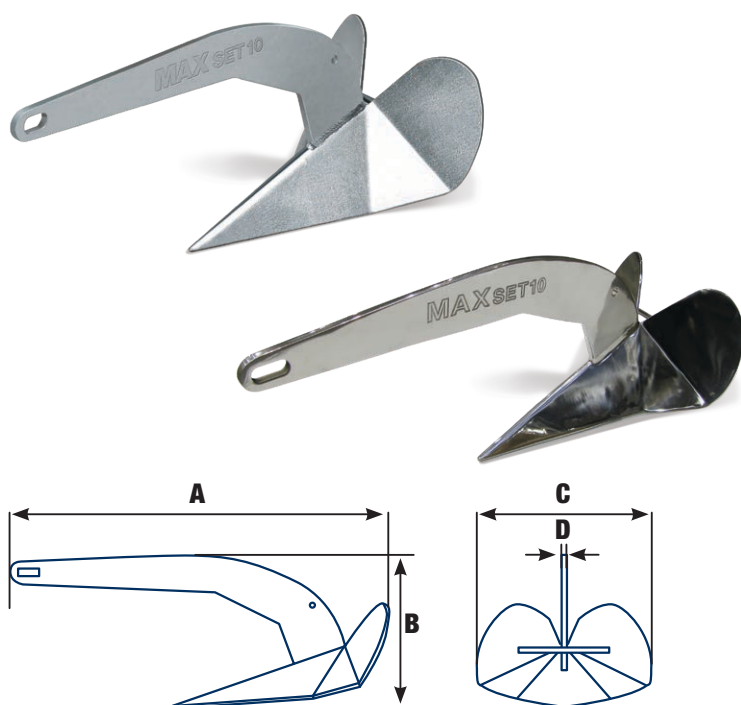

MAXCLAW ANCHORS

The "MAXCLAW" 316 Stainless Steel anchor range, based on the proven 'North Sea' claw design is available in seven different sizes to suit boats from approximately 4 metres (12') to 17 metres (55').

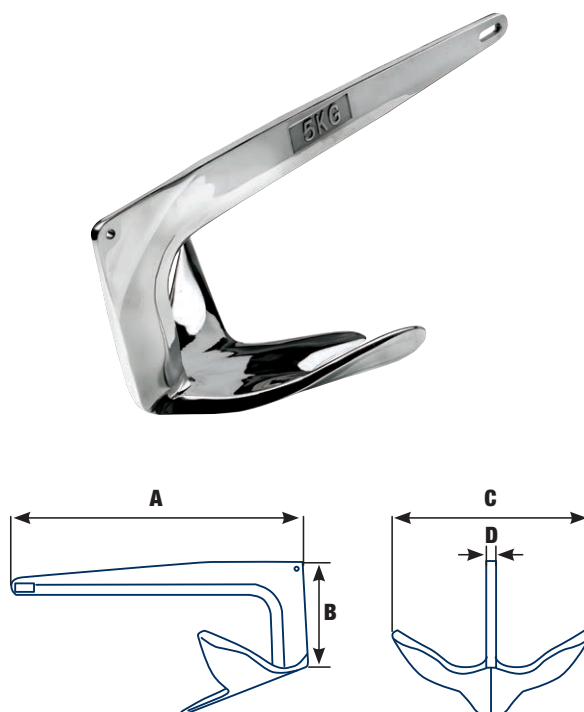

MAXSET ANCHORS STAINLESS STEEL	MAXSET ANCHORS GALVANISED	ANCHOR WEIGHTS	A	B	C	D
P105070	P105069	4 kg/9 lbs	530 mm (20 7/8")	222 mm (8 3/4")	245 mm (9 5/8")	8 mm (5/16")
P105055	P105000	6 kg/13 lbs	620 mm (24 1/2")	230 mm (9 1/8")	262 mm (10 3/8")	10 mm (3/8")
P105056	P105001	10 kg/22 lbs	730 mm (28 3/4")	275 mm (10 7/8")	315 mm (12 1/2")	12 mm (1/2")
P105057	P105002	16 kg/35 lbs	820 mm (32 3/8")	315 mm (12 1/2")	340 mm (13 1/2")	14 mm (9/16")
P105058	P105003	20 kg/44 lbs	890 mm (35")	345 mm (13 5/8")	400 mm (15 3/4")	16 mm (5/8")
P105059	P105004	25 kg/55 lbs	986 mm (38 7/8")	410 mm (16 1/8")	445 mm (17 1/2")	16 mm (5/8")
P105067	P105005	30 kg/66 lbs	1050 mm (38 7/8")	445 mm (16 1/8")	465 mm (17 1/2")	20 mm (5/8")
P105068	P105006	40 kg/88 lbs	1130 mm (44 1/2")	470 mm (18 1/2")	510 mm (20")	20 mm (3/4")

MAXCLAW STAINLESS STEEL	ANCHOR WEIGHTS	A	B	C	D
P105060	5 kg/11 lbs	470 mm (18 5/8")	190 mm (7 1/2")	310 mm (12 1/4")	15 - 18 mm (5/8"-3/4")
P105061	8 kg/18 lbs	530 mm (20 7/8")	210 mm (8 3/8")	360 mm (14 1/4")	15 - 18 mm (5/8"-3/4")
P105062	10 kg/22 lbs	600 mm (23 5/8")	228 mm (9")	380 mm (15")	15 - 18 mm (5/8"-3/4")
P105063	15 kg/33 lbs	670 mm (26 1/2")	265 mm (10 1/2")	450 mm (17 3/4")	15 - 18 mm (5/8"-3/4")
P105064	20 kg/44 lbs	715 mm (28 1/4")	360 mm (14 1/4")	470 mm (18 5/8")	15 - 20 mm (5/8"-7/8")
P105065	30 kg/66 lbs	815 mm (32 1/8")	425 mm (16 3/4")	550 mm (21 3/4")	18 - 25 mm (3/4"-1")
P105066	40 kg/88 lbs	1000 mm (39 3/8")	440 mm (17 3/8")	675 mm (26 5/8")	18 - 30 mm (3/4"-1 1/4")



MAXSET ANCHORS AND MAXSET BOW ROLLERS

See chart below to select the most suitable bow roller for use with your MAXSET or MAXCLAW anchor.

MAXSET ANCHORS			TO SUIT APPROXIMATE BOAT LENGTH												MAXSET BOW ROLLERS			
Stainless Steel	Galvanised	Weight	4M (13')	6M (20')	8M (26')	10M (33')	12M (39')	14M (46')	16M (52')	18M (59')							Satin Finish	Polished Finish
P105070	P105069	4 kg/9 lbs	■														P105074	P105075
P105055	P105000	6 kg/13 lbs		■													P105074	P105075
P105056	P105001	10 kg/22 lbs			■												P105076	P105077
P105057	P105002	16 kg/35 lbs				■											P105078	P105079
P105058	P105003	20 kg/44 lbs					■										P105080	P105081
P105059	P105004	25 kg/55 lbs						■									P105082	P105083
P105067	P105005	30 kg/66 lbs							■								P105082	P105083
P105068	P105006	40 kg/88 lbs								■							P105082	P105083

MAXCLAW ANCHORS			TO SUIT APPROXIMATE BOAT LENGTH															
P105060		5 kg/11 lbs	■															
P105061		7.5 kg/17 lbs		■														
P105062		10 kg/22 lbs			■													
P105063		15 kg/33 lbs				■												
P105064		20 kg/44 lbs					■											
P105065		30 kg/66 lbs						■										
P105066		40 kg/88 lbs							■									



ANCHOR SWIVEL SHACKLES



6-8 MM (P104370)



10-13 MM (P104371)

ANCHOR SWIVEL SHACKLES

Improve your anchor retrieval

The use of a swivel and joining shackle for your anchor and rode will greatly improve anchor retrieval and help ensure that the rode lays neatly into your anchor locker.

Maxwell has 2 available sizes for use with its automatic rope/chain series windlasses to suit vessels up to 20 metres (65 feet):

- 6-8 mm (1/4" - 5/16")
- 10-13 mm (3/8" - 1/2")

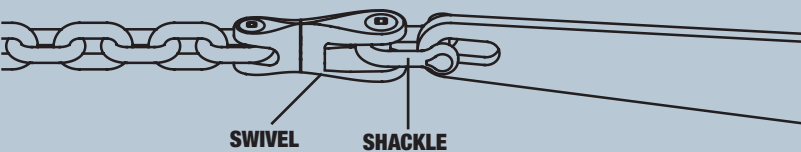

EMERGENCY CRANK/CLUTCH RELEASE HANDLES AND BI-SQUARE EXTENSION DRIVES

Especially for RC and HRC Series

These crank handles are available in 2 different sizes to suit the constraints of most foredeck configurations. They are constructed of light weight, durable injection-molded plastic and will float if accidentally dropped overboard.

Bi-square drives are also available in a 150 mm inline extension for use on windlasses mounted in recessed lockers.

A Bi-square to 1/2" square drive adaptor which can be used in conjunction with standard 1/2" ratchets and tools.

BI-SQUARE EXTENSION AND 1/2" DRIVE

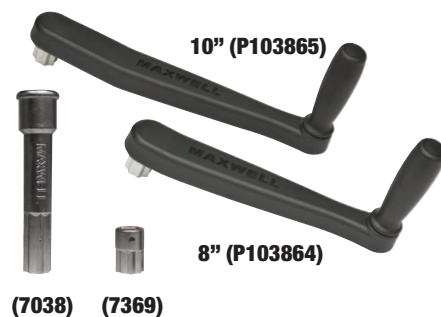

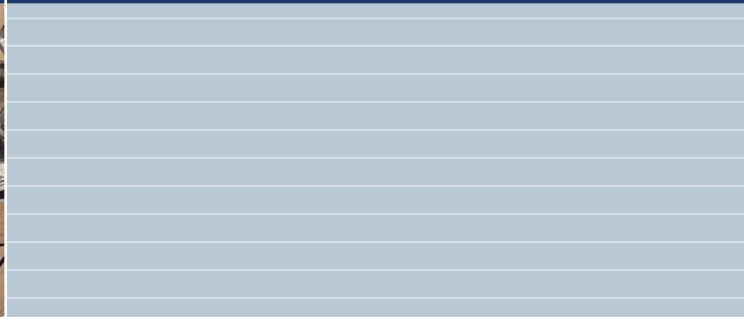

CHAINWHEEL SELECTION GUIDE

There are various grades of short link chain, relating to the raw metal quality, strength and finishing process. Both galvanised and stainless steel chains are available. In order for your windlass to retrieve and deploy the anchor and chain smoothly, without jamming, it is of great importance that the chain and chainwheeler (gypsy) match. Therefore Maxwell has devised a global chain and chainwheeler spreadsheet which will help you to figure out what kind of chainwheeler you need to order.

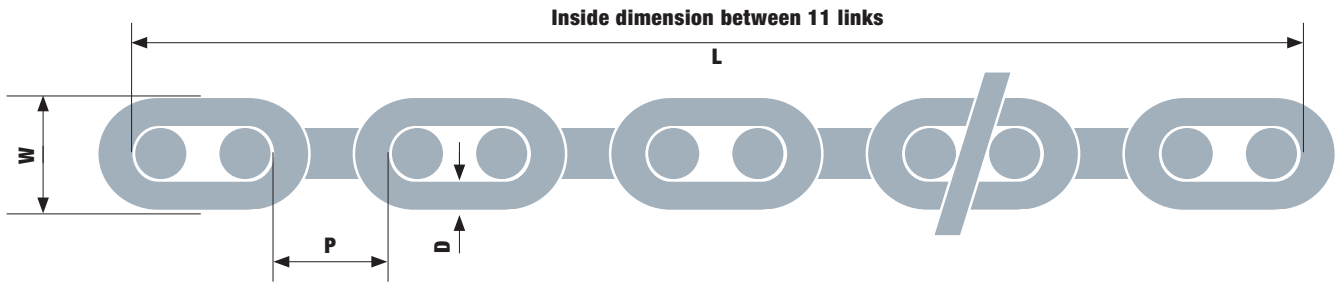

P = Pitch length inside link D = Chain wire diameter W = width outside the link L = inside dimension between 11 links.

Please take an 11 link section of your chain, lay it out in a stretched out straight line and measure the dimensions as indicated

DOWNLOAD THE MAXWELL CHAINWHEEL SELECTION GUIDE SPREADSHEET www.maxwellmarine.com/support_chainwheel.php

CHAINWHEEL SELECTION GUIDE																	
CHAIN	DIN766		EN818	TO SUIT APPROXIMATE BOAT SIZE													
	HOT DIP GALVANISED	STAINLESS STEEL	HOT DIP GALVANISED	4M (15FT)	5M (16FT)	6M (19FT)	7M (22F)	8M (26FT)	9M (30FT)	10M (32FT)	12M (38FT)	14M (45FT)	16M (52FT)	18M (58FT)	20M (65FT)	22M (72FT)	24M (78FT)
6 mm	SP3105	SP4471	N/A														
7 mm	SP4049	N/A	N/A														
8 mm	SP4050	SP4207	N/A														
10 mm	SP4051	SP2514	SP4012														
12 mm	N/A	N/A	SP3666														
13 mm	SP4052	SP4474	N/A														

CHAIN INFORMATION

There are various Grades of short link chain. The Grade relates to the raw metal quality, strength and finishing process. Both galvanised and stainless steel chains are available. Chain Specification is the Standard a chain must be manufactured to in order to comply with a given International Standard. Outside of North America the most common types of metric short link chain are DIN766 and EN-818. Within North America the most common imperial chains are BBB and G40. The important thing to keep in mind is to select a chain grade and specification that complies with recognised standards. In addition to the chains listed above, Maxwell can supply a variety of alternatives to meet any market demand. Please feel free to contact your nearest Maxwell dealer for assistance.

ROPE AND CHAIN

Maxwell can supply a full range of anchor rodes including chain-only, rope only or a pre-spliced combination of rope and chain rodes. Chains for vessels up to 100 metres (300 feet) and 8-plait (brait) nylon rope for vessels up to 20 metres (65 feet) in length as well as ropes and hawsers commonly used on superyachts.

Please see the pictures shown on this page for sizes and characteristics.

STANDARD COMBINATION ROPE CHAIN KITS						
CHAIN Ø	CHAIN LENGTH	ROPE Ø	ROPE LENGTH			
			50 m	100 m	150 m	200 m
6 mm	10 mtrs	12 mm	SP2627	SP2628	SP2629	SP2630
6 mm	20 mtrs	12 mm	N/A	SP2643	N/A	N/A
8 mm	10 mtrs	14 mm	SP2631	SP2632	SP2633	SP2634
8 mm	20 mtrs	14 mm	SP2644	SP2642	N/A	N/A
10 mm	10 mtrs	16 mm	SP2648	SP2649	N/A	N/A
10 mm	20 mtrs	16 mm	SP2645	SP2646	N/A	N/A

Custom lengths available. Contact your Maxwell Dealer.



NYLON 8 PLAIT ROPE

12MM (SP3167) 14MM (SP3168)
16MM (SP3169) 20MM (SP3170)

CHAIN SNUBBERS

Alternative method of taking the load of your windlass

These snubbers are recommended to secure the anchor while under way. Available in rope version with chain clevis hook. See picture below for the various sizes.



6 MM (SP3174)
8 MM (SP3175)
10 MM (SP3176)

ANCHOR TENSIONER

Simple, easy to use and adjustable tensioner

This innovative anchor tensioner secures the anchor firmly into the bow roller, taking the weight off the windlass and preventing accidental deployment of the anchor. The tensioner is suitable for use with 7 mm (¼") to 12 mm (½") short link chain and can be secured to an existing cleat or bollard so no installation is required.

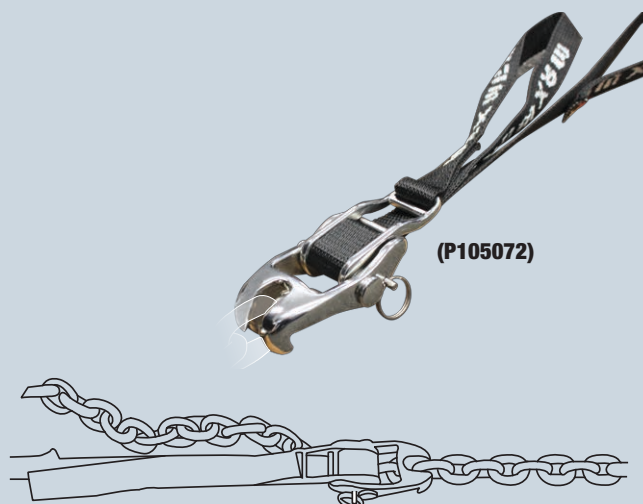

(P105072)



Electrical Accessories Selection Guide

Use this guide to select the electrical accessories you require and to confirm that they are suitable for use with your chosen windlass or capstan unit. After identifying your winch, follow steps 1 through 5 below. See also additional information on page 304.

1. Select Solenoid (when required)

	Windlass Model	Anchor Max	500VC	HRCFF 6/7/8	RC6	RC8-6	RC 8-8	RC 10-8	RC 10-10	HRC 10-8	HRC 10-10	RC 12-10	RC 12-12	RC 12HD	VW 10-8	VW 10-10	1000	1500	2500	3500	TASMAN
Part Number		500W	600W	600W	500W	600W	1000W	1000W	1200W	1000W	1200W	1200W	1200W	2000W	1000W	1200W	1000W	1200W	1200W	1200W	1000W
Reversing Solenoids																					
SP5102	Reversing Solenoid 12V			(*)	(*)	(*)															
SP5103	Reversing Solenoid 24V			(*)	(*)	(*)															
SP5104							(*)	(*)	(*)	(*)	(*)	(*)	(*)		(*)	(*)	(*)	(*)	(*)	(*)	(*)
SP5105	Reversing Solenoid 12V						(*)	(*)	(*)	(*)	(*)	(*)	(*)		(*)	(*)	(*)	(*)	(*)	(*)	(*)
SP5107	Reversing Solenoid 24V													(*)							
Single Direction Solenoids																					
SP1393	Single Direction 12V	•	•	Single Direction Solenoid may be used with windlass if dual direction operation is not required.																	
SP1394	Single Direction 24V	•	•																		
(•) = part of the standard 12V or 24V windlass package • = optional extra																					

2. Select Circuit Breaker/Isolator (recommended)

	Circuit Breaker	Anchor Max	500VC	HRCFF 6/7/8	RC6	RC8-6	RC 8-8	RC 10-8	RC 10-10	HRC 10-8	HRC 10-10	RC 12-10	RC 12-12	RC 12HD	VW 10-8	VW 10-10	1000	1500	2500	3500	TASMAN
P100789	40 Amp circuit breaker	24V	24V	24V	24V	24V															
P102903	70 Amp circuit breaker			12V	12V																
P100790	80 Amp circuit breaker	12V	12V			12V	24V	24V	24V	24V	24V	24V	24V		24V	24V	24V	24V	24V	24V	24V
P100791	135 Amp circuit breaker						12V	12V	12V	12V	12V	12V	12V	24V	12V	12V	12V	12V	12V	12V	12V

3. Select Switch or Combination of Switches (as required)

	Foot Switches	Anchor Max	500VC	HRCFF 6/7/8	RC6	RC8-6	RC 8-8	RC 10-8	RC 10-10	HRC 10-8	HRC 10-10	RC 12-10	RC 12-12	RC 12HD	VW 010-8	VW 10-10	1000	1500	2500	3500	TASMAN
P19001	Foot Switch With Chrome Bezel	•	•	•	•	•	•	•	•	•	•	•	•	•	•	•	•	•	•	•	•
P19006	Foot Switch Covered (Black)	•	•	•	•	•	•	•	•	•	•	•	•	•	•	•	•	•	•	•	•
P19007	Foot Switch Covered (White)	•	•	•	•	•	•	•	•	•	•	•	•	•	•	•	•	•	•	•	•
P19008	Foot Switch Plastic Bezel	(*)	•	•	•	•	•	•	•	•	•	•	•	•	•	•	•	•	•	•	•
P100735	Foot Switch Covered (Stainless Steel)	•	•	•	•	•	•	•	•	•	•	•	•	•	•	•	•	•	•	•	•
Compact Foot Switches																					
P104809	Foot Switch Covered (White)			•	•	•	•	•	•	•	•	•	•	•	•	•	•	•	•	•	•
P104810	Foot Switch Covered (Black)			•	•	•	•	•	•	•	•	•	•	•	•	•	•	•	•	•	•
Remote Panel (Up/Down)																					
P102938	Toggle Switch			•	•	•	•	•	•	•	•	•	•	•	•	•	•	•	•	•	•
P102983	Push Button			•	•	•	•	•	•	•	•	•	•	•	•	•	•	•	•	•	•
Hand Held Wired Roving Control																					
P102933	Roving Control Two Button			•	•	•	•	•	•	•	•	•	•	•	•	•	•	•	•	•	•
P102992	AA320 Roving Control Two Button			•	•	•	•	•	•	•	•	•	•	•	•	•	•	•	•	•	•
P102995	AA342 Roving Control Two Button			•	•	•	•	•	•	•	•	•	•	•	•	•	•	•	•	•	•

4. Select Rode Counters (when desired)

P102939	AA150 Panel Mount Rode Counter Without Control Switch			•*	•	•	•	•	•	•	•	•	•	•	•	•	•	•	•	•	•
P105545	AA870 Panel Mount Rode Counter and Windlass Control			•*	•	•	•	•	•	•	•	•	•	•	•	•	•	•	•	•	•
P102994	AA730 Wired Roving Control with Rode Counter			•	•	•	•	•	•	•	•	•	•	•	•	•	•	•	•	•	•
P105546	AA810 Wireless Remote Control with Rode Counter			•*	•	•	•	•	•	•	•	•	•	•	•	•	•	•	•	•	•

* HRC sensor P102909 is required to fit a chain counter to the HRCFF6 and HRCFF8 windlasses

5. Select Sensor Cable Extension Packs for Rode Counters or Switches with Rode Counters (as required)

SP4154	2m (6.5 ft) Dual Installation Connection cable			•	•	•	•	•	•	•	•	•	•	•	•	•	•	•	•	•	•
SP4156	6.5 m (21 ft)			•	•	•	•	•	•	•	•	•	•	•	•	•	•	•	•	•	•
SP4157	15 m (49 ft)			•	•	•	•	•	•	•	•	•	•	•	•	•	•	•	•	•	•
SP4153	20 m (65 ft)			•	•	•	•	•	•	•	•	•	•	•	•	•	•	•	•	•	•
SP4155	Dual Installation "T" Connector			•	•	•	•	•	•	•	•	•	•	•	•	•	•	•	•	•	•
SP4192	Gender Adaptor (to join 2 sensor cables)			•	•	•	•	•	•	•	•	•	•	•	•	•	•	•	•	•	•
SP5127	SmartSensor - AA001			•	•	•	•	•	•	•	•	•	•	•	•	•	•	•	•	•	•

Additional Anchoring Accessories Selection Guide Information

MAXSET Anchors

Stainless Steel	Galvanised	Anchor Weight
P105070	P105069	4kg/9lbs
P105055	P105000	6kg/13lbs
P105056	P105001	10kg/22lbs
P105057	P105002	16kg/35lbs
P105058	P105003	20kg/44lbs
P105059	P105004	25kg/55lbs
P105067	P105005	30kg/66lbs
P105068	P105006	40kg/88lbs

MAXCLAW Anchors

P105060	5kg/11lbs
P105061	7.5kg/17lbs
P105062	10kg/22lbs
P105063	15kg/33lbs
P105064	20kg/44lbs
P105065	30kg/66lbs
P105066	40kg/88lbs

MAXSET Bow Rollers

Polished Finish	Anchor Weight
P105075	4kg/9lbs
P105076	6kg/13lbs
P105077	10kg/22lbs
P105079	16kg/35lbs
P105081	20kg/44lbs
P105083	25kg/55lbs
P105083	30kg/66lbs
P105083	40kg/88lbs

Bow Rollers

P104330	Hinged # 1 up to 8mm (5/16") chain
P104331	Hinged # 2 up to 13mm (1/2") chain
P104332	Fixed # 1 up to 8mm (5/16") chain
P104333	Fixed # 2 up to 8mm (5/16") chain
P104334	Fixed # 3 up to 13mm (1/2") chain
P104340	Extendable hinged up to 13mm (1/2") chain
P104374	Fixed with anchor loop up to 13mm (1/2") chain

Chain Stoppers

P104335	Economy 8mm -10mm (5/16"-3/8") chain
P104372	Removable Levered Pawl 8mm (5/16") chain
P104373	Removable Levered Pawl 10mm (3/8") chain
P104374	Removable Levered Pawl 13mm (1/2") chain
P104358	Height Matched 8mm/10mm (5/16"-3/8") chain
P104359	Height Matched 10mm/13mm (3/8"-1/2") chain

Anchor Swivels

P104370	Stainless Steel 750 kg load 6mm-8mm (1/4"-5/16") chain
P104371	Stainless Steel 1500 kg load 10mm-13mm (3/8"-1/2") chain

Chain Snubbers and Tensioners

SP3174	Snubbing Hook 6/7mm (1/4") chain
SP3175	Snubbing Hook 8mm (5/16") chain
SP3176	Snubbing Hook 10mm (3/8") chain
P101100	Adjustable Devil's Claw/Tensioner 13mm (1/2") chain

Crank Handles

P103864	Short RC8, RC10 and RC12 windlasses
P103865	Long RC8, RC10 and RC12 windlasses

Installation and Maintenance

Maxwell provides a complete installation and maintenance manual with every windlass or capstan. This clear and detailed step-by-step guide, provides information on how and where to install your winch. Suggestions, practical tips and cautions provide a solid basis for usage and maintenance. These publications are available on the Maxwell website. A good installation could mean the difference between your winch performing as it should or ending up causing you problems. Please ensure that you carefully read the Owner's Manual before installing and using your winch. Simple guidelines and advice such as greasing the clutch cones, using products such as anti-corrosive and sealing spray on the motor and electrical terminals and bedding the winch to the deck with a top quality marine sealant will ensure that you get years of trouble free use from your Maxwell Marine products. If in doubt, contact your nearest Maxwell dealer.

Maxwell Three Year Warranty

Maxwell Marine provides a three year limited warranty on all windlasses, capstans and accessories for pleasure boat usage and a one year limited warranty for those systems used on commercial or charter vessels. Warranty, service and parts are available world-wide.

Contact your nearest Maxwell Marine office or check out the Maxwell Marine website:

www.maxwellmarine.com for a complete list of service centres, agents and distributors.



www.maxwellmarine.com

Maxwell's ongoing commitment to customer service and technological excellence can be viewed online at www.maxwellmarine.com.

This fully interactive and constantly evolving website features Maxwell's easy to use winch selection guide, cad drawings, product manual downloads and up-to-date technical information regarding the latest product developments and innovations.

You can register warranties on line, ask for technical advice, find out what boat shows we are attending and locate the Maxwell office, agent or distributor nearest you.

Glossary

Capstan Often referred to as a drum, rope drum, or warping drum. The capstan is primarily used for hauling rope.

Chain Stopper Similarly, chain compressor. Located between the winch and bow roller. Secures chain and anchor and takes the load off the winch/windlass. Highly recommended for systems utilising all chain and for semi-automatic rope and chain systems.

Free Fall Release of the winch clutch mechanism allowing the anchor and rode (chain or rope and chain) to run out freely with no engagement of winch gearbox or motor.

Gypsy Often referred to as chainwheel or wildcat. A special wheel with pockets, to accommodate a specified chain size, for hauling up the chain and anchor. With automatic rope/chain systems the gypsy is designed to haul both rope and chain.

Hauling Often referred to as weighing or lifting. The operation of lifting the anchor and rode.

Horizontal Pertaining to the winch or windlass. Drive shaft, capstan and gypsy are positioned horizontally to the deck.

Manual Override System Often referred to as emergency crank system. A means of manually cranking the winch to haul in the rode and anchor should a failure occur in the motor, gearbox or power supply.

Maximum Pull Sometimes referred to as rated lift, stall load, or simply lift/pull. The maximum pull or lift load of the winch.

Rode The line that secures the boat to the anchor. This may consist of all chain, all rope, or a combination of rope and chain.

Static Hold The maximum load that the windlass can hold. It is not recommended that the windlass be used in this manner.

Vertical Pertaining to the winch or windlass. The drive shaft, capstan and gypsy are positioned vertically to the deck.

Winch A windlass driven by a hand or power-operated crank or gearbox. Often implies to pull or lift a weight by using a winch.

Windlass A machine for raising a weight by winding a rope and/or chain around a drum or chainwheel, driven by a crank, motor, etc.

Working load Often referred to as the normal working load or the typical lift of the winch. This is usually somewhere between 25% to 35% of the maximum pull or rated lift. This workload should approximately correspond to the total weight of the anchor and rode aboard the boat.



Superyacht Windlasses and Capstans

For over four decades Maxwell Marine has been supplying anchoring solutions to the global marine market. The Superyacht industry poses unique challenges. Quality, reliability and style are a must. Owners and captains depend on the finest equipment aboard their luxurious vessels to see them safely around the world or cruising in their home waters. Maxwell Marine has become the manufacturer of choice on many of the world's Superyachts.

The 21st century has presented Maxwell Marine with new opportunities and challenges. Larger Superyachts mean larger windlasses and anchor handling equipment. In response Maxwell has continued to develop and expand its highly successful 'SY' Series Superyacht windlasses. Complemented by new and innovative deck gear, such as

integrated Roller-Stopper-Tensioners, Compressor-Roller-Tensioners and Chain Pipe-Rollers, Maxwell is able to meet the demands for a complete and integrated anchoring package for Megayachts.

All Superyacht products are manufactured to the stringent international requirements of ISO9001 and are covered under the European CE standard. Maxwell Superyacht products are, and can be, certified to any of the major classification societies such as Lloyds, DNV, ABS, BV, etc.

For more information about Maxwell Marine's extensive range of Superyacht products and services, see the Superyacht catalogue and information guide or visit www.maxwellmarine.com alternatively contact: superyacht@maxwellmarine.com.



RETRACTABLE VERTICAL CAPSTAN **RVC**

The Maxwell Retractable Vertical Capstan (RVC) has been designed not only for superb functionality, but with the aim that aesthetics aboard any yacht are also paramount. The top of the capstan drum is pleasing to the eye and has been patterned to provide a non-skid surface, when flush with the deck in the fully "DOWN" position, alternatively it can be recessed allowing for compatible deck finishes to be attached.



SY Series

Developed for vessels up to approximately 120 metres, the SY Series gives Maxwell the ability to offer customers highly competitive, top quality anchoring equipment, without over or under specifying power, strength, reliability or performance.

Developed and engineered in response to the demand for bigger and stronger anchor windlasses for today's larger Superyachts and Megayachts, Maxwell has once again set the standard for others to follow.







V-EQUIPMENT

The best equipment for your boat!

- High quality and reliability
- Complementary to the VETUS systems
- 3 Year warranty

BOAT SEATS

SEAT PEDESTALS

TABLES

DECK EQUIPMENT

FITTINGS

INFLATABLE BOATS

ANODES

AND MORE



ABYC-H-31 - SEAT STRUCTURE RECOMMENDATIONS

The ABYC-H-31 - Seat structure recommendations applies to permanently installed seats in cockpits, deck areas and all helm positions, including their fastenings and structures to which they are attached. It is a guide for the design, testing, construction and installations of these product systems.

These recommendations are divided into the so called type "A" and type "B" system.



Type "A" system

A seating system (seat and pedestal) designed for occupancy while vessel is underway at any boat speed.



Type "B" system

A seating system (seat and pedestal) designed for occupancy only at boat speed not exceeding 8 km/h (5 miles per hour).

The type "A" system is sub-divided into



Type "AO" operators system

Seat mounts must have a positive locking mechanism which shall withstand a torque of 205Nm (150 foot pounds). (Positive locking = by means of a pin lock)



Type "A" system

Seat mounts shall withstand a torque of 41Nm (30 foot pounds).



VETUS has symbolized these recommendations into the below mentioned classification logos, which are shown next to each individual seat mount within the VETUS comfort section of this catalogue.



Source: ABYC- H-31

Note

All seats are classified as type "A", a seat combined with a type "AO" seat mount is therefore usable as an operators system. A seat combined with a type "B" seat mount, has the above mentioned usage restrictions.

Boat seats

All seats and benches in this range are finished in maintenance free, water and UV resistant skai imitation leather, which is ideal for marine use. The skai imitation leather can also be ordered in rolls of 5 metres to match the complete boat interior to your boat seats. See page 354 for more information.

Equivalent RAL colours: White 9002, Dark Blue 5013, Cream 1015, with 12 more colours to special order.

Which pedestal?

Seats are supplied without pedestal. Please find the pedestal of your choice on page 355. The hole patterns (R or S) in the specification tables of the seat and pedestal should match. See the table on the right for the dimensions of the hole patterns.

Seat dimensions	Hole pattern (threaded)
	<p>R= (for slides)</p>
	<p>S= (for swivels)</p>



COMFORT



CHCOMW



CHCOMB

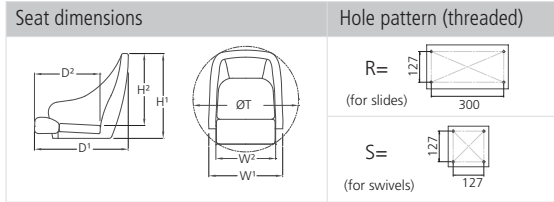

Commander

Luxurious chair with excellent support. The front part can be folded up for steering in a standing or leaning position.

Available colours:

- White (CHCOMW)
- Dark blue (CHCOMB)
- Without upholstery (CHCOMU)

Supplied without pedestal. Fits pedestals with slide only. Use seat cover CCDS or CCSB to keep the seat clean and protected against UV.

D1	D2	H1	H2	W1	W2	ØT	Hole pattern	Weight (lbs)
26 ⁵⁹ / ₆₄	18 ⁶⁵ / ₆₄	27 ⁹ / ₁₆	23 ¹³ / ₁₆	24 ⁵ / ₆₄	16 ¹ / ₃₂	28 ¹¹ / ₃₂	R	33



CHFUS



CHFUSBL

Queen

Comfortable FLIP-UP boat seat. The front part can be folded up for steering in a standing or leaning position.

Available colours:

- White (CHFUS)
- Dark blue (CHFUSBL)
- Without upholstery (CHFUSQU)

Supplied without pedestal. Fits pedestals with slide only. Use seat cover CCDS or CCSB to keep the seat clean and protected against UV.

D1	D2	H1	H2	W1	W2	ØT	Hole pattern	Weight (lbs)
28 ⁵ / ₃₂	19 ⁹ / ₆₄	23 ⁵ / ₈	20 ⁵ / ₆₄	22 ³ / ₆₄	18 ⁷ / ₆₄	31 ¹ / ₂	R	26.5



CHFUSW



CHFUSC



CHFUSB

King

Comfortable FLIP-UP boat seat. The front part can be folded up for steering in a standing or leaning position. With comfortable head rest.

Available colours:

- White with dark blue seams (CHFUSW)
- Dark blue with white seams (CHFUSB)
- Cream with cream seams (CHFUSC)
- Without upholstery (CHFUSKU)

Supplied without pedestal. Fits pedestals with slide only. Use seat cover CCDS or CCSB to keep the seat clean and protected against UV.

D1	D2	H1	H2	W1	W2	ØT	Hole pattern	Weight (lbs)
28 ¹¹ / ₃₂	19 ⁹ / ₆₄	24 ¹³ / ₃₂	19 ¹¹ / ₁₆	22 ⁷ / ₁₆	17 ²³ / ₃₂	31 ¹ / ₂	R	28.5





COMFORT



CHFASW



CHFASC



CHFASB

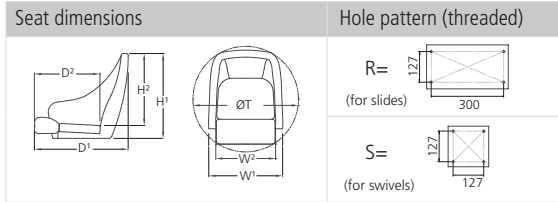

Master

High quality helm seat with armrests. Stainless steel frame (AISI 304).

Available colours:

- White (CHFASW)
- Dark blue (CHFASB)
- Cream (CHFASC)
- Without upholstery (CHFASU)

Supplied without pedestal. Fits pedestals with slide only. Use seat cover CCMB to keep the seat clean and protected against UV.

D1	D2	H1	H2	W1	W2	ØT	Hole pattern	Weight (lbs)
27 ¹¹ / ₆₄	19 ¹¹ / ₁₆	24 ³ / ₆₄	20 ³ / ₆₄	23 ² / ₆₄	20 ⁵ / ₆₄	29 ³⁹ / ₆₄	R	33

Sailor

Helm seat with armrests. Anodised aluminium frame.

Available colours:

- White (CHSAILW)
- Dark blue (CHSAILB)

Supplied without pedestal. Fits pedestals with slide only. Use seat cover CCDS or CCSB to keep the seat clean and protected against UV.

D1	D2	H1	H2	W1	W2	ØT	Hole pattern	Weight (lbs)
23 ³ / ₈	17 ² / ₆₄	24 ¹³ / ₃₂	21 ⁷ / ₆₄	22 ⁷ / ₁₆	16 ⁵⁹ / ₆₄	27 ⁹ / ₁₆	R	18



CHSAILW



CHSAILB

Skipper

Classic helm chair with comfortable arm rests. Anodised aluminium frame.

Available colours:

- White (CHCASW)
- Dark blue (CHCASB)

Supplied without pedestal. Fits all pedestals. Use seat cover CCDS or CCSB to keep the seat clean and protected against UV.

D1	D2	H1	H2	W1	W2	ØT	Hole pattern	Weight (lbs)
23 ¹⁵ / ₆₄	16 ⁷ / ₃₂	21 ¹ / ₁₆	16 ¹¹ / ₃₂	23 ² / ₆₄	16 ⁵⁹ / ₆₄	26 ⁶ / ₆₄	R / S	21



CHCASW



CHCASB



COMFORT



CHLIEUTB



CHLIEUTW



FLIP-UP

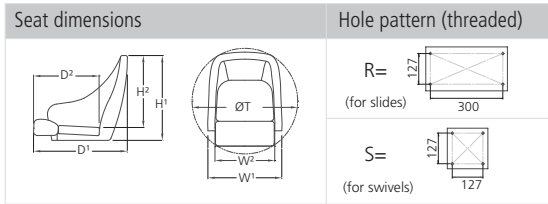

Lieutenant

Comfortable seat with a foldable front part for steering in standing or leaning positions.

- Available colours:
- White (CHLIEUTW)
 - Dark blue (CHLIEUTB)

Supplied without pedestal. Fits pedestals with slide only. Use seat cover CCDS or CCSB to keep the seat clean and protected against UV.

D1	D2	H1	H2	W1	W2	ØT	Hole pattern	Weight (lbs)
27 ⁶¹ / ₆₄	20 ³ / ₆₄	21 ¹⁷ / ₆₄	16 ⁹ / ₆₄	23 ¹ / ₃₂	16 ³⁹ / ₆₄	27 ⁶¹ / ₆₄	R	17.5



CHSPORTTB



CHSPORTW



FLIP-UP

CHSPORTWB

Pilot

Sporty seat with good lateral support. The front part can be folded up for steering in standing or leaning positions.

- Available colours:
- Black (CHSPORTTB)
 - White (CHSPORTW)
 - White with black (CHSPORTWB)
 - Without upholstery (CHSPORTU)

Supplied without pedestal. Fits pedestals with slide only. Use seat cover CCDS or CCSB to keep the seat clean and protected against UV.

D1	D2	H1	H2	W1	W2	ØT	Hole pattern	Weight (lbs)
26 ³ / ₈	18 ⁴⁵ / ₆₄	23 ³ / ₈	20 ³ / ₆₄	19 ¹¹ / ₁₆	15 ⁵⁹ / ₆₄	28 ¹¹ / ₃₂	R	17



CHDRIVEW



CHDRIVEWB

Driver

Sporty seat with good lateral support. Modern design.

- Available colours:
- White (CHDRIVEW)
 - White with black (CHDRIVEWB)

Supplied without pedestal. Fits pedestals with slide only. Use seat cover CCDS or CCSB to keep the seat clean and protected against UV.

D1	D2	H1	H2	W1	W2	ØT	Hole pattern	Weight (lbs)
25 ¹³ / ₆₄	17 ²⁹ / ₃₂	23 ³ / ₈	20 ³ / ₆₄	20 ¹⁵ / ₃₂	15 ⁵ / ₁₆	26 ³ / ₈	R	15.5





COMFORT



CHADMW



FLIP-UP



CHADMB

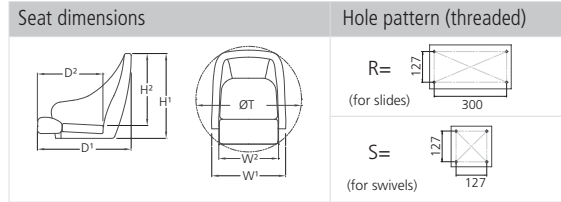

Admiral

A sporty and comfortable seat with lateral supports. The front part can be folded up for steering in standing or leaning positions.

- Available colours:
- White (CHADMW)
 - Dark blue (CHADMB)

Supplied without pedestal. Fits pedestals with slide only. Use seat cover CCDS or CCSB to keep the seat clean and protected against UV.

D1	D2	H1	H2	W1	W2	ØT	Hole pattern	Weight (lbs)
28 ^{7/64}	20 ^{3/64}	24 ^{3/32}	21 ^{1/32}	22 ^{5/64}	16 ^{59/64}	28 ^{49/64}	R	19



CHMAJORW



FLIP-UP



CHMAJORB

Major

A comfortable seat with a foldable front part for steering in standing or leaning positions.

- Available colours:
- White (CHMAJORW)
 - Dark blue (CHMAJORB)

Supplied without pedestal. Fits pedestals with slide only. Use seat cover CCDS or CCSB to keep the seat clean and protected against UV.

D1	D2	H1	H2	W1	W2	ØT	Hole pattern	Weight (lbs)
28 ^{47/64}	20 ^{3/64}	25 ^{3/64}	21 ^{7/32}	23 ^{3/32}	15 ^{3/4}	28 ^{47/64}	R	21



CHSEAMMB



Seaman

A roomy, classy and comfortable seat with a classic appearance. The front part can be folded up for steering in standing or leaning positions.

- Available colour:
- Mahogany brown (CHSEAMMB)

Supplied without pedestal. Fits pedestals with slide only. Use seat cover CCDS or CCSB to keep the seat clean and protected against UV.

D1	D2	H1	H2	W1	W2	ØT	Hole pattern	Weight (lbs)
23 ^{3/35}	20 ^{13/15}	24 ^{1/64}	19 ^{7/24}	23 ^{3/35}	17 ^{1/8}	28 ^{49/64}	R	30



COMFORT



CAPTSEAT3



CAPTCSL



CAPTCSB

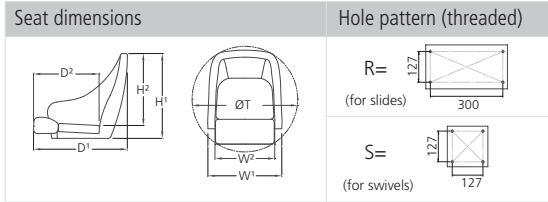

Captain

The CAPTSEAT3 is the well-known ergonomically shaped base seat without cushions. To make this seat complete a cushion set is available in two colours.

Cushions available in:

- Light grey with dark grey seams (CAPTCSL)
- Dark blue with light seams (CAPTCSB)

Supplied without pedestal. Fits pedestals with slide only. Use seat cover CCDS or CCSB to keep the seat clean and protected against UV.

Type	Description
CAPTSEAT3	Seat "Captain" in white without cushions
CAPTCSL	Cushion set for "Captain" seat light grey with dark grey seams
CAPTCSB	Cushion set for "Captain" seat navy blue with light seams

D1	D2	H1	H2	W1	W2	ØT	Hole pattern	Weight (lbs)
19 ³ / ₃₂	16 ⁵⁹ / ₆₄	19 ¹¹ / ₁₆	17 ²³ / ₃₂	20 ⁵⁵ / ₆₄	16 ⁵⁹ / ₆₄	20 ⁵⁵ / ₆₄	R	18



CHCS



CHCW



CHCBWB



CHCG

Crew

Deluxe light weight seat with folding back rest. With or without cushions.

Available colours:

- Light grey (without upholstery) (CHCS)
- White (CHCW)
- White with dark blue insert (CHCBWB)
- Grey (CHCG)



Supplied without pedestal.

Only fits pedestals without slide.

Use seat cover CCDS or CCSB to keep the seat clean and protected against UV.

D1	D2	H1	H2	W1	W2	ØT	Hole pattern	Weight (lbs)
18 ³ / ₃₂	17 ¹ / ₈	17 ¹ / ₈	15 ⁵ / ₁₆	18 ¹ / ₄	18 ¹ / ₄	24 ⁵ / ₆₄	S	6.5

Fisherman

Classic seat with folding back rest. Anodised aluminium hinges.

Available colours:

- White with dark blue seams (CHFSWW)
- Dark blue with white seams (CHFSBW)



Supplied without pedestal.

Fits all pedestals.

Use seat cover CCDS or CCSB to keep the seat clean and protected against UV.

D1	D2	H1	H2	W1	W2	ØT	Hole pattern	Weight (lbs)
18 ⁵⁷ / ₆₄	13 ²⁵ / ₃₂	17 ²³ / ₃₂	14 ¹¹ / ₆₄	15 ³ / ₄	15 ³ / ₄	22 ⁴¹ / ₆₄	R / S	7



CHFSWW



CHFSBW





COMFORT



CHFSW



CHFSB



CHFSL



CHFSD

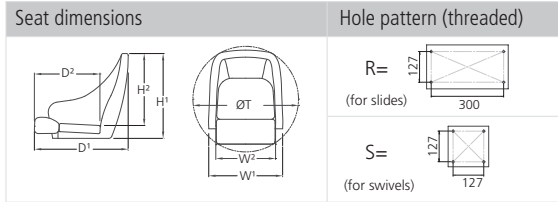

First Mate

Comfortable deluxe seat with folding back rest. Anodised aluminium hinges.

Available colours:

- White with blue seams (CHFSW)
- Dark blue with white seams (CHFSB)
- Light grey with dark grey seams (CHFSL)
- Grey with light grey seams (CHFSD)

Supplied without pedestal. Fits all pedestals.

Use seat cover CCDS or CCSB to keep the seat clean and protected against UV.



D1	D2	H1	H2	W1	W2	ØT	Hole pattern	Weight (lbs)
18 ⁵⁷ / ₆₄	13 ²⁵ / ₃₂	17 ²³ / ₃₂	14 ¹¹ / ₆₄	15 ³ / ₄	15 ³ / ₄	22 ⁴¹ / ₆₄	R / S	7



CHPRIVEL

Private seat

The trusted companion when it comes to fishing. Gives you support when needed, is small, lightweight and easy to clean.

Available colour:

- Light grey with dark grey seam (CHPRIVEL)

Supplied without pedestal. Fits pedestals with swivel only.

D1	D2	H1	H2	W1	W2	ØT	Hole pattern	Weight (lbs)
11 ¹⁵ / ₆₈	8 ⁴³ / ₆₅	5 ³⁷ / ₆₄	3 ²⁵ / ₁₆	15 ¹⁷ / ₂₇	14 ⁵⁵ / ₉₇	15 ³ / ₄	S	2.6



DCHFSW



DCHFSB

First Class

Comfortable deluxe double seat with folding back rest. Anodised aluminium hinges.

Available colours:

- White with dark blue seams (DCHFSW)
- Dark blue with white seams (DCHFSB)

Supplied without pedestal. Fits on two pedestals.

D1	D2	H1	H2	W1	W2	ØT	Hole pattern	Weight (lbs)
18 ⁵⁷ / ₆₄	13 ²⁵ / ₃₂	17 ²³ / ₃₂	14 ¹¹ / ₆₄	35 ⁷ / ₁₆	35 ⁷ / ₁₆	-	2xR	28.5



COMFORT



CHTBSW



CHTBSB

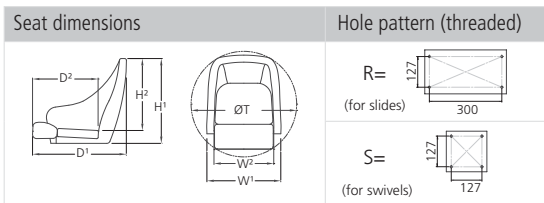

Ferry

Seat with moveable double sided backrest. Anodised aluminium hinges.

Available colours:

- White with dark blue seams (CHTBSW)
- Dark blue with white seams (CHTBSB)

Supplied without pedestal. Fits all pedestals.

Use seat cover CCDS or CCSB to keep the seat clean and protected against UV.

D1	D2	H1	H2	W1	W2	ØT	Hole pattern	Weight (lbs)
22 ⁷ / ₁₆	14 ⁴⁹ / ₆₄	18 ⁷ / ₆₄	14 ⁶¹ / ₆₄	16 ¹⁷ / ₃₂	16 ¹⁷ / ₃₂	27 ⁵¹ / ₆₄	R / S	13



DCHTBSW



DCHTBSB

Ferry Bench

Double seat with moveable double sided backrest. Anodised aluminium hinges.

Available colours:

- White with dark blue seams (DCHTBSW)
- Dark blue with white seams (DCHTBSB)

Supplied without pedestal. Fits on two pedestals (with or without slide).

D1	D2	H1	H2	W1	W2	ØT	Hole pattern	Weight (lbs)
22 ⁷ / ₁₆	14 ⁴⁹ / ₆₄	18 ⁷ / ₆₄	14 ⁶¹ / ₆₄	35 ⁷ / ₁₆	35 ⁷ / ₁₆	-	2xR / 2xS	33

Seat cover - weather proof

To keep the seat dry and clean and protected against UV. Made of nylon with PU coating. A drawstring is included.

Types CCDS and CCSB fit all single seats except the 'Master' seat.

Available colours:

- Dark blue
- Silver



CCDS



CCSB



CCMB

Type	D	H	W
CCDS / CCSB	19 ¹¹ / ₁₆	32 ⁴⁹ / ₆₄	25 ¹³ / ₆₄
CCMB*	22 ⁵³ / ₆₄	27 ⁹ / ₁₆	22 ⁵³ / ₆₄

* Type CCMB fits only the 'Master' seat (CHFAS..)

Available in

- Dark blue





COMFORT

Custom made - tailored fit

Freshen up your point of view

Would you like seats in different colours to the standard versions? Want to stand out from the crowd or trying to match the current upholstery? VETUS offers the solution: meet our custom made seat programme.

VETUS offers 15 colours of marine grade Skai imitation leather in the custom made seat programme. Simply select two or more of the un-upholstered seats from the custom made programme, pick your colour(s), and leave the rest to us! We can even embroider your logo if you wish. For existing boats we can also supply Skai by the roll, so the rest of your upholstery can be matched to your new seats. So whether you just want to change the existing colour scheme or are building a new boat, VETUS can be of assistance! The marine grade skai imitation leather is maintenance free, and water and UV resistant. Available in rolls of 4.4 feet (1.37 metre) width and 16 feet (5 metres) long.

Specifications

- 15 colours of marine grade imitation leather
- Carbon weave or regular finish available
- Optional embroidered logo

All seats are suitable for the custom seat programme, but the following un-upholstered seats are available from stock: Commander (CHCOMU), Queen (CHFUSQU), King (CHFUSKU), Master (CHFASU) and Pilot (CHSPORTU).

VETUS has 15 colours to choose from. For an overview of the available colours and their corresponding RAL number, please see below.

Type	Colour	RAL code
CHSKAIB	Dark blue	5013
CHSKAIW	White	9002
CHSKAIC	Cream	1015
Special order	Dark grey	7043
Special order	Light grey	7004
Special order	Pure white	9010
Special order	Ruby red	3003
Special order	Graphite black	9011

Type	Colour	RAL code
Special order	Golden yellow	1004
Special order	Emerald green	6001
Special order	Mahogany brown	8016
Special order	Sapphire blue	5003
Special order	Slate grey	7015
Special order	Aluminium white	9006
Special order	Traffic black	9017



S.CHSKAI

You can order S.CHSKAI as a sample set.

Colour combinations are possible as well. VETUS custom made seat programme is available to special order. Minimum order quantities for custom made upholstery are 2 of any seat type. Please ask for pricing.



Without upholstery



COMFORT

Seat pedestals

All pedestals are made of high grade aluminum and have a 360° rotatable swivel on top. Gas adjustable pedestals are operated with a handle. Manually adjustable pedestals have both a lock-pin with a locking position every 1" (25 mm) and a clamping knob for complete security. The sliding mechanism can be moved through 5³/₁₆ (135 mm) in total and locked in one of 7 positions.

Note

An explanation of the classification logo which is shown next to each seat mount can be found on page 346 of this catalogue.

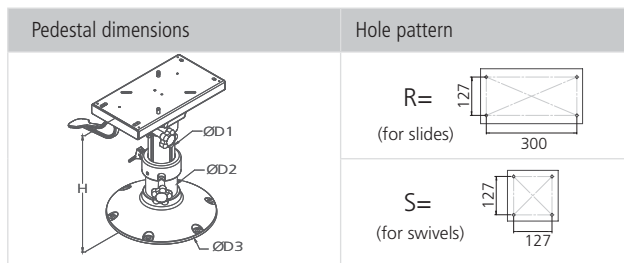

PCG3040

PCG3547

PCG4363

PCG5680

Gas adjustable pedestals with slide

For optimum enjoyment of your seat. Gas spring height adjustable aluminum seat pedestal with slide and 360° swivel. Polished base.

Type	Height (H)	Hole pattern	Pedestal Ø (D1 / D2)	Base Ø (D3)	Weight (lbs)
PCG3040	11 ³ / ₁₆ - 15 ³ / ₄	R / S	2 ¹ / ₈ / 3 ³ / ₁₆	8 ³ / ₃₂	13
PCG3547	13 ²⁹ / ₃₂ - 18 ¹ / ₄	R / S	2 ¹ / ₈ / 3 ³ / ₁₆	12 ¹ / ₁₆	15.5
PCG4363	17 ¹ / ₈ - 23 ¹⁹ / ₁₆	R / S	2 ¹ / ₈ / 3 ³ / ₁₆	12 ¹ / ₁₆	17
PCG5680	22 ¹ / ₁₆ - 31 ¹ / ₂	R / S	2 ¹ / ₈ / 3 ³ / ₁₆	12 ¹ / ₁₆	20



PCMS3040

PCMS3547

PCMS4363

Manually adjustable pedestals with slide

Manually height adjustable aluminum seat pedestal with slide and 360° swivel. Polished base.

Type	Height (H)	Hole pattern	Pedestal Ø (D1 / D2)	Base Ø (D3)	Weight (lbs)
PCMS3040	11 ³ / ₁₆ - 15 ³ / ₄	R / S	2 ¹ / ₈ / 3 ³ / ₁₆	8 ³ / ₃₂	13
PCMS3547	13 ²⁹ / ₃₂ - 18 ¹ / ₄	R / S	2 ¹ / ₈ / 3 ³ / ₁₆	12 ¹ / ₁₆	15.5
PCMS4363	17 ¹ / ₈ - 23 ¹⁹ / ₁₆	R / S	2 ¹ / ₈ / 3 ³ / ₁₆	12 ¹ / ₁₆	17



PCM3040

PCM3547

PCM4363

Manually adjustable pedestals without slide

Manually height adjustable aluminum seat pedestal with 360° swivel only. Anodised base.

Type	Height (H)	Hole pattern	Pedestal Ø (D1 / D2)	Base Ø (D3)	Weight (lbs)
PCM3040	11 ³ / ₁₆ - 15 ³ / ₄	S	2 ³ / ₁₆ / 2 ¹ / ₈	8 ³ / ₃₂	9
PCM3547	13 ²⁹ / ₃₂ - 18 ¹ / ₄	S	2 ³ / ₁₆ / 2 ¹ / ₈	8 ³ / ₃₂	6.5
PCM4363	17 ¹ / ₈ - 23 ¹⁹ / ₁₆	S	2 ³ / ₁₆ / 2 ¹ / ₈	8 ³ / ₃₂	12.5





COMFORT

Fixed height pedestals

With 360° swivel, available with or without slide. Anodised base.



Type	Slide	Height (H)	Hole pattern	Pedestal Ø (D2)	Base Ø (D3)	Weight (lbs)
PCFS33	✓	12 ^{5/16} / ₆₄	R / S	2 ^{7/8}	8 ^{31/32}	10
PCF33	-	12 ^{5/16} / ₆₄	S	2 ^{7/8}	8 ^{31/32}	
PCFS45	✓	17 ^{13/64} / ₆₄	R / S	2 ^{7/8}	8 ^{31/32}	10.5
PCF45	-	17 ^{13/64} / ₆₄	S	2 ^{7/8}	8 ^{31/32}	



PCFS33



PCF33



PCFS45



PCF45



FTREST

FTREST

Rotatable and foldable footrest for pedestals. Made from a marine grade aluminium with stainless steel fastenings. For extra grip the aluminium base plate has a diamond profile.

Type	Description	For pedestal Ø (D2)	Suits pedestal type	Weight (lbs)
FTREST73	Footrest	2 ^{7/8}	PCM, PCF	7.5
FTREST87	Footrest	3 ^{7/64}	PCMS, PCG	7.5

Does not fit type PCR nor PCQ pedestals.



PCBELL

Bell shape pedestal

A seat pedestal with a friction lock 360° swivel. The height is manually adjustable. Made from a marine grade aluminium. The large bell shaped base is grey powder coated.

Type	Height (H)	Hole pattern	Pedestal Ø (D1)	Base Ø (D3)	Weight (lbs)
PCBELL	12 ^{5/16} / ₆₄ - 16 ^{39/64} / ₆₄	S	2 ^{23/64}	2 ^{5/64}	5



PC13

Base with swivel

Low profile anodised base with 360° swivel.

Type	Height (H)	Hole pattern	Base Ø (D3)	Weight (lbs)
PC13	5 ^{9/32}	S	8 ^{31/32}	4.5



COMFORT



PCS15

Base with swivel and slide

Low profile anodised base with 360° swivel and slide.

Type	Height (H)	Hole pattern	Base Ø (D3)	Weight (lbs)
PCS15	153	R / S	228	4



PCBS

Swivel with slide

Aluminium 360° swivel with slide with 7 locking positions. For direct mounting.

Type	Height (H)	Hole pattern	Base Ø (D3)	Weight (lbs)
PCBS	2 ¹ / ₄	R / S	S	5.5
PCBSR	2 ¹ / ₄	R / S	S	5.5



PCBSR



PCBL

Rotatable base with locking position

Aluminium 360° rotatable base with 7 locking positions. For direct mounting.

Type	Height (H)	Hole pattern	Base	Weight (lbs)
PCBL	2 ¹ / ₄	S	S	4.5



PCB

Removable swivel base

Rotatable and removable plastic 360° swivel base for direct mounting.

Type	Height (H)	Hole pattern	Base	Weight (lbs)
PCB	2 ¹ / ₄	S	S	1.5

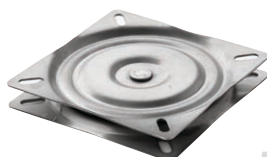

PCBR

Rotatable stainless steel base

360° Rotatable base for direct mounting. Made from stainless steel AISI 304.

Type	Height (H)	Hole pattern	Base	Weight (lbs)
PCBR	2 ⁹ / ₃₂	S	S	2





COMFORT



SCU

Slide

Seat slide for direct mounting. The sliding mechanism can be moved through 5⁵/₁₆" (135 mm) in total and locked in one of 7 positions.

Type	Height (H)	Hole pattern	Base	Weight (lbs)
SCU	2 ³ / ₄	R + S	S	4.5



PCR38



PCRS38

Removable pedestal (fixed height)

With 360° swivel or slide and recessed anodised base. Base and pedestal fit most commonly used similar systems in the market.

Type	Swivel (hole pattern)	Hight (H)	Pedestal Ø (D2)	Base Ø (D3)	Recessed depth	Hole Ø
PCR38	Swivel (S)	14 ⁶ / ₆₄	2 ²³ / ₆₄	8 ³¹ / ₃₂	2 ³ / ₄	3 ³⁵ / ₆₄
PCRS38	Slide (R)	14 ⁶ / ₆₄	2 ²³ / ₆₄	8 ³¹ / ₃₂	2 ³ / ₄	3 ³⁵ / ₆₄



PCRQ38

Removable pedestal

With 360° swivel and recessed anodised base. Base and pedestal fit most commonly used similar systems in the market.

Type	Swivel (hole pattern)	Hight (H)	Pedestal Ø (D2)	Base Ø (D3)	Recessed depth	Hole Ø
PCRQ33	Quick position (S)	12 ⁴² / ₆₄	2 ²³ / ₆₄	8 ³¹ / ₃₂	2 ³ / ₄	3 ³⁵ / ₆₄
PCRQ38	Quick position (S)	14 ⁶ / ₆₄	2 ²³ / ₆₄	8 ³¹ / ₃₂	2 ³ / ₄	3 ³⁵ / ₆₄



PCRQ33



PCRBASE

PCRBASE

This (spare) plug-in pedestal base can be used as an extra mounting position or as replacement for existing pedestal bases. The base is made of a marine grade anodized aluminium.



COMFORT

Quick positioning series seat pedestals

Pedestals in the quick positioning series are specially suitable for applications where multiple seating positions are used, such as in fishing boats. There are two positioning systems: a very quick click in system and a more sturdy threaded system. The components that form a complete pedestal can be ordered separately to offer great flexibility in seating configuration. Please make sure you order a swivel, leg and base to complete the pedestal. The quick release pedestals fit seats with hole pattern type S.



Quick positioning series swivel

Seat mount swivel with spring. Angled 3°. Outside dimension swivel: 6⁵/₈ x 6⁵/₈" (168 x 168 mm)

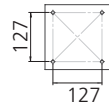

Type	Connection	Hole pattern	Height	Weight (lbs)
PCQSWIV	Click	S	5 ³ / ₆₄	1

Quick positioning series fixed height legs

Available with click or threaded connection. Anodised aluminium.

Type	Base Connection	Height (H)	Pedestal Ø	Weight (lbs)
PCQF28C	Click	11 ¹ / ₃₂	1 ⁴⁹ / ₆₄	1.3
PCQF28T	Threaded	11 ¹ / ₃₂	1 ⁴⁹ / ₆₄	1.6
PCQF33C	Click	12 ⁴³ / ₆₄	1 ⁴⁹ / ₆₄	1.4
PCQF33T	Threaded	12 ⁴³ / ₆₄	1 ⁴⁹ / ₆₄	1.7
PCQF38C	Click	14 ⁴¹ / ₆₄	1 ⁴⁹ / ₆₄	1.8
PCQF38T	Threaded	14 ⁴¹ / ₆₄	1 ⁴⁹ / ₆₄	1.9

Quick positioning series gas adjustable legs

Available with click or threaded connection. Angled 3°. 360° swivel included.

Type	Base Connection	Height (H)	Pedestal Ø	Hole pattern	Weight (lbs)
PCQG5774C	Click	22 ⁷ / ₁₆ - 29 ⁹ / ₆₄	1 ⁴⁹ / ₆₄	S	4.5
PCQG5774T	Threaded	22 ⁷ / ₁₆ - 29 ⁹ / ₆₄	1 ⁴⁹ / ₆₄	S	5

This adjustable pedestal contains chromed steel parts, we advise against use on salt water.

Quick positioning series baseplates

Stainless steel (AISI 316).

Type	Connection type	Base dimensions	Recessed depth	Hole Ø	Weight (lbs)
PCQBASEC	Click	6 ⁷ / ₃₂ X 6 ⁷ / ₃₂	2 ²³ / ₆₄	2 ¹¹ / ₆₄	2
PCQBASET	Threaded	6 ⁷ / ₃₂ X 6 ⁷ / ₃₂	3 ³⁹ / ₆₄	2 ¹¹ / ₆₄	2.5





COMFORT

Tables

All table tops are made from white synthetic material and have four cupholders incorporated. The table pedestals are high grade aluminium. The unique locking systems on the threaded base ensures a sturdy table. Separate base plates make various table positions on your boat possible.



Height adjustable table

Removable from the base. The screwed connection ensures a very sturdy table. Polished pedestal, anodised base.

Type	Top	Height	Base Ø	Max. load (lbs)
PTT5070	Oval, 17 ³¹ / ₃₂ X 29 ³¹ / ₆₄	19 ¹¹ / ₁₆ - 27 ⁹ / ₁₆	7 ¹ / ₆₄	48.5
TPM5070	Round, Ø 23 ³ / ₈	19 ¹¹ / ₁₆ - 27 ⁹ / ₁₆	7 ¹ / ₆₄	48.5



Fixed height table

Removable from the base. The screwed connection ensures a very sturdy table. Anodised aluminium.

Type	Top	Height	Base Ø	Max. load (lbs)
PTTF68	Oval, 17 ²³ / ₃₂ X 29 ³¹ / ₆₄	26 ³¹ / ₃₂	7 ¹ / ₆₄	48.5
PTF68	Round, Ø 23 ³ / ₈	26 ³¹ / ₃₂	7 ¹ / ₆₄	48.5



Quick remove table

Fixed height, easy to place and remove due to the countersunk connection to the base. Anodised aluminium.

Type	Top	Height	Base Ø	Recessed depth	Hole Ø	Max. load (lbs)
PTTR68	Oval, 17 ²³ / ₃₂ X 29 ³¹ / ₆₄	26 ³¹ / ₃₂	6 ⁴¹ / ₆₄	1 ³¹ / ₃₂	2 ³ / ₄	48.5
PTR68	Round, Ø 23 ³ / ₈	26 ³¹ / ₃₂	6 ⁴¹ / ₆₄	1 ³¹ / ₃₂	2 ³ / ₄	48.5

Table pedestals

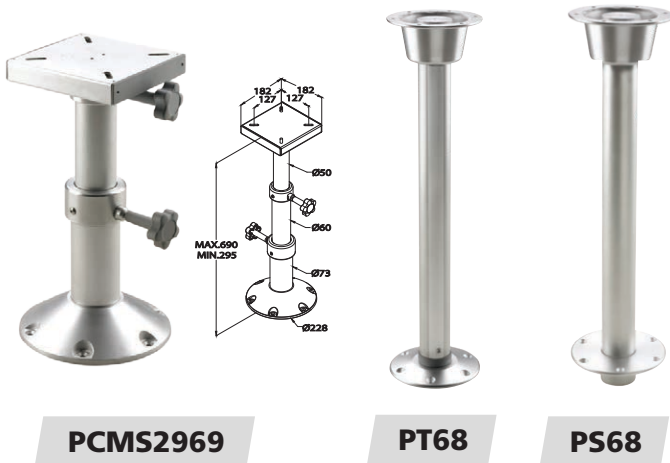

Telescopic pedestal

Two stage, height adjustable table pedestal. Anodised aluminium.

Type	Height	Base Ø	Max. load (lbs) Extended	Max. load (lbs) Retracted
PCMS2969	11 ³⁹ / ₆₄ - 27 ¹¹ / ₆₄	8 ³¹ / ₃₂	48.5	225

Removable pedestal

Fixed height, with screwed connection plate. Anodised base.

Type	Height	Base Ø
PT68	26 ³¹ / ₃₂	7 ¹ / ₆₄

Quick remove pedestal

Fixed height, with quick remove countersunk connection. Anodised aluminium.

Type	Height	Base Ø	Recessed depth	Hole Ø
PS68	26 ³¹ / ₃₂	6 ⁴¹ / ₆₄	1 ³¹ / ₃₂	2 ³ / ₄



COMFORT

Tables

These top quality parts and products in the VETUS table line are now available for a "mix and match to suit your needs". By having the choice to combine shape, size, options and finish we hope to cater to your needs in every possible situation. We guarantee that all choices are fit for combination and that the result will always be a sturdy, high quality product which is easy to install. The use of corrosion resistant materials will make sure that the combination of your choice will stand the test of time.

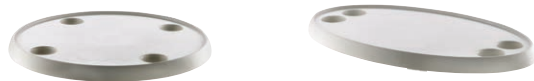

TTR

TTO



TB..

Table top

Made from white synthetic material. With four cupholders incorporated.

Type	Top
TTR	Round, Ø 23 ³ / ₈
TTO	Oval, 17 ³ / ₃₂ X 29 ³ / ₆₄

Swivel for table top

Type	Description
TBT	Table swivel anodised aluminium
TBTBA	Table swivel bright anodised aluminium



TCCA

TCSA

TCSP

TCSPM

TCSPG

TCCP

Table post

The table posts are made of high grade aluminium. Available in fixed- or adjustable heights.

Type	Description	Height
TCCA	Table post with tapered ends, anodized	26 ³ / ₃₂
TCCP	Table post with tapered ends, polished	26 ³ / ₃₂
TCSA	Table post with screw connection, anodized	26 ³ / ₃₂
TCSP	Table post with screw connection, polished and bright anodised	26 ³ / ₃₂
TCSPM	Table post with screw connection, polished and bright anodised, manually adjustable	19 ¹¹ / ₁₆ - 27 ⁹ / ₁₆
TCSPG	Table post with screw connection, polished and bright anodised, gas adjustable	19 ¹¹ / ₁₆ - 27 ⁹ / ₁₆



TBF



TBR

TBFBA

TBRBA

Base

These (spare) bases can be mounted directly on the deck. In addition to being part of the "mix and match" programme they can also be used as an extra table position or as replacement for existing pedestal bases. The bases are made of a marine grade anodized aluminium. The TBR and TBRBA have a unique locking system to ensure a sturdy table system.

Type	Description	Connection	Base Ø	Recessed depth	Hole Ø	Weight (lbs)
TBF	Anodised	Countersunk	6 ⁷ / ₆₄	1 ³ / ₃₂	2 ³ / ₆₄	1
TBFBA	Bright anodised	Countersunk	6 ⁷ / ₆₄	1 ³ / ₃₂	2 ³ / ₆₄	1
TBR	Anodised	Screw down	7 ¹ / ₆₄	-	-	0,8
TBRBA	Bright anodised	Screw down	7 ¹ / ₆₄	-	-	0,8



DECK EQUIPMENT



H12 **H24**
H12D **H24D**

Electric marine horns

Electric marine horns made of stainless steel (AISI 316). Available in 12 or 24 Volt and with high and/or low pitch sound.

Type	Horns	Pitch	Vol.	Length	Height	Width
H12L	1	Low	115 dB	18 ¹ / ₄	4 ¹⁷ / ₃₂	7 ⁹ / ₆₄
H12H	1	High	115 dB	18 ¹ / ₄	4 ¹⁷ / ₃₂	7 ⁹ / ₆₄
H24L	1	Low	115 dB	18 ¹ / ₄	4 ¹⁷ / ₃₂	3 ⁴⁷ / ₆₄
H24H	1	High	115 dB	18 ¹ / ₄	4 ¹⁷ / ₃₂	3 ⁴⁷ / ₆₄
H12D	2	High + Low	115 dB	15 ³ / ₄	4 ¹⁷ / ₃₂	3 ⁴⁷ / ₆₄
H24D	2	High + Low	115 dB	15 ³ / ₄	4 ¹⁷ / ₃₂	3 ⁴⁷ / ₆₄



T12

Flush mount electric horns

Flush mounted electric horns. Plastic housing, stainless steel (AISI 316) diaphragm. Available in 12 Volt. Includes white, black and chrome plated ABS cover.

Type	Vol.	Cover Length	Cover Height	Build in depth
T12	110 dB	5 ³ / ₆₄	2 ⁷ / ₁₆	3 ⁴⁷ / ₆₄



TNA12 **TNA24**

Compact electric horns

Deluxe compact electric horns. Horn made of chromium plated ABS and stainless steel (AISI 316). Available in 12 or 24 Volt and with high pitch and/or low pitch sound. Supplied with relay.

Type	Horns	Pitch	Freq. (Hz)	Vol.	Length	Height	Width
TNA12L	1	Low	420	115 dB	3 ¹³ / ₁₆	4 ³¹ / ₆₄	3 ⁴⁷ / ₆₄
TNA12H	1	High	480	115 dB	3 ¹³ / ₁₆	4 ³¹ / ₆₄	3 ⁴⁷ / ₆₄
TNA24L	1	Low	420	115 dB	3 ¹³ / ₁₆	4 ³¹ / ₆₄	3 ⁴⁷ / ₆₄
TNA24H	1	High	480	115 dB	3 ¹³ / ₁₆	4 ³¹ / ₆₄	3 ⁴⁷ / ₆₄
TNA12D	2	High + Low	Both	115 dB	7 ⁹ / ₆₄	4 ³¹ / ₆₄	3 ⁴⁷ / ₆₄
TNA24D	2	High + Low	Both	115 dB	7 ⁹ / ₆₄	4 ³¹ / ₆₄	3 ⁴⁷ / ₆₄



DECK EQUIPMENT



C12L



C12D

Compact shell horns

Electric horns. Stainless steel (AISI 316). Available in 12 Volt.

Type	Horns	Pitch	Vol.	Length	Height	Width
C12L	1	Low	110 dB	3 ¹⁷ / ₆₄	2 ¹³ / ₆₄	4 ³ / ₃₂
C12D	2	High + low	110 dB	5 ⁵ / ₆₄	2 ¹³ / ₆₄	3 ¹¹ / ₃₂

Push-button for marine horn

This push button may operate marine horns, with a current consumption of 15 A maximum. Suitable for 12 and 24 Volt D.C. electrical installations.



HORNPB

Specifications

- Cut-out diameter: Ø 1⁷/₃₂" (31 mm)
- Outside dimensions: Ø 1¹/₂" (38 mm)
- Watertight to IP67

Type	Description
HORNPB	Horn push button, max 15A, 12/24 Volt

Boarding ladders (AISI 316)

All ladders are made of high-gloss polished stainless steel (AISI 316).



SLT3A

SLT4A

Telescopic ladder

Stainless steel (AISI 316). Available with 3 or 4 steps and in 2 different widths. With synthetic black grips.

Type	Steps	L (extended)	L (retracted)	Width (c to c)*	Tube Ø	Weight (lbs)	Max. load (lbs)
SLT3A	3	34 ²¹ / ₃₂	14 ³ / ₄	10	3/4 / 63/64 / 1 ¹⁷ / ₆₄	5,9	661
SLT4A	4	45 ⁷ / ₈	15 ⁵ / ₁₆	10	3/4 / 63/64 / 1 ¹⁷ / ₆₄ / 1 ¹ / ₂	7,9	661
SLT3AW	3	34 ¹ / ₄	14 ³ / ₄	14	3/4 / 63/64 / 1 ¹⁷ / ₆₄	6,3	661
SLT4AW	4	45 ²¹ / ₃₂	16 ¹¹ / ₃₂	14	3/4 / 63/64 / 1 ¹⁷ / ₆₄ / 1 ¹ / ₂	8,8	661

* c to c means distance between tube centers





DECK EQUIPMENT



SLT3PA

SLT4PA

Telescopic platform cassette ladder

Stainless steel (AISI 316). Available with 3 or 4 steps. With synthetic black grips.

Type	Steps	L (extended)	L (retracted)	Width (c to c)*	Tube Ø	Weight (lbs)	Max. load (lbs)
SLT3PA	3	34 ⁷ / ₁₆	14 ⁹ / ₁₆	10	3/4 / 63/64 / 1 ¹⁷ / ₆₄	7,9	661
SLT4PA	4	45 ⁷ / ₈	16 ¹¹ / ₃₂	10	3/4 / 63/64 / 1 ¹⁷ / ₆₄ / 1 ¹ / ₂	11,2	661

* c to c means distance between tube centers



SLT4CA

Telescopic cassette ladder

High gloss polished stainless steel (AISI 316). Available with 4 steps. With black synthetic grips.

Type	Steps	L (extended)	L (retracted)	Width (c to c)*	Tube Ø	Weight (lbs)	Max. load (lbs)
SLT4CA	4	45 ²¹ / ₃₂	0	10	3/4 / 63/64 / 1 ¹⁷ / ₆₄ / 1 ¹ / ₂	17,6	661

* c to c means distance between tube centers



SLFB3A

SLFB4A



Folding ladder, deck mounted

Stainless steel (AISI 316). Available with 3 or 4 steps with synthetic black grips.

Type	Steps	L (extended)	L (retracted)	Width (c to c)*	Tube Ø	Weight (lbs)	Max. load (lbs)
SLFB3A	3	26 ³¹ / ₂₁	14 ³ / ₄	9	5/8	1,8	385
SLFB4A	4	36 ⁷ / ₃₂	21 ²¹ / ₃₂	9	5/8	5,0	385

* c to c means distance between tube centers



DECK EQUIPMENT



SLT4DA

Luxury swim ladder

Telescopic swim ladder with 4 steps. Stainless steel (AISI 316). With black synthetic grips.

Heavy duty stainless steel construction with a L-angle bracket for extra support that goes across the edge of a deck. This luxury ladder extends 44⁷/₈" (1140 mm) below the deck when it is unfolded.

- The handrails help you to climb on board easily
- The steps are covered with black synthetic grips to give extra safety with bare feet

Type	Steps	L (extended)	L (retracted)	Width (c to c)*	Tube Ø	Weight (lbs)	Max. load (lbs)
SLT4DA	4	63	18 ²⁹ / ₃₂	14	3/4 / 63/64 / 1 ¹⁷ / ₆₄ / 1 ¹ / ₂	18,7	661

* c to c means distance between tube centers



SLF3A

SLF4A

Folding ladder, transom mounted

Stainless steel (AISI 316). Available with 3 or 4 steps. With synthetic black grips.

Type	Steps	L (extended)	L (retracted)	Width (c to c)*	Tube Ø	Weight (lbs)	Max. load (lbs)
SLF3A	3	24 ¹⁹ / ₃₂	13	9	55/64	9,0	385
SLF4A	4	35 ⁵ / ₈	17 ¹⁷ / ₃₂	9	55/64	11,4	385

* c to c means distance between tube centers



SLFM3

Folding ladder with teak steps

Stainless steel (AISI 316). Available with 3 or 4 steps in teak.

Type	Steps	L (extended)	L (retracted)	Width (c to c)*	Tube Ø	Weight (lbs)	Max. load (lbs)
SLFM3	3	22 ⁷ / ₈	11 ¹³ / ₃₂	6	55/64	3,3	385
SLFM4	4	29 ²⁹ / ₃₂	18 ¹¹ / ₁₆	6	55/64	4,1	385

* c to c means distance between tube centers



SLFM4





DECK EQUIPMENT

Handrail (AISI 316)



PIJP



STEUN..

Stainless steel (AISI 316) handrail

Rail pipe and rail fittings available in $\text{Ø } 25/32''$ (20 mm) and 1" (25 mm). Pipe is available per metre. Fittings must be ordered separately, please see price list.

Type	Tube Ø	Wall thickness	Max. pipe length
PIJP	$25/32$	$1/16$	$326/32$
PIJP25	$63/64$	$1/16$	$326/32$

Type	Tube Ø	Support
STEUN20V	$25/32$	Front
STEUN20A	$25/32$	Rear
STEUN20M	$25/32$	Middle
STEUN25V	$63/64$	Front
STEUN25A	$63/64$	Rear
STEUN25M	$63/64$	Middle

Stainless steel (AISI 316) stanchions

Tapered with 2 wire holes.

Specifications

- Diameter: 1" (25 mm)
- Length: $24\frac{1}{64}$ and $29\frac{17}{32}$ (610 and 750 mm)



STANCH..

Type	Length	Ø	Hole spacing
STANCH61	$24\frac{1}{64}$	1	2 wire holes at $12\frac{1}{64}$ / $23\frac{3}{8}$
STANCH75	$29\frac{17}{32}$	1	2 wire holes at $14\frac{49}{64}$ / $29\frac{9}{64}$

Stainless steel (AISI 316) stanchion sockets

Specifications

- Diameter: 1" (25 mm)
- 90° straight or with 6° angle
- Dimensions (lxwxh): $3\frac{9}{16}'' \times 2\frac{5}{8}'' \times 2\frac{3}{8}''$ (90 x 67 x 60 mm)



STANCHPR



STANCHPS

Type	Description
STANCHPR	Straight
STANCHPS	Angled 6°



DECK EQUIPMENT

Cleats and bollards



TAURUS

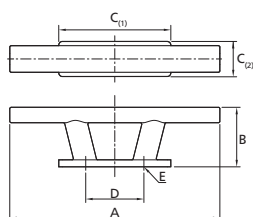

Cleats type TAURUS

All models (except TAURUS06 and 07) are tapped on the underside so that no fastenings are visible. Made of high-gloss polished stainless steel (AISI 316).

Type	SWL*	A	B	C	D	E
TAURUS01	575 kgf	5 ³¹ / ₆₄	1 ³¹ / ₃₂	3 ¹⁷ / ₃₂ X 1 ³ / ₁₆	1 ²⁷ / ₃₂	2 x M8
TAURUS02	900 kgf	7 ⁴³ / ₆₄	2 ²³ / ₆₄	4 ³ / ₄ X 1 ³ / ₈	2 ²³ / ₃₂	2 x M10
TAURUS03	1310 kgf	10 ³ / ₆₄	2 ⁶¹ / ₆₄	5 ²⁹ / ₃₂ X 1 ³⁷ / ₆₄	3 ¹⁷ / ₆₄	2 x M12
TAURUS04	2470 kgf	11 ¹³ / ₁₆	3 ¹¹ / ₃₂	6 ¹⁹ / ₆₄ X 1 ³¹ / ₃₂	3 ¹⁷ / ₆₄	2 x M16
TAURUS05	2470 kgf	11 ¹³ / ₁₆	3 ¹¹ / ₃₂	7 ¹ / ₈ X 3 ¹¹ / ₃₂	3 ¹⁷ / ₆₄	2 x M16
TAURUS06**	2620 kgf	11 ¹³ / ₁₆	3 ¹¹ / ₃₂	7 ¹ / ₈ X 3 ¹¹ / ₃₂	5 ¹ / ₈ X 2 ¹¹ / ₆₄	4 x Ø 1/2
TAURUS07***	3600 kgf	9 ²⁷ / ₃₂	2 ⁷ / ₄	9 ²⁷ / ₃₂ X 1 ³⁷ / ₆₄	4 ⁹ / ₆₄	3 x Ø 1/2

* SWL = Safe working load

** 4 holes in a rectangle as dimensioned by D. Holes are 90° countersunk.

*** 3 holes in line with 4⁹/₆₄" (105 mm) in between. Holes are 90° countersunk.



ACHIL



ACHILZ

ACHIL090B

Bollards type ACHIL

Made of high-gloss polished stainless steel (AISI 316).

Bollards type ACHILZ are for direct welding to the deck. Dimensions are similar to ACHIL.

Type	SWL*	A	B	Ø	C**	D	E
ACHIL080	620 kgf	4 ²² / ₃₂	3 ³⁵ / ₆₄	1 ³¹ / ₃₂	3 ⁵ / ₃₂ X 2 ⁹ / ₁₆	2 ³ / ₆₄	4 x Ø 1/4
ACHIL090	620 kgf	5 ¹ / ₈	3 ⁴⁷ / ₆₄	1 ³¹ / ₃₂	3 ⁵ / ₈ X 3 ⁵ / ₈	2 ³ / ₆₄	4 x Ø 1/4
ACHIL110	1150 kgf	6 ¹⁹ / ₆₄	4 ²³ / ₃₂	2 ²³ / ₆₄	4 ³¹ / ₆₄ X 3 ¹³ / ₁₆	2 ³ / ₄	4 x Ø 1/4
ACHIL130	1150 kgf	7 ³ / ₃₂	5 ¹⁹ / ₃₂	2 ⁷ / ₄	5 ⁵³ / ₆₄ X 4 ⁴¹ / ₆₄	3 ¹⁵ / ₆₄	4 x Ø 5/16
ACHIL150	1800 kgf	7 ¹ / ₈	6 ⁴⁹ / ₆₄	3 ⁵ / ₃₂	6 ¹ / ₃₂ X 4 ⁵¹ / ₆₄	3 ¹⁵ / ₁₆	4 x Ø 13/32
ACHIL160	2620 kgf	10 ³ / ₆₄	7 ⁴³ / ₆₄	3 ³⁵ / ₆₄	6 ¹ / ₂ X 5 ⁵ / ₁₆	4 ²³ / ₃₂	4 x Ø 1/2
ACHIL080Z	620 kgf	4 ²² / ₃₂	3 ⁵ / ₃₂	1 ³¹ / ₃₂	-	1 ³¹ / ₃₂	-
ACHIL090Z	620 kgf	5 ¹ / ₈	3 ⁹ / ₁₆	1 ³¹ / ₃₂	-	1 ²⁷ / ₃₂	-
ACHIL110Z	1150 kgf	6 ¹⁹ / ₆₄	4 ⁵ / ₁₆	2 ²³ / ₆₄	-	2 ³ / ₈	-
ACHIL130Z	1150 kgf	7 ³ / ₃₂	5 ¹ / ₈	2 ⁷ / ₄	-	2 ³ / ₄	-
ACHIL150Z	1800 kgf	7 ¹ / ₈	5 ²⁹ / ₃₂	3 ⁵ / ₃₂	-	3 ¹⁵ / ₁₆	-
ACHIL160Z	2620 kgf	10 ³ / ₆₄	6 ⁵ / ₁₆	3 ³⁵ / ₆₄	-	4 ²³ / ₃₂	-

Type	Description
ACHIL090B	Bollard type Achilles 90, with bolt mounting

Bollard type ACHIL090B for small craft is fastened by means of two M8 bolts. Dimensions are similar to ACHIL090.

* SWL = Safe working load

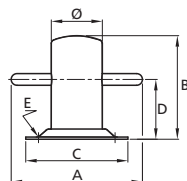



DECK EQUIPMENT

Rubbing strakes

Configure rubbing strakes that really suit your style and vessel. Choose the desired base profile, select you favorite top profile and cap it off with one of our stylish end caps. Personalising your boat has never been this easy!

HARO

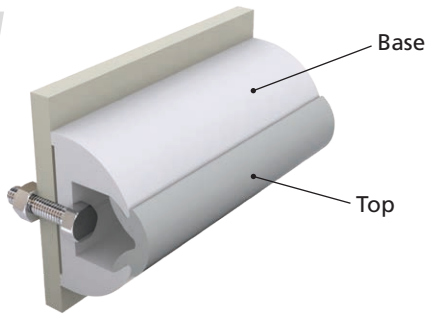

HARO5S

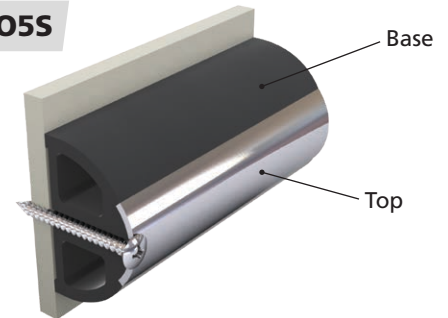

HARO5034

HARO6035

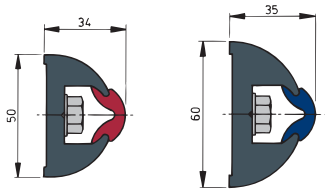

HARO5S



Base profile

Type	Color	Dimension	Length (metres)
HARO5034	Dark grey	1 ³¹ / ₃₂ X 1 ¹¹ / ₃₂	20
HARO5034L	Dark grey	1 ³¹ / ₃₂ X 1 ¹¹ / ₃₂	30
HARO50W	White	1 ³¹ / ₃₂ X 1 ¹¹ / ₃₂	20
HARO50WL	White	1 ³¹ / ₃₂ X 1 ¹¹ / ₃₂	30
HARO6035	Dark grey	2 ²³ / ₆₄ X 1 ³ / ₈	20
HARO6035L	Dark grey	2 ²³ / ₆₄ X 1 ³ / ₈	30
HARO60W	White	2 ²³ / ₆₄ X 1 ³ / ₈	20
HARO60WL	White	2 ²³ / ₆₄ X 1 ³ / ₈	30



Base profile

Type	Color	Dimension	Length (metres)
HARO5S	Dark grey	1 ³¹ / ₃₂ X 1 ¹¹ / ₃₂	20
HARO5SL	Dark grey	1 ³¹ / ₃₂ X 1 ¹¹ / ₃₂	30
HARO5SW	White	1 ³¹ / ₃₂ X 1 ¹¹ / ₃₂	20
HARO5SWL	White	1 ³¹ / ₃₂ X 1 ¹¹ / ₃₂	30

Top profile PVC

Type	Color	Length (metres)	Type	Color	Length (metres)
STRIPB	Cobalt blue	20	STRIPG	Light grey	20
STRIPBL	Cobalt blue	30	STRIPGL	Light grey	30
STRIPD	Dark grey	20	STRIPR	Wine red	20
STRIPDL	Dark grey	30	STRIPRL	Wine red	30



End caps PVC

Type	Description
EHARO50B	Set end pieces black for rubbing strake type HARO50
EHARO50W	Set end pieces white for rubbing strake type HARO50
EHARO60B	Set end pieces black for rubbing strake type HARO60
EHARO60W	Set end pieces white for rubbing strake type HARO60



Top profile stainless steel

Type	Description
HARO20S	Stainless steel inlay, 10 x 2 mtr. lengths
HARO30S	Stainless steel inlay, 15 x 2 mtr. lengths



End caps stainless steel

Type	Description
HAROSE	Set of 2 stainless steel end pieces for rubbing strake type HARO5S





DECK EQUIPMENT



TRAP

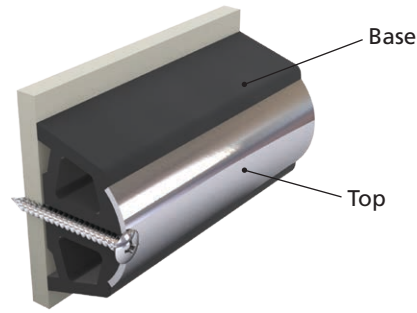
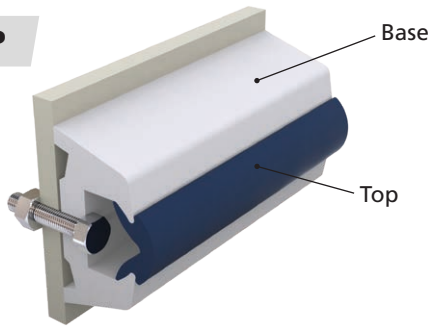

TRAP5534

TRAP6038

TRAP7043

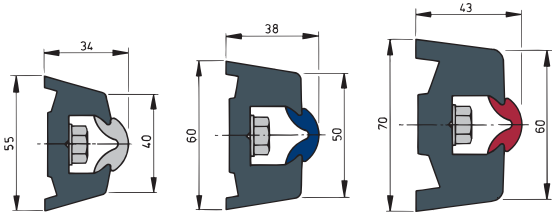

TRAP55

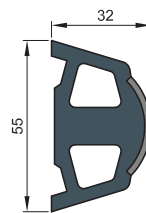

Base profile

Type	Colour	Dimension	Length (metres)
TRAP5534	Dark grey	2 ¹¹ / ₆₄ x 1 ¹¹ / ₃₂	20
TRAP5534L	Dark grey	2 ¹¹ / ₆₄ x 1 ¹¹ / ₃₂	30
TRAP55W	White	2 ¹¹ / ₆₄ x 1 ¹¹ / ₃₂	20
TRAP55WL	White	2 ¹¹ / ₆₄ x 1 ¹¹ / ₃₂	30
TRAP6038	Dark grey	2 ²³ / ₆₄ x 1 ¹ / ₂	20
TRAP6038L	Dark grey	2 ²³ / ₆₄ x 1 ¹ / ₂	30
TRAP60W	White	2 ²³ / ₆₄ x 1 ¹ / ₂	20
TRAP60WL	White	2 ²³ / ₆₄ x 1 ¹ / ₂	30
TRAP7043	Dark grey	2 ³ / ₄ x 1 ¹¹ / ₁₆	20
TRAP7043L	Dark grey	2 ³ / ₄ x 1 ¹¹ / ₁₆	30
TRAP70W	White	2 ³ / ₄ x 1 ¹¹ / ₁₆	20
TRAP70WL	White	2 ³ / ₄ x 1 ¹¹ / ₁₆	30



Base profile

Type	Colour	Dimension	Length (metres)
TRAP55	Dark grey	2 ¹¹ / ₆₄ x 1 ¹¹ / ₃₂	20
TRAP55L	Dark grey	2 ¹¹ / ₆₄ x 1 ¹¹ / ₃₂	30
TRAP55W	White	2 ¹¹ / ₆₄ x 1 ¹¹ / ₃₂	20
TRAP55WL	White	2 ¹¹ / ₆₄ x 1 ¹¹ / ₃₂	30

Top profile PVC

Type	Color	Length (metres)	Type	Color	Length (metres)
STRIPB	Cobalt blue	20	STRIPG	Light grey	20
STRIPBL	Cobalt blue	30	STRIPGL	Light grey	30
STRIPD	Dark grey	20	STRIPR	Wine red	20
STRIPDL	Dark grey	30	STRIPRL	Wine red	30



End caps PVC

Type	Description
ETRAP55B	Set end pieces black for rubbing strake type TRAP55
ETRAP55W	Set end pieces white for rubbing strake type TRAP55
ETRAP60B	Set end pieces black for rubbing strake type TRAP60
ETRAP60W	Set end pieces white for rubbing strake type TRAP60
ETRAP70B	Set end pieces black for rubbing strake type TRAP70
ETRAP70W	Set end pieces white for rubbing strake type TRAP70



Top profile stainless steel

Type	Description
TRAP205	Stainless steel inlay, 10 x 2 mtr. lengths
TRAP305	Stainless steel inlay, 15 x 2 mtr. lengths

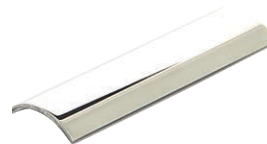

End caps stainless steel

Type	Description
TRAPSE	Set of 2 stainless steel end pieces for rubbing strake type TRAP55





DECK EQUIPMENT

Rubbing strake, ideal for GRP boats

POLY

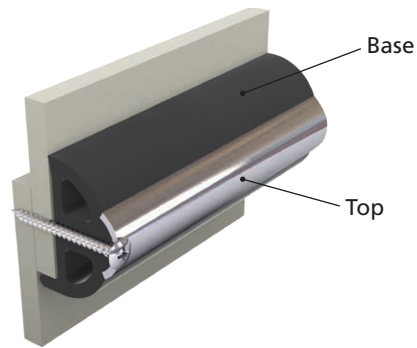
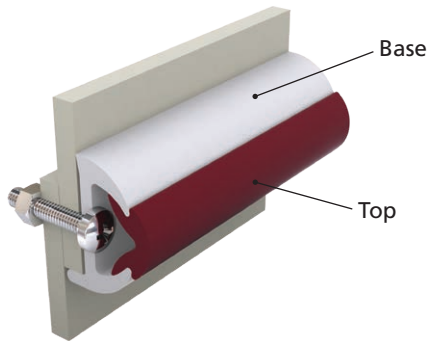

POLY3026

POLY3528

POLY4031

POLY4S

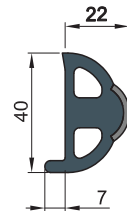
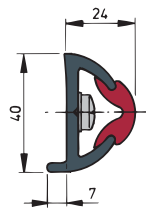
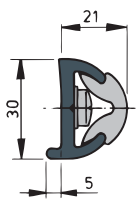

Base profile

Type	Color	Dimension	Length (metres)
POLY3026	Dark grey	1 ³ / ₁₆ X 1 ¹ / ₃₂	20
POLY3026L	Dark grey	1 ³ / ₁₆ X 1 ¹ / ₃₂	30
POLY30W	White	1 ³ / ₁₆ X 1 ¹ / ₃₂	20
POLY30WL	White	1 ³ / ₁₆ X 1 ¹ / ₃₂	30
POLY3528	Dark grey	1 ³ / ₈ X 1 ⁷ / ₆₄	20
POLY3528L	Dark grey	1 ³ / ₈ X 1 ⁷ / ₆₄	30
POLY35W	White	1 ³ / ₈ X 1 ⁷ / ₆₄	20
POLY35WL	White	1 ³ / ₈ X 1 ⁷ / ₆₄	30
POLY4031	Dark grey	1 ³ / ₁₆ X 1 ⁷ / ₃₂	20
POLY4031L	Dark grey	1 ³ / ₁₆ X 1 ⁷ / ₃₂	30
POLY40W	White	1 ³ / ₁₆ X 1 ⁷ / ₃₂	20
POLY40WL	White	1 ³ / ₁₆ X 1 ⁷ / ₃₂	30



Base profile

Type	Color	Dimension	Length (metres)
POLY4S	Dark grey	1 ³ / ₁₆ X 1 ⁷ / ₃₂	20
POLY4SL	Dark grey	1 ³ / ₁₆ X 1 ⁷ / ₃₂	30
POLY4SW	White	1 ³ / ₁₆ X 1 ⁷ / ₃₂	20
POLY4SWL	White	1 ³ / ₁₆ X 1 ⁷ / ₃₂	30

Top profile stainless steel

Type	Description
POLY20S	Stainless steel inlay, 10 x 2 mtr. lengths
POLY30S	Stainless steel inlay, 15 x 2 mtr. lengths

Top profile PVC

Type	Color	Length (metres)	Type	Colour	Length (metres)
STRIPB	Cobalt blue	20	STRIPG	Light grey	20
STRIPBL	Cobalt blue	30	STRIPGL	Light grey	30
STRIPD	Dark grey	20	STRIPR	Wine red	20
STRIPDL	Dark grey	30	STRIPRL	Wine red	30



End caps PVC

Type	Description
EPOLY40B	Set end pieces black for rubbing strake type POLY40
EPOLY40W	Set end pieces white for rubbing strake type POLY40
EPOLY30B	Set end pieces black for rubbing strake type POLY30
EPOLY30W	Set end pieces white for rubbing strake type POLY30
EPOLY35B	Set end pieces black for rubbing strake type POLY35
EPOLY35W	Set end pieces white for rubbing strake type POLY35



End caps stainless steel

Type	Description
POLYSE	Set of 2 stainless steel end pieces for rubbing strake type POLY4S

DECK EQUIPMENT

Rubbing strake for steel boats

STE4838

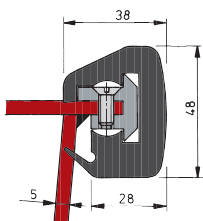
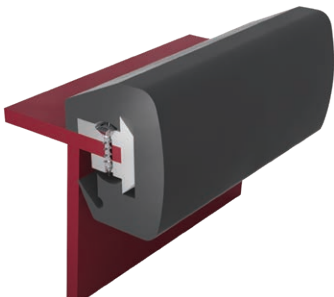

Base profile

Type	Color	Dimension	Length (metres)
STE4838	Dark grey	1 ⁵⁷ / ₆₄ x 1 ¹ / ₂	20
STE4838L	Dark grey	1 ⁵⁷ / ₆₄ x 1 ¹ / ₂	30



Top profile PVC

Type	Color	Length (metres)	Type	Color	Length (metres)
STRIPB	Cobalt blue	20	STRIPG	Light grey	20
STRIPBL	Cobalt blue	30	STRIPGL	Light grey	30
STRIPD	Dark grey	20	STRIPR	Wine red	20
STRIPDL	Dark grey	30	STRIPRL	Wine red	30

End caps PVC

Ask for the possibilities.

ROND4248

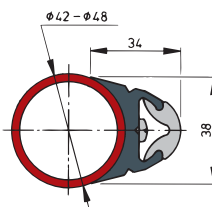
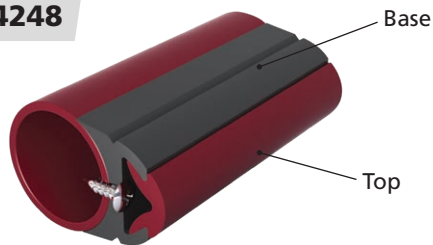

Base profile

Type	Color	Dimension	Length (metres)
ROND4248	Dark grey	Round 1 ²¹ / ₃₂ - 1 ⁵⁷ / ₆₄	20
ROND4248L	Dark grey	Round 1 ²¹ / ₃₂ - 1 ⁵⁷ / ₆₄	30



Top profile stainless steel

Ask for the possibilities.



End caps stainless steel

Ask for the possibilities.





DECK EQUIPMENT

Searchlights

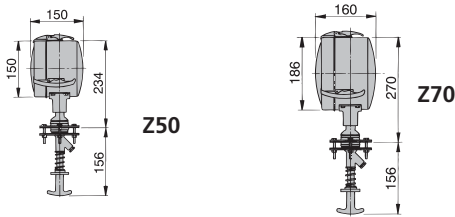

Stainless steel (AISI 316) searchlights type Z

Stainless steel AISI 316. Including sealed beam.

Type	Ø	Voltage	Watts	Range
Z5012	5 ^{9/32}	12 V	100 W	1476 ft
Z5024	5 ^{9/32}	24 V	250 W	1804 ft
Z7012	7 ^{3/32}	12 V	100 W	1558 ft
Z7024	7 ^{3/32}	24 V	170 W	1575 ft

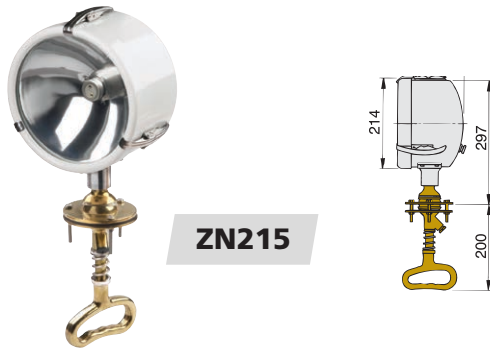

Powder coated search light type ZN

Bulbs should be ordered seperately.

Type	Ø	Bulb	Voltage	Watts	Range
ZN215	8 ^{27/64}	HAL21512	12 V	100 W	396 ft
ZN215	8 ^{27/64}	HAL21524	24 V	250 W	2178 ft
ZN215	8 ^{27/64}	HAL215220	230 V AC	300 W	1132 ft

Navigation lights



In order to comply with the I.M.O. regulations, each navigation light (type 35 or type 55N) requires a special focussed 25 W bulb, type LAMP1225 (12 V) or LAMP2425 (24 V). These bulbs must be ordered separately.



LAMP1225

LAMP2425

Type	Description
LAMP1225	Bulb for navigation lights 12 Volt/25 Watt (approved)
LAMP2425	Bulb for navigation lights 24 Volt/25 Watt (approved)



DECK EQUIPMENT

Navigation lights type 35

Black or white housing. Meets I.M.O. Specifications (international regulations for prevention of collisions at sea, colreg '72). For boats of less than 66 ft (20 metres) in length.

Available in this range:

Side mounting, base mounting or hoistable. Light images as shown on the right.

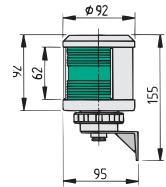

Type	Description
SB35ZWIT	Starboard light (side mounting), with white coloured housing (excl. bulb)
BB35ZWIT	Portside light (side mounting), with white coloured housing (excl. bulb)
TW35ZWIT	Steaming light (side mounting), with white coloured housing (excl. bulb)
HW35ZWIT	Stern light (side mounting), with white coloured housing (excl. bulb)
TKL35VWIT	Bicolour light (base mounting), with white coloured housing (excl. bulb)
DKL35VWIT	Tricolour light (base mounting), with white coloured housing (excl. bulb)
RW35VWIT	All round, white (base mounting), with white coloured housing (excl. bulb)
RR35VWIT	All round, red (base mounting), with white coloured housing (excl. bulb)
RG35VWIT	All round, green (base mounting), with white coloured housing (excl. bulb)
RW35HWIT	All round, white (hoistable), with white coloured housing (excl. bulb)
RR35HWIT	All round, red (hoistable), with white coloured housing (excl. bulb)
RGR35HWIT	All round, green (hoistable), with white coloured housing (excl. bulb)

Type	Description
SB35Z	Starboard light (side mounting), with black coloured housing (excl. bulb)
BB35Z	Portside light (side mounting), with black coloured housing (excl. bulb)
TW35Z	Steaming light (side mounting), with black coloured housing (excl. bulb)
HW35Z	Stern light (side mounting), with black coloured housing (excl. bulb)
TKL35V	Bicolour light (base mounting), with black coloured housing (excl. bulb)
DKL35V	Tricolour light (base mounting), with black coloured housing (excl. bulb)
RW35V	All round, white (base mounting), with black coloured housing (excl. bulb)
RR35V	All round, red (base mounting), with black coloured housing (excl. bulb)
RG35V	All round, green (base mounting), with black coloured housing (excl. bulb)
RW35H	All round, white (hoistable), with black coloured housing (excl. bulb)
RR35H	All round, red (hoistable), with black coloured housing (excl. bulb)
RGR35H	All round, green (hoistable), with black coloured housing (excl. bulb)

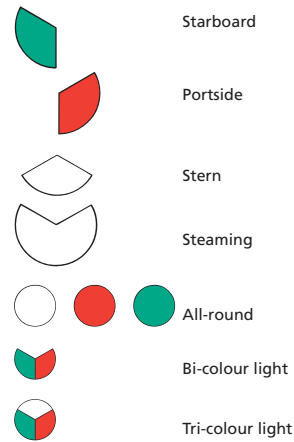

Navigation lights type 55N

Black housing. Model 55N not only meets the above mentioned I.M.O. specifications, but also those of the European standard EN 14744, which will become applicable in future. For the all round lights, a set is available that allows them to be hoisted as well. For boats of less than 164 ft (50 metres) in length.

Available in this range:

Base mounting or hoistable. Light images as shown on the right.

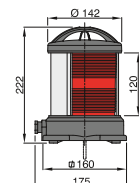

Type	Description
SB55VN	Starboard light (base mounting), with black coloured housing (excl. bulb)
BB55VN	Portside light (base mounting), with black coloured housing (excl. bulb)
TW55VN	Steaming light (base mounting), with black coloured housing (excl. bulb)
HW55VN	Stern light (base mounting), with black coloured housing (excl. bulb)
HGL55VN	Towing light, yellow (base mounting), with black coloured housing (excl. bulb)
RW55VN	All round, white (base mounting), with black coloured housing (excl. bulb)
RR55VN	All round, red (base mounting), with black coloured housing (excl. bulb)
RGL55VN	All round, yellow (base mounting), with black coloured housing (excl. bulb)
RGR55VN	All round, green (base mounting), with black coloured housing (excl. bulb)
SETH55	Set to make navigation lights type 55 hoistable

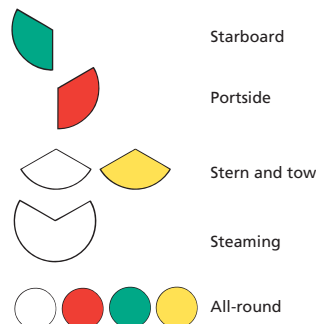



MARINE FITTINGS

V-Quipment marine fittings are designed for reliability and made of high grade materials. Failure of submerged fittings can cause major problems, therefore we advise the use of stainless steel (AISI 316) or bronze fittings (ISO CuPb5Sn5Zn5) for applications in which the fittings are in continuous contact with salt water.

Stainless steel (AISI 316) Marine fittings

Water scoop

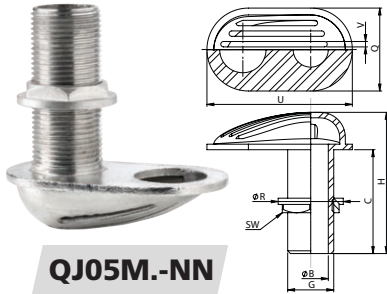

QJ05M.-NN

Type	Thread (G)* inches	ØB	H	C	Q	ØR	SW	U	V	Weight (lbs)
QJ05MC-NN	3/8"	11	90	66	44	26	22	81	2	0.44
QJ05MD-NN	1/2"	12	88	65	44	32	25	81	2	0.55
QJ05ME-NN	3/4"	19	107	82	56	41	32	104	3	0.88
QJ05MF-NN	1"	26	105	76	60	47	38	106	3.2	0.99
QJ05MG-NN	1 1/4"	33	103	78	64	57	49	116	3.5	1.21
QJ05MH-NN	1 1/2"	39	108	82	70	72	53	133	3.5	1.61
QJ05MI-NN	2"	51	122	91	86	83	68	152	3.6	2.20

*According to ISO 228/1-G..B

Air vent

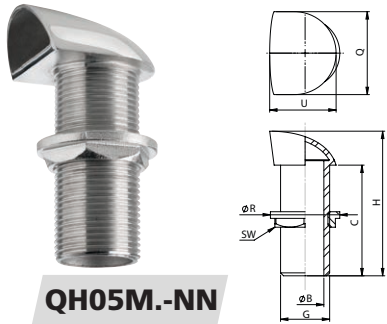

QH05M.-NN

Polished surface, without flame arrester gauze.

Type	Thread (G)* (inches)	ØB	H	C	Q	ØR	SW	U	Weight (lbs)
QH05MD-NN	1/2"	16	83	65	38	32	25	38	0.29
QH05ME-NN	3/4"	21	86	65	43	41	32	41	0.37
QH05MF-NN	1"	27	98	75	50	47	38	58	0.57
QH05MG-NN	1 1/4"	36	108	79	57	57	49	65	0.88
QH05MH-NN	1 1/2"	42	114	82	64	72	53	75	1.10
QH05MI-NN	2"	53	134	89	81	83	68	97	2.10

*According to ISO 228/1-G..B

Hose connector with male thread

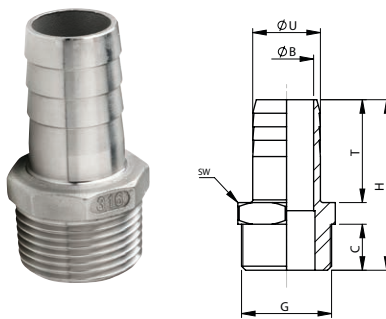

QA05M.-..

Type	Thread (G) (inches)	ØU	ØB	H	C	T	Weight (lbs)
QA05MC-15	3/8"	15	11	50,2	14,5	28	0.07
QA05MD-12	1/2"	12	7	64	19	36	0.20
QA05MD-15	1/2"	15	11	54	14,5	31	0.09
QA05MD-20	1/2"	20	14	58	15	32	0.13
QA05ME-20	3/4"	20	15,5	60	17	35,5	0.15
QA05ME-25	3/4"	25	20	63	17	37	0.20
QA05MF-25	1"	25	20,5	67	19	39,5	0.26
QA05MF-30	1"	30	25	70	19	43	0.31
QA05MG-32	1 1/4"	32	27	76	21	45	0.37
QA05MG-35	1 1/4"	35	29,5	76	20,5	45	0.44
QA05MG-38	1 1/4"	38	32	78	21,5	48	0.44
QA05MH-38	1 1/2"	38	33,5	81,5	22	48	0.90
QA05MH-45	1 1/2"	45	39	86	22	52,5	0,55
QA05MI-50	2"	50	44	98,6	26	59,5	0,90

Hose connector with female thread

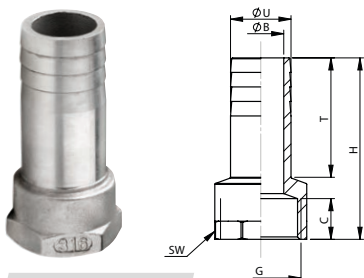

QA05F.-..

Type	Thread (G)* (inches)	ØU	ØB	H	C	T	Weight (lbs)
QA05FC-15	3/8"	15	10	41	11,5	26,5	0.09
QA05FD-15	1/2"	15	10	48	15,5	27	0.13
QA05FD-20	1/2"	20	15	48	15,5	30	0.13
QA05FE-20	3/4"	20	14	56	16	34	0.20
QA05FF-25	1"	25	18,5	63	19	37,5	0.31
QA05FG-35	1 1/4"	35	28	69	21	42	0.66
QA05FG-40	1 1/4"	40	34	69	21	42	0.71
QA05FH-45	1 1/2"	45	38	76	21,5	50	0.90
QA05FI-50	2"	50	42	90,5	24	59,5	1.12

*According to ISO 228/1-G..



MARINE FITTINGS

Hose connector 90° bend with female thread

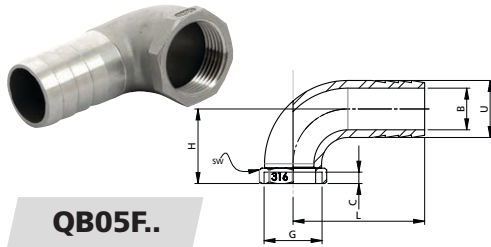

QB05F..

Type	Thread (G) inches	C	U	B	L	H	SW	Weight (lbs)
QB05FD-19	1/2"	11	19	15	48	21	27	0,19
QB05FE-25	3/4"	11	25	19	57	26	32	0,33
QB05FF-30	1"	13	30	24	65	30	35	0,53
QB05FH-39	1 1/2"	16	39	35	84	50	50	1,03
QB05FH-44	1 1/2"	16	50	43	84	50	50	1,32

Hose connector 90° bend with male thread

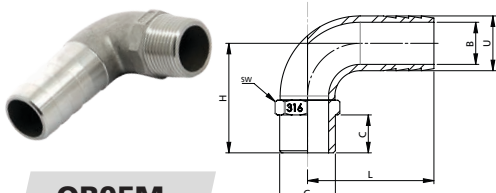

QB05M..

Type	Thread (G) inches	C	U	B	L	H	SW	Weight (lbs)
QB05MD-20	1/2"	15	20	15	54	39	23	0,24
QB05ME-25	3/4"	17	25	19	66	46	29	0,41
QB05MF-30	1"	18	30	24	73	51	35	0,59
QB05MG-38	1 1/4"	21	38	31	82	57	44	0,83

Thru-hull - Chamfered

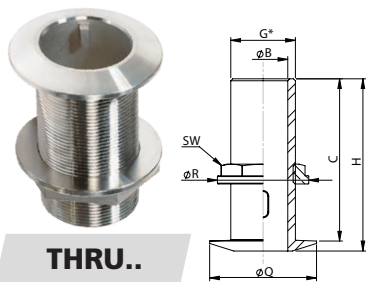

THRU..

Machined surface

Type	Thread (G) (inches)	ØB	H	C	ØQ	ØR	SW	Weight (lbs)
THRU1/2S	1/2"	15	60	52	46	34	27	0,33
THRU3/4S	3/4"	20	72	63	51	47	36	0,55
THRU1S	1"	26	79	71	54	54	42	0,77
THRU11/4S	1 1/4"	33	86	77	70	68	53	1,43
THRU11/2S	1 1/2"	39	97	88	70	72	60	1,32
THRU2S	2"	52	109	101	88	88	74	1,98

*According to ISO 228/1-G..B

Thru-hull - Rounded

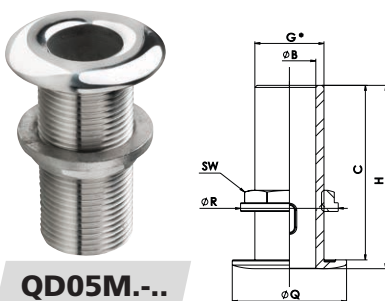

QD05M-..

Polished surface

Type	Thread (G)* (inches)	ØB	H	C	ØQ	ØR	SW	Weight (lbs)
QD05MC-NN	3/8"	11	57	53	35	26	22	0,18
QD05MD-NN	1/2"	15	63	59	39	32	25	0,22
QD05ME-NN	3/4"	20	75	70	49	41	32	0,49
QD05MF-NN	1"	25	79	73	55	47	38	0,57
QD05MG-NN	1 1/4"	35	84	79	63	57	49	0,77
QD05MH-NN	1 1/2"	40	84	79	71	72	53	1,10
QD05MI-NN	2"	52	101	97	85	83	68	1,65

*According to ISO 228/1-G..B

Thru-hull - Rounded with hose connection

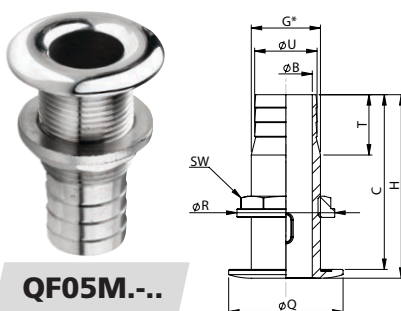

QF05M-..

Polished surface

Type	Thread (G)* (inches)	ØB	H	C	ØQ	ØR	SW	T	ØU	Weight (lbs)
QF05MC-14	3/8"	11	59	55	35	26	22	20	14	0.18
QF05MD-18	1/2"	15	65	60	39	32	25	24	18	0.24
QF05ME-23	3/4"	20	75	71	49	41	32	24	23	0.39
QF05MF-29	1"	25	79	73	54	47	38	30	29	0.53
QF05MG-38	1 1/4"	35	85	80	63	57	49	30	38	0.66
QF05MH-44	1 1/2"	40	87	81	71	72	53	30	44	0.97
QF05MI-55	2"	52	100	95	85	83	68	40	55	1.43

*According to ISO 228/1-G..B



MARINE FITTINGS

Thru-hull - Flush

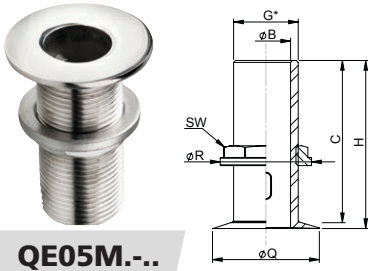

QE05M-...

Polished surface

Type	Thread (G)* (inches)	ØB	H	C	ØQ	ØR	SW	Weight (lbs)
QE05MC-NN	3/8"	11	54	51	32	26	22	0.15
QE05MD-NN	1/2"	15	62	58	37	32	25	0.22
QE05ME-NN	3/4"	20	72	66	48	41	32	0.44
QE05MF-NN	1"	26	76	70	55	47	38	0.55
QE05MG-NN	1 1/4"	34	79	73	64	57	49	0.77
QE05MH-NN	1 1/2"	38	81	76	70	72	53	1.10
QE05MI-NN	2"	50	89	84	81	83	68	1.65

*According to ISO 228/1-G..B

Thru-hull - Flush with hose connection

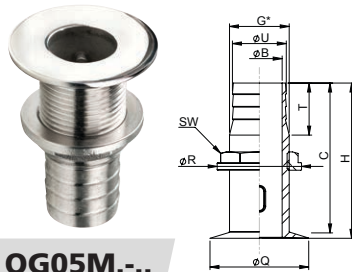

QG05M-...

Polished surface

Type	Thread (G) (inches)	ØB	H	C	ØQ	ØR	SW	T	ØU	Weight (lbs)
QG05MC-15	3/8"	11	54	51	33	26	22	23	15	0.15
QG05MD-18	1/2"	15	62	58	37	32	25	24	18	0.18
QG05ME-22	3/4"	20	71	65	48	41	32	27	22	0.35
QG05MF-29	1"	26	76	70	56	47	38	28	29	0.55
QG05MG-38	1 1/4"	34	79	73	64	57	49	30	38	0.66
QG05MH-43	1 1/2"	38	82	76	69	72	53	35	43	0.99
QG05MI-55	2"	50	89	84	81	83	68	40	55	1.54

Ball valves



BV..

In a number of countries it is a legal requirement that the toilet or holding tank outlet can be locked to prevent the accidental discharge of black water in port. These stainless steel (AISI 316) ball valves can be padlocked if required. The padlock itself is not supplied. Suitable for diesel oil, gasoline, water and sea water.

Type	Thread (G)* (inches)	Thread length	Bore	Normal Press (bar)	Working temp (° C)	Dimensions hxbxd	Weight (lbs)
BV1/2	1/2"	14	Full Bore	69	-20 - +160	130x65x35	0.66
BV3/4	3/4"	16	Full Bore	69	-20 - +160	150x80x40	1.10
BV1	1"	19	Full Bore	69	-20 - +160	160x85x50	1.76
BV11/4	1 1/4"	19	Full Bore	69	-20 - +160	195x110x60	2.54
BV11/2	1 1/2"	20	Full Bore	69	-20 - +160	230x125x70	4.19
BV2	2"	22	1 59/64	69	-20 - +160	260x140x80	5.73

*According to ISO 228/1-G..

Bronze Marine fittings (ISO CuPb5Sn5Zn5)

Water scoop

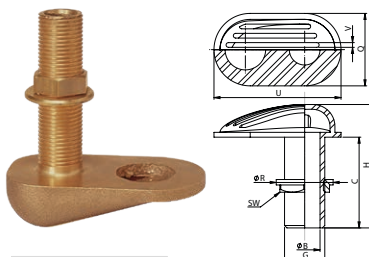

WCAPB

Type	Thread (G)* (inches)	ØB	H	C	Q	ØR	SW	U	V	Weight (lbs)
WCAPB1/2	1/2"	15	96	73	50	38	25	91	4	0.75
WCAPB3/4	3/4"	19	102	78	58	48	32	103	4	1.10
WCAPB1	1"	25	109	83	61	53	39	106	4	1.34
WCAPB11/4	1 1/4"	35	117	90	65	64	50	118	4	1.65
WCAPB11/2	1 1/2"	38	129	100	70	70	55	131	4	2.09

*According to ISO 228/1-G..B



MARINE FITTINGS

Thru-hull - Chamfered

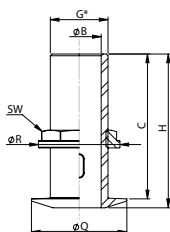

THRUUB

Type	Thread (G)* (inches)	ØB	H	C	ØQ	ØR	SW	Weight (lbs)
THRUUB1/2	1/2"	15	64	59	39	38	25	0.33
THRUUB3/4	3/4"	19	70	65	48	48	32	0.51
THRUUB1	1"	26	77	47	54	54	40	0.71
THRUUB11/4	1 1/4"	34	82	76	65	64	49	0.99
THRUUB11/2	1 1/2"	38	84	79	70	70	55	1.21

*According to ISO 228/1-G..B

Hose connector with male thread

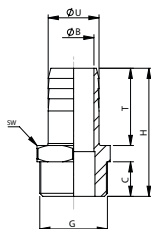

HPB

Type	Thread (G) (inches)	ØU	ØB	H	C	SW	T	Weight (lbs)
HPB1/2	1/2"	13	10	51	13	23	30	0.13
HPB3/4	3/4"	20	15	53	14	28	32	0.18
HPB1	1"	25	20	62	15	36	38	0.37
HPB11/4	1 1/4"	31	26	67	16	45	42	0.55
HPB11/2	1 1/2"	37	32	72	18	52	45	0.66

Manifolds



MAN.G

VETUS fluid manifolds enable a number of pipes to be connected to a single thru-hull fitting. These manifolds are made of seawater resistant bronze (ISO CuZn35Al1). They may also be connected to an underwater skin fitting with ball valve for raw water intake. It is not recommended to connect multiple engines or generating sets to one raw water intake.

Type	Main connections (M/F) (G)* (inches)	Connections (F) (G)* (inches)
MAN2G1/2	3/4"	2 x 1/2"
MAN3G1/2	3/4"	3 x 1/2"
MAN2G3/4	1"	2 x 3/4"
MAN3G3/4	1"	3 x 3/4"

Ball valves

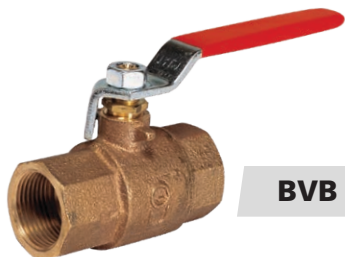

BVB

Bronze ISO CuPb5Sn / CuSn5Zn5Pb5

Type	Thread (G)* Female	Bore	Working Press (bar)	Working temp. (°C)	Dimensions hxbxd	Weight (lbs)
BVB1/2	1/2"	Full Bore	32	-10 - +120	120x60x40	0.62
BVB3/4	3/4"	Full Bore	32	-10 - +120	140x70x40	0.84
BVB1	1"	Full Bore	32	-10 - +120	150x80x50	1.32
BVB11/4	1 1/4"	Full Bore	32	-10 - +120	175x98x60	2.09
BVB11/2	1 1/2"	Full Bore	32	-10 - +120	180x110x75	2.87

*According to ISO 228/1-G..





MARINE FITTINGS

Brass Marine fittings

For continuous immersion in salt water, we advise against the use of brass fittings.

Water scoop**

WCAP

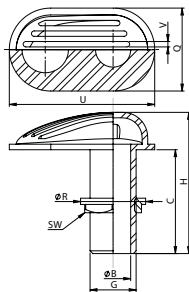

Type	Thread (G)* (inches)	ØB	H	C	Q	ØR	SW	U	V	Weight (lbs)
WCAP1/2	1/2"	15	96	72	49	38	26	91	3	0.66
WCAP3/4	3/4"	19	103	77	58	48	32	105	3	0.99
WCAP1	1"	26	104	76	61	55	38	108	3	1.21
WCAP11/4	1 1/4"	26	104	78	61	55	38	108	3	1.43
WCAP11/2	1 1/2"	39	113	82	72	72	56	134	3	1.98
WCAP2	2"	51	126	91	89	88	68	156	3	3.31
WCAP21/2	2 1/2"	65	155	112	113	113	92	198	5	5.29
WCAP3	3"	77	134	134	129	120	105	238	5	8.60

*According to ISO 228/1-G..B

** For continuous immersion in salt water, we advise against the use of brass fittings.

Thru-hull - Chamfered**

DOORB

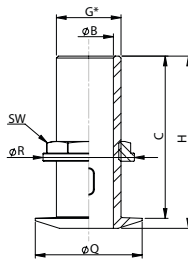

Machined surface

Type	Thread (G)* (inches)	ØB	H	C	ØQ	ØR	SW	Weight (lbs)
DOORB3/8	3/8"	11	58	53	34	36	22	0.44
DOORB1/2	1/2"	15	64	58	40	39	25	0.55
DOORB3/4	3/4"	19	72	66	49	49	32	0.55
DOORB1	1"	25	77	70	56	56	40	0.77
DOORB11/4	1 1/4"	34	83	76	65	66	50	0.99
DOORB11/2	1 1/2"	39	84	78	72	72	56	1.32
DOORB2	2"	50	102	94	84	84	68	1.98
DOORB21/2	2 1/2"	65	132	123	110	111	91	3.75
DOORB3	3"	76	150	140	127	124	105	5.51

*According to ISO 228/1-G..B

** For continuous immersion in salt water, we advise against the use of brass fittings.

Hose connector angled**

HPM

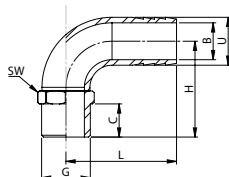
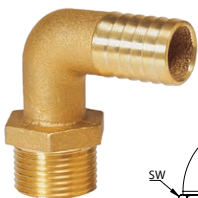

Type	Thread (G) (inches)	ØU	ØB	H	C	SW	L	Weight (lbs)
HPM1/2B	1/2"	13	8	37	15	25	48	0.17
HPM3/4B	3/4"	19	12	47	16	30	50	0.33
HPM1B	1"	25	19	58	20	37	58	0.57
HPM11/4B	1 1/4"	32	24	67	20	50	70	0.99
HPM11/2B	1 1/2"	38	29	70	21	55	77	1.26

** For continuous immersion in salt water, we advise against the use of brass fittings.



MARINE FITTINGS

Hose connector**

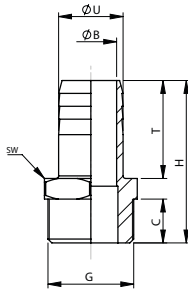

SLP

Type	Thread (G)* (inches)	ØU	ØB	H	C	SW	T	Weight (lbs)
SLP1/408	¼"	8	5	39	9	16	25	0.04
SLP1/416	¼"	16	9	44	9	16	30	0.06
SLP3/810	¾"	10	7	46	10	19	30	0.06
SLP3/815	¾"	15	11	46	10	19	30	0.06
SLP1/213	½"	13	9	48	12	22	30	0.08
SLP1/216	½"	16	12	48	12	22	30	0.08
SLP1/219	½"	19	15	50	12	22	32	0.11
SLP3/416	¾"	16	12	49	12	30	30	0.13
SLP3/419	¾"	19	14	51	12	30	32	0.17
SLP3/425	¾"	25	20	57	12	30	38	0.19
SLP125	1"	25	20	59	13	36	38	0.26
SLP132	1"	32	27	62	13	36	42	0.30
SLP11/432	1¼"	32	27	64	14	44	42	0.39
SLP11/438	1¼"	38	32	67	14	45	45	0.44
SLP11/238	1½"	38	32	67	16	42	43	0.51
SLP11/245	1½"	45	39	73	16	53	48	0.50
SLP251	2"	50	44	75	16	65	50	0.79
SLP21/260	2½"	60	53	82	18	79	52	1.25
SLP376	3"	76	69	96	20	93	64	1.85

*According to ISO 228/1-G..B

** For continuous immersion in salt water, we advise against the use of brass fittings.

Ball valves**

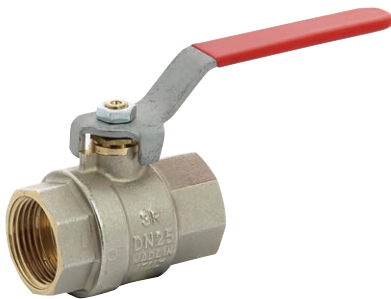

KRAAN

Nickel plated brass, suitable for water and diesel oil.

Type	Thread (G)* Female (inches)	Bore	Working Press (bar)	Working temp (° C)	Dimensions hxbxd	Weight (lbs)
KRAAN1/4	¼"	Full Bore	50	-20 - +170	105x50x24	0.24
KRAAN3/8	¾"	Full Bore	50	-20 - +170	105x50x24	0.30
KRAAN1/2	½"	Full Bore	50	-20 - +170	118x58x32	0.37
KRAAN3/4	¾"	Full Bore	30	-20 - +170	118x64x39	0.57
KRAAN1	1"	Full Bore	40	-20 - +170	154x86x48	0.88
KRAAN11/4	1¼"	Full Bore	40	-20 - +170	154x86x58	1.32
KRAAN11/2	1½"	Full Bore	32	-20 - +170	190x100x69	1.98
KRAAN2	2"	Full Bore	32	-20 - +170	200x120x84	3.19
KRAAN21/2	2½"	Full Bore	25	-20 - +170	270x145x102	6.61
KRAAN3	3"	Full Bore	16	-20 - +170	290x170x115	9.14

*According to ISO 228/1-G..

** For continuous immersion in salt water, we advise against the use of brass fittings.

Ball valves 3-way**

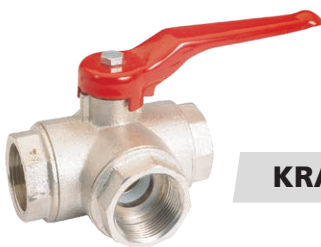

KRA

Nickel plated brass, suitable for water and diesel oil.

Type	Thread (G)* Female (inches)	Bore	Working Press (bar)	Working temp (° C)	Dimensions hxbxd	Weight (lbs)
KRA1/2L	½"	Full Bore	40	-10 - +100	80X160X70	1.43
KRA3/4L	¾"	Full Bore	40	-10 - +100	100X205X85	3.31
KRA1L	1"	Full Bore	40	-10 - +100	100X210X90	4.74
KRA11/4L	1¼"	Full Bore	40	-10 - +100	310X150X150	8.49
KRA11/2L	1½"	Full Bore	40	-10 - +100	310X150X120	13.00

*According to ISO 228/1-G..

** For continuous immersion in salt water, we advise against the use of brass fittings.





MARINE FITTINGS

Delrin (synthetic) fittings

Thru-hull - Chamfered



DOORN

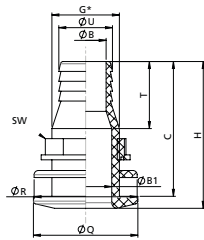

Type	Thread (G) (inches)	ØB	ØB1	H	C	ØQ	ØR	SW	T	ØU	Weight (lbs)
DOORN5/8	½"	10	16	76	71	42	41	24	29	16	0.04
DOORN3/4	¾"	12	18	81	75	50	49	32	32	19	0.06
DOORN1	1"	20	26	94	87	61	60	39	40	25	0.08
DOORN11/4	1¼"	24	32	98	91	68	67	48	44	32	0.15
DOORN11/2	1½"	29	37	104	96	74	73	54	47	38	0.17

Thru-hull - Chamfered



THRH

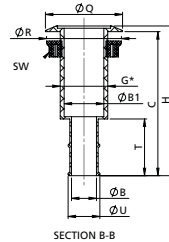
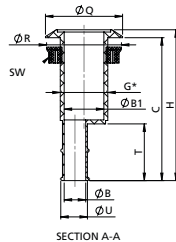

Type	Model A / B	Thread (G) (inches)	ØB	ØB1	H	C	ØQ	ØR	SW	T	ØU	Weight (lbs)
THRH16	B	¾"	8,5	20	73,5	70,5	50	39,5	34	29	16	0.04
THRH19	B	¾"	11,5	20	73,5	70,5	50	-	34	29	19	0.04
THRH25	A	1¼"	19	35	133	126	68	66	57	50	25	0.17
THRH28	B	1¼"	22	35	133	126	68	66	57	50	28	0.19
THRH32	A	1¼"	25	35	133	126	68	66	57	50	32	0.17
THRH38	A	1½"	32	38	127	121	68	66	56	46	38	0.24

Thru-hull with L-flange (for optimal drainage)



THRHL

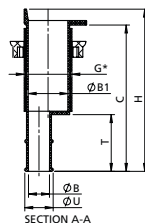
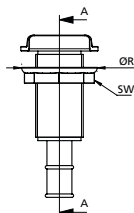
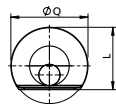

Type	Thread (G) (inches)	ØB	ØB1	H	C	ØQ	L	ØR	SW	T	ØU	Weight (lbs)
THRHL16L	¾"	8,5	20	85	72	50	37	-	34	29	16	0.04
THRHL19L	¾"	11	20	85	73	50	38	39,5	34	29	19	0.06
THRHL25L	1¼"	18,5	35	142	129	68	55	66	57	50	25	0.17
THRHL28L	1½"	22	35	142	129	68	55	66	56	50	28	0.24
THRHL32L	1¼"	25	35	142	129	68	55	66	57	50	32	0.17
THRHL38L	1½"	31,5	38	137	123	68	56	64	53	46	38	0.22



MARINE FITTINGS

Thru-hull - Chamfered

100° angled



THRH..BH

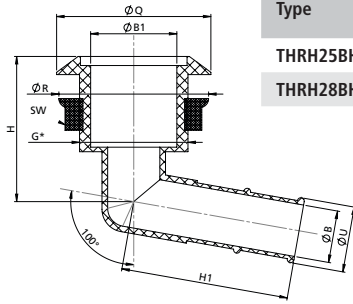

Type	Thread (G) (inches)	ØB	ØB1	H	H1	ØQ	ØR	SW	ØU	Weight (lbs)
THRH25BH	1½"	20	38	64	74	68	66	56	25	0,094
THRH28BH	1½"	20	38	64	74	68	66	56	28	0,094

Thru-hull - Flush

100° angled



THRH..BL

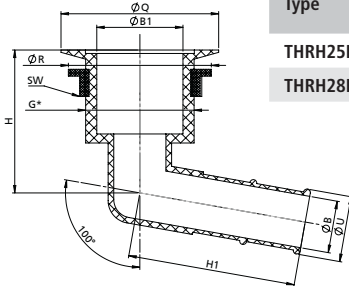

Type	Thread (G) (inches)	ØB	ØB1	H	H1	ØQ	ØR	SW	ØU	Weight (lbs)
THRH25BL	1½"	20	38	63	74	69,5	63	53	25	0,090
THRH28BL	1½"	20	38	63	74	69,5	63	53	28	0,090

Bulkhead connectors



BULKH

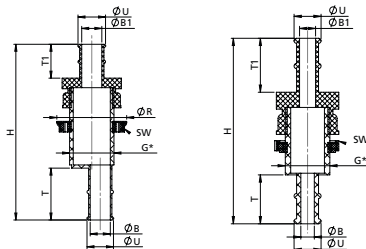

Type	Model A / B	Thread (G) (inches)	ØB	ØB1	H	ØQ	ØR	SW	T	T1	ØU	Weight (lbs)
BULKH16	B	¾"	8	9,5	110	50	-	34	29	32	16	0.08
BULKH19	A	¾"	11	13	113	50	40	34	29	32	19	0.08
BULKH25	A	1¼"	19	19	166	68	66	57	49	32	25	0.22
BULKH28	B	1¼"	22	22	175	68	66	57	49	32	28	0.24
BULKH32	A	1¼"	25	25	166	68	68	57	49	32	32	0.24
BULKH38	A	1½"	31	32	162	68	63	53	46	32	38	0.30

T-Piece



TPC

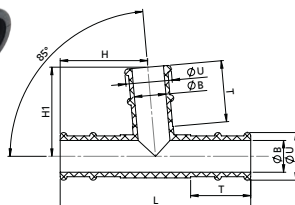

Plastic equal T-piece. Suitable for temperatures up to +181.4 °F (+83 °C).

Type	ØB	H	H1	L	T	ØU	Weight (lbs)
TPC16	10,5	39	40	84	26	16	0.03
TPC19	14	39	40	84	26	19	0.03
TPC25	17	54	52	99	32	25	0.06
TPC28	21	54	52	99	32	28	0.06





MARINE FITTINGS

End plug AISI 316 male

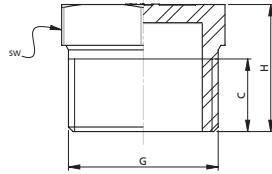

QS05020.

Type	Thread (G) (inches)	C	H	SW	Weight (lbs)
QS050203	3/8"	13	18,5	18	0.04
QS050204	1/2"	14,5	20,5	23	0.04
QS050205	3/4"	17	25	28	0.11
QS050206	1"	18	27	36	0.19
QS050207	1 1/4"	22	31	44	0.26
QS050208	1 1/2"	22	31	50	0.35
QS050209	2"	25	34	63	0.53

Bushing hex AISI 316 male - female

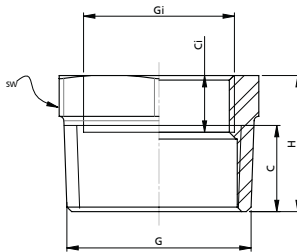

QS05060.

Type	Thread (G) (inches)	C	H	Thread (G1)* (inches)	C1	SW	Weight (lbs)
QS050603	3/8"	15	21	1/4"	8	19	0.04
QS050604	1/2"	16	23	3/8"	9	22	0.04
QS050605	3/4"	18	26	1/2"	10	28	0.11
QS050606	1"	18,5	27	3/4"	11	35	0.15
QS050607	1 1/4"	20,5	30	1"	13	44	0.24
QS050608	1 1/2"	22	31	1 1/4"	14	50	0.26
QS050609	2"	25	34	1 1/2"	13	63	0.44

* According to ISO 228/1-G..

T-Piece AISI 316 female

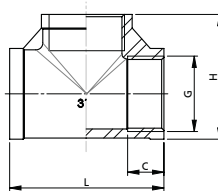

QS05030.

Type	Thread (G) (inches)	C	L	H	Weight (lbs)
QS050303	3/8"	10	42	31	0.11
QS050304	1/2"	11,5	50	40,7	0.22
QS050305	3/4"	12,5	61	46	0.33
QS050306	1"	16	70	54	0.53
QS050307	1 1/4"	15	80	65	0.63
QS050308	1 1/2"	18	95	69	1.08
QS050309	2"	18,5	108	81	1.47

Elbow 45° AISI 316 female

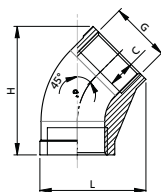

QS05070.

Type	Thread (G)* (inches)	C	L	H	Weight (lbs)
QS050703	3/8"	10	24		0.08
QS050704	1/2"	12	38	44	0.15
QS050705	3/4"	12	29	54	0.22
QS050706	1"	13	32		0.37
QS050707	1 1/4"	15	36	70	0.57
QS050708	1 1/2"	17	40		0.72

* According to ISO 228/1-G..



MARINE FITTINGS

Elbow 90° AISI 316 female

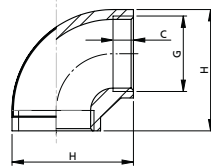

QS05040.

Type	Thread (G)* (inches)	C	H	Weight (lbs)
QS050403	3/8"	10	42	0.08
QS050404	1/2"	10	38	0.13
QS050405	3/4"	12	45	0.24
QS050406	1"	13	68	0.39
QS050407	1 1/4"	15	65	0.48
QS050408	1 1/2"	17	71	0.66
QS050409	2"	17,5	88	1.03

* According to ISO 228/1-G..

Elbow 90° AISI 316 male - female

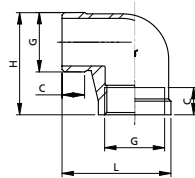

QS05010.

Type	Thread (G) (inches)	C	L	H	Weight (lbs)
QS050103	3/8"	12	32	22	0.08
QS050104	1/2"	13	48	38	0.11
QS050105	3/4"	13	38	32	0.19
QS050106	1"	18	73	56	0.41
QS050107	1 1/4"	20	84	61	0.61
QS050108	1 1/2"	15	60	52	0.68
QS050109	2"	24	89	108	1.47

Nipple AISI 316 male

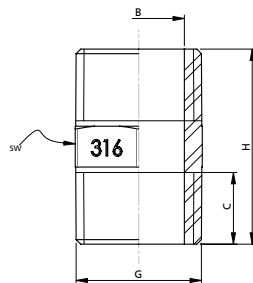

QS05050.

Type	Thread (G) (inches)	C	H	B	SW	Weight (lbs)
QS050503	3/8"	12	30	11	18	0.06
QS050504	1/2"	15	38	15,5	22	0.08
QS050505	3/4"	17	41	20	27	0.15
QS050506	1"	19	46	26	36	0.22
QS050507	1 1/4"	20	49	35	44	0.28
QS050508	1 1/2"	21	49	41	50	0.33
QS050509	2"	25	64	51	63	0.74

Socket AISI 316 female

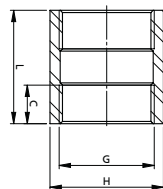

QS05080.

Type	Thread (G)* (inches)	C	L	H	Weight (lbs)
QS050803	3/8"	12	30	21	0.06
QS050804	1/2"	16	35	27	0.15
QS050805	3/4"	17	35	32	0.15
QS050806	1"	15	44	41	0.30
QS050807	1 1/4"	15	45	48	0.30
QS050808	1 1/2"	18	54	56	0.59
QS050809	2"	18	63	68	0.86

* According to ISO 228/1-G..





FITTINGS



AB16S



AB19S



AB19SL



AB16B



AB19B



AB25B



AB38B

Stainless steel (AISI 316) breather nipples

The breathing capacity fulfils the CE requirements. Provided with an easily cleaned stainless steel (AISI 316) gauze, which functions as a flame arrester.

Type	Shape	Hose Ø	Cut-out Ø	Max. wall thickness
AB16S	Straight	5/8	1 1/2	N/A
AB16B	Angled	5/8	1 1/2	1 3/16
AB19S	Straight	3/4	2 1/64	N/A
AB19SL	Straight	3/4	2 1/64	N/A
AB19B	Angled	3/4	2 1/64	1 7/32
AB25B	Angled	1	2 1/64	1 7/32
AB38B	Angled	1 1/2	2 7/8	1 21/32



ST04HS



ST04S



ST05HS



ST05S

Air vent nipples for tanks

Suitable for Ø 5/8" (16 mm) internal diameter hose. In stainless steel (AISI 316). Straight or 90° angled.

Type	Shape	Material	Hose Ø	Cut-out Ø	Wall thickness
ST04HS	Angled	AISI 316	5/8	25/32	0 - 25/64
ST04S	Straight	AISI 316	5/8	25/32	0 - 25/64
ST05HS	Angled	AISI 316	5/8	1 31/32	25/64 - 1 3/16
ST05S	Straight	AISI 316	5/8	1 31/32	25/64 - 1 3/16



FITTINGS



CAP..38S



CAP..51S

Stainless steel (AISI 316) deck entries

Stainless steel (AISI 316). With high-gloss polished watertight cover. Cover inscriptions:

- Water
- Unleaded gasoline
- Diesel fuel
- 'Pump-out' icon (WC)

These stainless steel (AISI 316) deck entries are also available with a winch handle socket (item codes ending with a 'W').



CAPWC38S



CAP..W

Type	Cap Ø (inches)	Type	Liquid	Hose Ø (inches)	Cut-out Ø (inches)	Length (inches)
CAPW38S	3 ⁷ / ₁₆	Slotted	Water	1 ¹ / ₂	2	2 ¹⁵ / ₁₆
CAPW38W	3 ⁷ / ₁₆	Winch	Water	1 ¹ / ₂	2	2 ¹⁵ / ₁₆
CAPG38S	3 ⁷ / ₁₆	Slotted	Unleaded Gasoline	1 ¹ / ₂	2	2 ¹⁵ / ₁₆
CAPG38W	3 ⁷ / ₁₆	Winch	Unleaded Gasoline	1 ¹ / ₂	2	2 ¹⁵ / ₁₆
CAPF38S	3 ⁷ / ₁₆	Slotted	Diesel fuel	1 ¹ / ₂	2	2 ¹⁵ / ₁₆
CAPF38W	3 ⁷ / ₁₆	Winch	Diesel fuel	1 ¹ / ₂	2	2 ¹⁵ / ₁₆
CAPWC38S*	3 ⁷ / ₁₆	Slotted	WC (pump out)	1 ¹ / ₂	2	4 ²³ / ₃₂
CAPWC38W*	3 ⁷ / ₁₆	Winch	WC (pump out)	1 ¹ / ₂	2	4 ²³ / ₃₂
CAPF51S	3 ²¹ / ₃₂	Slotted	Diesel fuel	2	2 ¹ / ₄	2 ¹⁵ / ₁₆
CAPF51W	3 ²¹ / ₃₂	Winch	Diesel fuel	2	2 ¹ / ₄	2 ¹⁵ / ₁₆

* Fullfills the requirements of ISO 8099:2001



KEY1

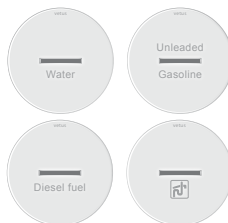

Deck entry key

Key for slotted deck entries. Also suitable for deck entries with an octagonal recess.



FCAPDF38



FCAPWC38

Chromium plated brass deck entries

Type	Cap Ø (inches)	Type	Liquid	Hose Ø (inches)	Cut-out Ø (inches)	Length (inches)
FCAPWATER	3 ¹¹ / ₃₂	Ring	Water	1 ¹ / ₂	2 ¹ / ₄	2 ¹⁵ / ₁₆
FCAPDF38	3 ¹¹ / ₃₂	Pop-out	Diesel fuel	1 ¹ / ₂	2 ¹ / ₄	2 ¹⁵ / ₁₆
FCAPDF50	3 ¹¹ / ₃₂	Pop-out	Diesel fuel	1 ³¹ / ₃₂	2 ¹ / ₄	2 ¹⁵ / ₁₆
CAPWC38*	3 ¹⁵ / ₃₂	Pop-out	Waste (pump out)	1 ¹ / ₂	1 ³¹ / ₃₂	4 ¹⁷ / ₃₂

* Fullfills the requirements of ISO 8099:2001



CAPWC38



FCAPDF50





FITTINGS

Stainless steel hose clamps

For hose diameters between:
5/16" and 6 11/16" (8 mm and 170 mm).



W4 materials:

- Screw • AISI 304
- Band + housing • AISI 304

HCS

Type	Description	Band width	Max. torque (Nm)	Max. pressure (Bar)
HCS08	D 5/16 - 5/8	23/64	3	45
HCS12	D 15/32 - 5/8	23/64	3	45
HCS16	D 5/8 - 1 1/16	15/32	4.6	45
HCS20	D 23/32 - 1 1/8	15/32	5.6	45
HCS25	D 1 - 1 3/16	15/32	5.6	40
HCS32	D 1 17/64 - 1 31/32	15/32	6.5	35
HCS40	D 1 37/64 - 2 23/64	15/32	6.5	30

HCHD

Type	Description	Band width	Max. torque (Nm)	Max. pressure (Bar)
HCS50	D 1 31/32 - 2 1/4	15/32	7	25
HCS60	D 2 23/64 - 3 3/32	15/32	7	20
HCS75	D 2 1/4 - 3 35/64	15/32	7	17
HCS90	D 3 3/16 - 4 7/16	15/32	7	12
HCS110	D 3 3/16 - 5 1/8	15/32	7	8
HCS130	D 5 1/8 - 5 29/32	15/32	7	6
HCS150	D 5 29/32 - 6 11/16	15/32	7	4

HCHDS

Heavy duty hose clamps

For hose diameters between: 1 11/32" and 13" (34 mm and 330 mm).

Type	Description	Band width	Max. torque (Nm)	Max. pressure (Bar)
HCHD034	D 1 11/32 - 1 29/64	25/32	13	40
HCHD037	D 1 29/64 - 1 37/64	25/32	13	40
HCHD040	D 1 37/64 - 1 11/16	25/32	13	40
HCHD043	D 1 11/16 - 1 27/32	25/32	16	36
HCHD047	D 1 27/32 - 2 1/64	25/32	16	36
HCHD051	D 2 1/64 - 2 11/64	25/32	16	36
HCHD055	D 2 11/64 - 2 21/64	25/32	16	36
HCHD059	D 2 21/64 - 2 31/64	25/32	16	36
HCHD063	D 2 31/64 - 2 43/64	25/32	16	36
HCHD068	D 2 43/64 - 2 7/8	1	30	28
HCHD073	D 2 7/8 - 3 1/64	1	30	28
HCHD079	D 3 1/64 - 3 11/32	1	30	28
HCHD085	D 3 11/32 - 3 37/64	1	30	20
HCHD091	D 3 37/64 - 3 13/16	1	30	20

W2 materials:

- Band + bridge Bolt • AISI 430
- QST 36-3 Mild steel silver white zinc plated

Type	Description	Band width	Max. torque (Nm)	Max. pressure (Bar)
HCHD097	D 3 13/16 - 4 3/32	1	30	20
HCHD104	D 4 3/32 - 4 13/32	1	30	12
HCHD112	D 4 13/32 - 4 49/64	1	30	12
HCHD121	D 4 49/64 - 5 1/8	1	30	12
HCHD130	D 5 1/8 - 5 33/64	1 7/64	45	9
HCHD140	D 5 33/64 - 5 29/32	1 7/64	45	9
HCHD150	D 5 29/32 - 6 1/8	1 7/64	45	9
HCHD162	D 6 1/8 - 6 27/32	1 7/64	45	6
HCHD174	D 6 27/32 - 7 23/64	1 7/64	45	6
HCHD187	D 7 23/64 - 7 7/8	1 7/64	45	6
HCHD200	D 7 7/8 - 8 5/64	1 7/64	45	3
HCHD213	D 8 5/64 - 8 57/64	1 7/64	45	3
HCHD260	D 10 7/8 - 10 15/16	1 3/16	NA	NA
HCHD300	D 12 15/32 - 13	1 3/16	NA	NA

Stainless steel heavy duty hose clamps

For hose diameters between: 1 11/32" and 13" (34 mm and 330 mm).

Type	Description	Band width	Max. torque (Nm)	Max. pressure (Bar)
HCHDS034	D 1 11/32 - 1 29/64	25/32	12	35
HCHDS037	D 1 29/64 - 1 37/64	25/32	12	35
HCHDS040	D 1 37/64 - 1 11/16	25/32	12	35
HCHDS043	D 1 11/16 - 1 27/32	25/32	12	35
HCHDS047	D 1 27/32 - 2 1/64	25/32	16	30
HCHDS051	D 2 1/64 - 2 11/64	25/32	16	30
HCHDS055	D 2 11/64 - 2 21/64	25/32	16	30
HCHDS059	D 2 21/64 - 2 31/64	25/32	16	30
HCHDS063	D 2 31/64 - 2 43/64	25/32	16	30
HCHDS068	D 2 43/64 - 2 7/8	1	30	20
HCHDS073	D 2 7/8 - 3 1/64	1	30	20
HCHDS079	D 3 1/64 - 3 11/32	1	30	20
HCHDS085	D 3 11/32 - 3 37/64	1	30	15
HCHDS091	D 3 37/64 - 3 13/16	1	30	15

W4 materials:

- Band + bridge Bolt • AISI 304
- AISI 302

Type	Description	Band width	Max. torque (Nm)	Max. pressure (Bar)
HCHDS097	D 3 13/16 - 4 3/32	1	30	15
HCHDS104	D 4 3/32 - 4 13/32	1	30	10
HCHDS112	D 4 13/32 - 4 49/64	1	30	10
HCHDS121	D 4 49/64 - 5 1/8	1	30	10
HCHDS130	D 5 1/8 - 5 1/2	1 3/32	45	6
HCHDS140	D 5 1/2 - 5 29/32	1 3/32	45	6
HCHDS150	D 5 29/32 - 6 3/8	1 3/32	45	6
HCHDS162	D 6 3/8 - 6 27/32	1 3/32	45	3
HCHDS174	D 6 27/32 - 7 3/8	1 3/32	45	3
HCHDS187	D 7 3/8 - 7 7/8	1 3/32	45	3
HCHDS200	D 7 7/8 - 8 3/8	1 3/32	45	3
HCHDS213	D 8 3/8 - 8 29/32	1 3/32	45	3
HCHDS260	D 10 7/8 - 10 15/16	1 3/16	NA	NA
HCHDS300	D 12 15/32 - 13	1 3/16	NA	NA



PUMPS



BLP..

Bilge pumps

Submersible bilge pumps (IP67). Detachable strainer acts as screw-down base. Durable snap connection for easy cleaning. Double seals for long lifetime. Internal components are made from stainless steel (AISI 316). Comes with 47 1/4 ft. (1.2 metre) cable. For all suitable hoses see page 404.

Type	Voltage (V)	Current A @ 13,6 V	Capacity gal/min	Max. head (ft)	Dimensions Ø x H	Hose connection Ø	Advised hose type
BLP12500	12	3	8.8	13	3 ³⁵ / ₆₄ X 4 ²³ / ₃₂	3/4	DWBOSE19B
BLP121000	12	3	11	13	3 ³⁵ / ₆₄ X 4 ²³ / ₃₂	1/8	DWBOSE28B
BLP122000	12	6	24	13	4 ²² / ₃₂ X 5 ²⁹ / ₃₂	1/8	DWBOSE28B
BLP123000	12	9	35	16	5 1/8 X 7 ³ / ₃₂	1 ¹⁷ / ₆₄	DWBOSE32B

Type	Voltage (V)	Current A @ 27,1 V	Capacity gal/min	Max. head (ft)	Dimensions Ø x H	Hose connection Ø	Advised hose type
BLP24500	24	1,5	8.8	13	3 ³⁵ / ₆₄ X 4 ²³ / ₃₂	3/4	DWBOSE19B
BLP242000	24	3	24.4	13	4 ²² / ₃₂ X 5 ²⁹ / ₃₂	1/8	DWBOSE28B
BLP243000	24	4,5	32	16	5 1/8 X 7 ³ / ₃₂	1 ¹⁷ / ₆₄	DWBOSE32B



BLSWITCH

Level switch

This switch activates the pump when the bilge water level reaches 1 3/32" (50 mm).

- Made from high quality synthetic material
- Suitable for 12 and 24 Volt
- Suitable for fresh and salt water
- Comes with 39 3/8 ft (1 metre) cable

Type	Voltage (V)	Max. current (A)	Total width	Total length	Cable length (ft)
BLSWITCH	12 / 24	15	2 3/4	4 39/64	39 3/8



BLPM020

Manual membrane pump

A high quality membrane pump suitable for pumping/ transferring bilge water, seawater or diesel.

- Synthetic housing, metallic parts of stainless steel (AISI 316)
- Easy to remove clamping ring for maintenance and or head rotation
- Horizontal or vertical mounting
- Self-priming

Suitable for boats up to 39" (12 m) (ISO 15083)
For all suitable hoses see page 404.

Type	Suction lift (m)	Discharge head (m)	Capacity L/stroke	Hose connection Ø	Advised hose type
BLPM020	10	13	1/64	1 ¹⁷ / ₆₄	DWBOSE32B



BLPS..

Stirrup type pumps

Sturdy single action plunger pump suitable for fresh water, seawater or other fluids normally present in the bilge.

- Material: durable plastic (PP)
- Temperature resistant to max. 140°F (60° Celsius)
- Ergonomically shaped handle
- Self priming
- Hose length: 38 37/64" (980 mm)

Type	Hose connection Ø	Stroke length	Capacity L/stroke
BLPS05	1 ¹⁷ / ₆₄	12 ¹⁹ / ₃₂	1/64
BLPS08	1 ¹⁷ / ₆₄	18 ⁷ / ₆₄	1/32





OUTBOARD

Cable steering

The cable length refers to total length of the inner cable. The outer jacket of the cable is about 75 cm (30") shorter. When selecting the right cable, always round up to the next size.

Cable length:

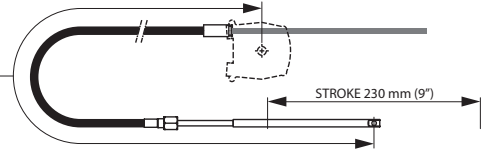

LCSKIT..

Light series cable steering kit

Cable steering kit including: Helm, straight bezel, cable and spent core tube. The helm is equipped as standard with a friction brake. Fitted with a $\varnothing \frac{3}{4}$ " (19 mm) shaft, tapered 1:12.

Available with cable length: 7 to 16 ft (213 to 488 cm), in steps of 1 ft.

- Wheel turns: $\frac{7}{64}$ " (2,6 mm)
- Max. wheel \varnothing : 16" (406 mm)
- Min. bend radius $11\frac{57}{64}$ " (302 mm)

For craft up to 16ft (5 m).

Type	Max. engine output	Cable length
LCSKIT7	55 HP (40 kw)	7 ft (213.5 cm)
LCSKIT8	55 HP (40 kw)	8 ft (244 cm)
LCSKIT9	55 HP (40 kw)	9 ft (274.5 cm)
LCSKIT10	55 HP (40 kw)	10 ft (305 cm)
LCSKIT11	55 HP (40 kw)	11 ft (335.5 cm)

Type	Max. engine output	Cable length
LCSKIT12	55 HP (40 kw)	12 ft (366 cm)
LCSKIT13	55 HP (40 kw)	13 ft (396.5 cm)
LCSKIT14	55 HP (40 kw)	14 ft (427 cm)
LCSKIT15	55 HP (40 kw)	15 ft (457.5 cm)
LCSKIT16	55 HP (40 kw)	16 ft (488 cm)



HZFKIT..

Zero feedback cable steering kit

Zero torque high performance cable steering kit including: Zero feedback helm, straight bezel, high performance cable and spent core tube. Smooth and durable operation due to planetary gear design. Unique design eliminates any torque coming from the steering cable, creating an effortless ride. A 20° Bezel kit can be ordered separately if required.

Fitted with a $\varnothing \frac{3}{4}$ " (19 mm) shaft, tapered 1:12. A.B.Y.C., N.M.M.A., I.M.C.I. and CE approved.

Available with cable length: 8 to 20 ft (244 to 610 cm), in steps of 1 ft.

- Wheel turns: $\frac{5}{32}$ " (3,8 mm)
- Max. wheel \varnothing : 16" (406 mm)
- Min. bend radius $7\frac{7}{8}$ " (200 mm)

For craft up to 22 ft (7 m).

Type	Max. engine output	Cable length
HZFKIT8	125 HP (90 kw)	8 ft (244 cm)
HZFKIT9	125 HP (90 kw)	9 ft (274.5 cm)
HZFKIT10	125 HP (90 kw)	10 ft (305 cm)
HZFKIT11	125 HP (90 kw)	11 ft (335.5 cm)
HZFKIT12	125 HP (90 kw)	12 ft (366 cm)
HZFKIT13	125 HP (90 kw)	13 ft (396.5 cm)
HZFKIT14	125 HP (90 kw)	14 ft (427 cm)

Type	Max. engine output	Cable length
HZFKIT15	125 HP (90 kw)	15 ft (457.5 cm)
HZFKIT16	125 HP (90 kw)	16 ft (488 cm)
HZFKIT17	125 HP (90 kw)	17 ft (518.5 cm)
HZFKIT18	125 HP (90 kw)	18 ft (549 cm)
HZFKIT19	125 HP (90 kw)	19 ft (579.5 cm)
HZFKIT20	125 HP (90 kw)	20 ft (610 cm)



OUTBOARD

Cable steering options



HB20

Bezel kit

To tilt the helm at a 20° angle for optimum steering position. 20° Bezel kit for zero feedback cable steering helm. Weight 0,7 lbs. (0,3 kg.)

Type	Description
HB20	High performance series 20° bezel kit



SQBALL

Quick release balljoint

Quick release balljoint for steering cables. For L and H series. Weight 0,7 lbs. (0,3 kg.)

Type	Description
SQBALL	H and L series, steering cable quick release balljoint

Cable steering mounting sets

To complete the steering system to your requirements, please select one of the mounting sets below.



SLINK

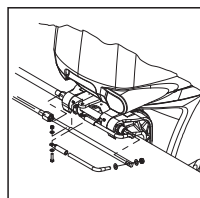

Universal link arm

When outboard motor acts as cable mount. For L and H series.

Type	Description
SLINK	Steering cable universal link arm

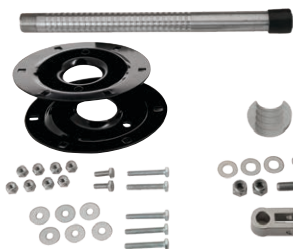

SSPLASH

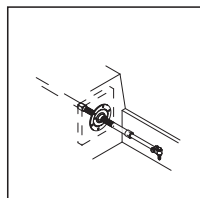

Splashwell mount

Splashwell cable support mount for L and H series.

Type	Flange Ø	Weight (lbs)
SSPLASH	4 ³⁹ / ₆₄	1.65

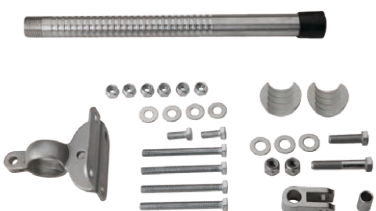

STRANS

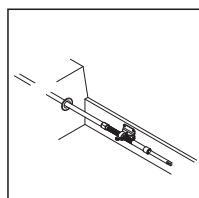

Transom mount

Transom support mount (short) for L and H series.

Type	Length* (inches)	Angle	Weight (lbs)
STRANS	2 ¹ / ₆₄	90°	1.5

*Cable core to transom





OUTBOARD



STRANL

Transom mount

Transom support mount (long) for L and H series.

Type	Length* (inches)	Angle	Weight (lbs)
STRANL	4 ¹ / ₆₄	67°	1.8

*Cable core to transom

Steering cable only

Available for light series and high performance series.
Length between 5 and 20 feet (153 to 610 cm), in steps of 1 ft.
Max. bend radius: 7⁷/₈" (200 mm).

For light series: LCAB (max. 55 HP / 40 kw)
For zero feedback series: HCAB (max. 125 HP / 90 kw)



LCAB..

Type	Cable length	Type	Cable length
LCAB5	5 ft (152.5 cm)	LCAB13	13 ft (396.5 cm)
LCAB6	6 ft (183 cm)	LCAB14	14 ft (427 cm)
LCAB7	7 ft (213.5 cm)	LCAB15	15 ft (457.5 cm)
LCAB8	8 ft (244 cm)	LCAB16	16 ft (488 cm)
LCAB9	9 ft (274.5 cm)	LCAB17	17 ft (518.5 cm)
LCAB10	10 ft (305 cm)	LCAB18	18 ft (549 cm)
LCAB11	11 ft (335.5 cm)	LCAB19	19 ft (579.5 cm)
LCAB12	12 ft (366 cm)	LCAB20	20 ft (610 cm)



HCAB..

Type	Cable length	Type	Cable length
HCAB5	5 ft (152.5 cm)	HCAB13	13 ft (396.5 cm)
HCAB6	6 ft (183 cm)	HCAB14	14 ft (427 cm)
HCAB7	7 ft (213.5 cm)	HCAB15	15 ft (457.5 cm)
HCAB8	8 ft (244 cm)	HCAB16	16 ft (488 cm)
HCAB9	9 ft (274.5 cm)	HCAB17	17 ft (518.5 cm)
HCAB10	10 ft (305 cm)	HCAB18	18 ft (549 cm)
HCAB11	11 ft (335.5 cm)	HCAB19	19 ft (579.5 cm)
HCAB12	12 ft (366 cm)	HCAB20	20 ft (610 cm)



INFLATABLE BOATS

VB Series

The VB series of inflatable boats are designed for optimum durability, usability and performance. The high level of attention to detail during manufacturing results in rugged boats with an absolutely top class finish. By selecting the best materials and accessories these boats have just that little bit extra.

Based on many years of boating experience, we've equipped the boats with many practical features. Take for example the shape of the tube ends. Together with the triangular trim flaps at the transom, the angled design of the tubes provides extra planing surface to help get the boat up onto the plane. When going fast, there is an ergonomically placed grab handle just at the right place inside the boat. Prefer to row around the harbour? Adjust the seat on the continuous bench support to find the optimum rowing position.

Packed in a sleek overall design, V-Quipment boats offer great benefits at a very attractive price! Get on board and experience all the benefits whilst enjoying every minute on the water!

Choosing the right boat

The VB series of inflatable boats is available in five boat lengths of 6ft 6in, 7ft 6in, 8ft 10in, 9ft 10in or 10ft 9in (200, 230, 270, 300 or 330 cm) overall. The preferred length depends on your personal application. Do you need a lot of space, or does the boat need to fit the davits? How many people should be able to enjoy the boat at once? See the technical specifications on the next page.

In addition, there are two types of deck available. VB Traveller boats have an inflatable deck, whilst VB Explorer boats have a folding aluminium deck. Both versions are rigid when installed and feature a deep V hull for greater stability at both low and high speeds. Each has its individual advantages. Please see a detailed overview on the next page.

To provide the optimum freedom in usage, all models are equipped with multiple carrying handles and D rings, for towing, lifting, and anchoring of the boat.

The fun starts with selecting the right boat. Imagine what adventures you are going to have: Rowing ashore to get to know new places, exploring the coastline, sunbathing away from the crowd, snorkeling, or even waterskiing?



1.

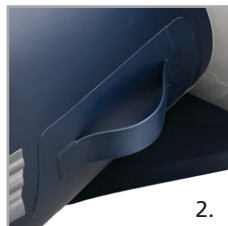

2.



3.



4.



5.



6.



7.

1. The angled stern tubes, and the trim flaps at the transom provide a greater planing surface. In addition, the rounded stern tubes with continuous rubbing strake are less prone to damage
2. Convenient grab handles at the transom
3. Additional grab handles ideally placed for the driver when motoring
4. Oar storage inside the boat and quick storage clamp on the top of the tubes
5. The bench can be repositioned and optionally a second bench can be installed
6. Deep V keel with rubbing strake protector. The side tubes are protected with an additional layer of PVC fabric at the bottom
7. Multiple D rings allow for towing and hoisting the boat





INFLATABLE BOATS

Features and benefits

- High quality, durable PVC fabric with polyester reinforcement, 1100 Decitex (1000 gram), 0.9 mm
- Three separate tube compartments are equipped with high quality valves
- A pressure relief valve is included to prevent over-inflation
- Double layer of PVC fabric at the bottom of the tubes for protection against wear
- Rubbing strake protector covering the tubes and the keel
- The boats are lightweight and easy to carry
- Four sturdy carry handles with integrated cleats on the sides
- Convenient grab handles at the transom
- Additional grab handles ideally placed for the driver when motoring
- Stern tubes are shaped to provide a greater planing surface.
- Hull extensions at the transom also enhance planing
- Rounded stern tubes with continuous rubbing strake are less prone to damage
- Choose between a lightweight inflatable deck and or a hard wearing aluminium deck
- Integrated strap to secure the fuel tank
- Inflatable deep V keel for greater stability under power and when rowing
- Reinforced transom connection to the tubes for extra rigidity
- One-way drain plug with closure, without loose parts
- Oar storage inside the boat and quick storage clamp on the top of the tubes
- Aluminium oars can be disassembled for easy transportation and storage
- A lightweight aluminium bench seat is standard. Optionally, a second bench can be installed
- The adjustable bench support allows any seat layout to fit your needs the best



Anchor D ring with integrated carrying handle at the bow



Double D-rings at the bow for towing



Double lifting rings at the bow and stern

VB Traveller

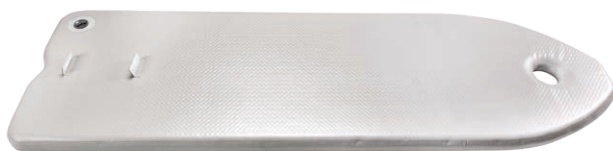

- Inflatable board deck
- Lightweight and compact for easy storage and transportation
- Robust, flat deck with anti-slip surface

VB Traveller boats are ideal for short trips, for example as a yacht tender. The compact dimensions when deflated make this model very convenient when transportation or storage is an issue.

These boats are equipped with an inflatable deck. The decks are manufactured using drop-stitch technology. This construction is also used in inflatable surf boards and handles the extremely high pressure needed for performance. When under pressure, the air deck offers a robust flat surface to stand on and creates a performance increasing deep V hull. A strap to secure the fuel tank is incorporated in the deck as standard.

VB Explorer



- Folding aluminium deck
- High stability and performance
- Sturdy flat deck with anti-slip surface

VB Explorer boats offer the best performance for longer trips or when heavily loaded. The sturdy aluminium deck creates a rigid hull shape. In addition, the extruded aluminium panels provide a stable deck to carry people and goods. This deck also facilitates a deep V hull and incorporates a strap for the fuel tank.



INFLATABLE BOATS

Type	VB200T	VB230T	VB270T	VB300T	VB330T
Type	Traveller 200	Traveller 230	Traveller 270	Traveller 300	Traveller 330
Deck type	Inflatable drop-stitch board deck				
Length overall	78 ⁴⁷ / ₆₄ " - 200 cm	90 ³⁵ / ₆₄ " - 230 cm	106 ¹⁹ / ₆₄ " - 270 cm	118 ⁷ / ₆₄ " - 300 cm	129 ⁵⁹ / ₆₄ " - 330 cm
Beam width overall	54 ²³ / ₃₂ " - 139 cm	51 ³ / ₁₆ " - 130 cm	60 ⁵ / ₈ " - 154 cm	60 ⁵ / ₈ " - 154 cm	60 ⁵ / ₈ " - 154 cm
Tube diameter	16 ⁹ / ₆₄ " - 41 cm	13 ²⁵ / ₃₂ " - 35 cm	16 ¹⁷ / ₃₂ " - 42 cm	16 ¹⁷ / ₃₂ " - 42 cm	16 ¹⁷ / ₃₂ " - 42 cm
Packed size	41 ¹¹ / ₃₂ x 27 ⁹ / ₁₆ x 12 ¹⁹ / ₃₂ 105 x 70 x 32 cm	41 ¹¹ / ₃₂ x 27 ⁹ / ₁₆ x 12 ¹⁹ / ₃₂ 105 x 70 x 35 cm	45 ⁹ / ₃₂ x 27 ⁹ / ₁₆ x 14 ⁶¹ / ₆₄ 115 x 70 x 38 cm	45 ⁹ / ₃₂ x 27 ⁹ / ₁₆ x 12 ¹⁹ / ₃₂ 115 x 70 x 38 cm	45 ⁹ / ₃₂ x 27 ⁹ / ₁₆ x 12 ¹⁹ / ₃₂ 115 x 70 x 38 cm
Payload	551 lbs	794 lbs	1069 lbs	1102 lbs	1257 lbs
Max. capacity persons	2	2	3	3+1 (child)	4
Total boat weight	57 lbs	75 lbs	97 lbs	105 lbs	112 lbs
Shipping weight	72.75 lbs	83.77 lbs	97 lbs	105.82 lbs	112.43 lbs
Max. horse power	3,7 hp	5 hp	10 hp	10 hp	15 hp
Design category	D	D	C	C	C
Standard supply	Carry / storage bag, foot pump with high pressure chamber, repair kit with spare pump connector, two aluminium oars, one aluminium bench				



Type	VB230E	VB270E	VB300E	VB330E
Type	Explorer 230	Explorer 270	Explorer 300	Explorer 330
Deck type	Foldable aluminium deck			
Length overall	90 ³⁵ / ₆₄ " - 230 cm	106 ¹⁹ / ₆₄ " - 270 cm	118 ⁷ / ₆₄ " - 300 cm	129 ⁵⁹ / ₆₄ " - 330 cm
Beam width overall	51 ³ / ₁₆ " - 130 cm	60 ⁵ / ₈ " - 154 cm	60 ⁵ / ₈ " - 154 cm	60 ⁵ / ₈ " - 154 cm
Tube diameter	13 ²⁵ / ₃₂ " - 35 cm	16 ¹⁷ / ₃₂ " - 42 cm	16 ¹⁷ / ₃₂ " - 42 cm	16 ¹⁷ / ₃₂ " - 42 cm
Packed size	41 ¹¹ / ₃₂ x 27 ⁹ / ₁₆ x 12 ¹⁹ / ₃₂ 105 x 70 x 35 cm	45 ⁹ / ₃₂ x 27 ⁹ / ₁₆ x 12 ¹⁹ / ₃₂ 115 x 70 x 38 cm	45 ⁹ / ₃₂ x 27 ⁹ / ₁₆ x 12 ¹⁹ / ₃₂ 115 x 70 x 38 cm	45 ⁹ / ₃₂ x 27 ⁹ / ₁₆ x 12 ¹⁹ / ₃₂ 115 x 70 x 38 cm
Payload	793.5 lbs	1069 lbs	1102 lbs	1256.5 lbs
Max. capacity persons	2	3	3+1 (child)	4
Total boat weight	97 lbs	114.5 lbs	130 lbs	143.3 lbs
Shipping weight	97 lbs	114.64 lbs	130.07 lbs	143.30 lbs
Max. horse power	5 hp	10 hp	10 hp	15 hp
Design category	D	C	C	C
Standard supply	Carry / storage bag, foot pump, repair kit with spare pump connector, two aluminium oars, one aluminium bench			

Accessories

Type	Description
VBEN74	Extra aluminium bench 29 ⁹ / ₆₄ " - 74 cm (for type 200 and 230)
VBEN85	Extra aluminium bench 33 ¹⁵ / ₃₂ " - 85 cm (for type 270 to 330)
VBENBG	Seat bag, black. With cushion, light gray
VBCOV20	Boat cover, light grey, 78 ⁴⁷ / ₆₄ " - 200 cm
VBCOV23	Boat cover, light gray, 90 ³⁵ / ₆₄ " - 230 cm
VBCOV27	Boat cover, light gray, 106 ¹⁹ / ₆₄ " - 270 cm
VBCOV30	Boat cover, light gray, 118 ⁷ / ₆₄ " - 300 cm
VBCOV33	Boat cover, light gray, 129 ⁵⁹ / ₆₄ " - 330 cm

Service parts

Type	Description
VBREPAIR	Repair kit complete
VBPUMP01	Foot pump max 0,25 bar pressure gauge
VBPUMP02	Foot pump max 0,25 bar / 1 bar
VBPCON	Air valve connector
VBDRAIN	Drain plug set
VBHAND	Hand grab with cleat
VBVENT	Air valve
VBCBAG	Carry bag
VBOAR	Oar 59 ²⁷ / ₃₂ " - 152 cm (set 2 pcs) for model 230, 270, 300 and 330
VBOAR20	Oar 51 ³¹ / ₃₂ " - 132 cm (set 2 pcs) for model 200
VBOARL	Oarlock, complete
VBOARN	Oarlock, nut only

See website for all service parts

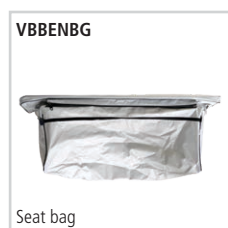



RIGID INFLATABLE BOATS

VETUS RIB Frontier

The Frontier series takes you places you have never been before. Durable, sturdy and with proper ergonomics: this is the boat for the adventurer! Go fast with the V-shaped full aluminium hull, experience maximum grip from the non-slip deck covering and (for the VR270/300/330 only) benefit from a double floor and a front locker to store your luggage.

The Frontier series is here to stay. Constructed from 0,9 mm thick 1100 digitex heavy duty cloth and finished in a smart grey-and-blue colour combination, pioneering on a water near you for years to come.



Specifications

- Aluminium deep V-shaped hull
- Non-slip deck covering
- Multiple grab handles for easy carrying
- Quick oar storage clamps on the tubes
- Multiple D-rings for towing and hoisting the boat

Type	VR240B	VR270B	VR270	VR300	VR330
Length overall (L)	7ft 10.5in (240 cm)	8ft 10 in (270 cm)	8ft 10 in (270 cm)	9ft 10in (300 cm)	10ft 9 in (330 cm)
Inside width (W)	2ft 7.5in (80 cm)	2ft 7.5in (80 cm)	2ft 7.5in (80 cm)	2ft 7.5in (80 cm)	2ft 7.5in (80 cm)
Beam width overall (X)	5ft 5.5in (164 cm)	5ft 5.5in (164 cm)	5ft 5.5in (164 cm)	5ft 5.5in (164 cm)	5ft 5.5in (164 cm)
Tube diameter (Q)	1ft 4.5in (42 cm)	1ft 4.5in (42 cm)	1ft 4.5in (42 cm)	1ft 4.5in (42 cm)	1ft 4.5in (42 cm)
Max. total load	300 kg (770 lbs)	400 kg (880 lbs)	400 kg (880 lbs)	450 kg (990 lbs)	500 kg (1100 lbs)
Packed size	5ft 7in x 4ft 0.75 in x 1ft 11.25in 170 x 124 x 59 cm	6ft 6.75in x 4ft 0.75in x 1ft 11.25 in 200 x 124 x 59 cm	6ft 6.75in x 4ft 0.75in x 1ft 11.25 in 200 x 124 x 59 cm	7ft 10.5in x 4ft 0.75in x 1ft 11.25 in 240 x 124 x 59 cm	8ft 10.25in x 4ft 0.75in x 1ft 11.25 in 270 x 124 x 59 cm
Max. capacity persons	2	3	3	4	4+1 (child)
Flat deck	No	No	Yes	Yes	Yes
Front locker	No	No	Yes	Yes	Yes
Total boat weight	92.59 lbs	103.61 lbs	130.07 lbs	147.71 lbs	165.34 lbs
Max. outboard power	5 hp	10 hp	10 hp	15 hp	20 hp

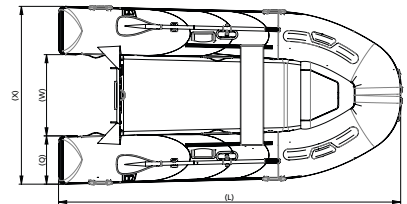

SUP BOARD

Stand-up paddle board

Stand up paddle boarding is an offshoot of surfing that originated in Hawaii. The body is made of high quality, durable, double layer pvc fabric. The double layer prevents the stand up paddle board from bending. EVA foam prevents the user from slipping.

Specifications

- Two fixed and one removable fin
- One carry handle
- 4 Point cargo tie-down system
- High quality valve
- Supplied with one all terrain backpack
- Supplied with pump
- Supplied with repair kit
- Supplied with one paddle

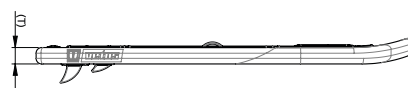
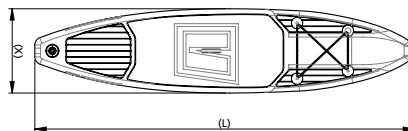

Type	VSUP11
Length overall (L)	10ft 12in (335 cm)
Width overall (X)	2ft 7.5in (80 cm)
Thickness (T)	5.9in (15 cm)
Packed size	32.28 in x 17.71 in x 11.81in (82 x 45 x 30 cm)
Max. capacity persons	1
Payload	396.83lbs (180 kg)
Netto weight	30.86lbs (14 kg)
Standard supply	Pump, repair kit, paddle and all terrain backpack

VSUP11





MATERIALS

Non-slip deck covering

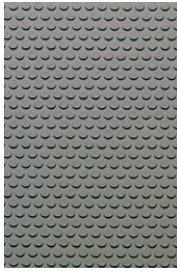

ANTI..HAP

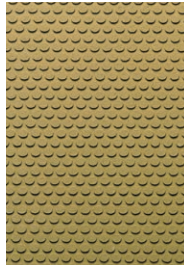

ANTI..SAF

Deck covering, made of rubber, cork and plastic. This material has incredibly high non-slip properties under all circumstances. It is highly resistant against sunlight, seawater and oil. Suitable for all types of decks (steel, glassfibre, wood, aluminium and concrete).

Available colours:

- Happy Elephant (grey)
- Safari (light brown)

Type	Dimension	Thickness
ANTI12HAP	35 1/2" x 47 1/4" - 900 x 1200 mm	1/8 - 3 mm
ANTI24HAP	35 1/2" x 94 1/2" - 900 x 2400 mm	1/8 - 3 mm
ANTI12SAF	35 1/2" x 47 1/4" - 900 x 1200 mm	1/8 - 3 mm
ANTI24SAF	35 1/2" x 94 1/2" - 900 x 2400 mm	1/8 - 3 mm

VETUS Fix



BOATFIX1

This glue has been specially developed to bond VETUS non-slip deck covering. However, it is also very suitable for bonding P.V.C.- and polyester foil to leather and wood. Excellent adhesion is obtained as well on laminated plastics such as Formica, hard P.V.C. and ABS.

A can of (0.26 gal) 1 litre VETUS FIX is sufficient to glue 25 to 32 sq. ft. (2 to 3 m²).

Type	Description
BOATFIX1	Boatfix adhesive 1 ltr - 0.26 gallons

INTERIOR MATERIALS

Poly-wood



SH..WSH

SH..WH

SH..WXSH

This material is ideal for the fabrication of all sorts of components on board. It is completely resistant against sunlight and water and is tough and durable. It is easy to work with using common woodworking machinery and tools. The product is made of solid plastic and is not laminated. Poly-wood cannot rot, splinter, crack open or show discolouration and is therefore particularly suitable for outdoor use in all weather conditions.

Available colour:

- White

Type	Dimension	Thickness
SH06WXSH	47 41/64" x 23 5/8" (1210 x 600 mm)	15/64" - 6 mm
SH12WXSH	47 41/64" x 23 5/8" (1210 x 600 mm)	15/32" - 12 mm
SH18WXSH	47 41/64" x 23 5/8" (1210 x 600 mm)	45/64" - 18 mm
SH06WSH	48 1/32" x 31 1/2" (1220 x 800 mm)	15/64" - 6 mm
SH12WSH	48 1/32" x 31 1/2" (1220 x 800 mm)	15/32" - 12 mm
SH18WSH	48 1/32" x 31 1/2" (1220 x 800 mm)	45/64" - 18 mm
SH06WH	48 1/32" x 96 1/16" (1220 x 2440 mm)	15/64" - 6 mm
SH12WH	48 1/32" x 96 1/16" (1220 x 2440 mm)	15/32" - 12 mm
SH18WH	48 1/32" x 96 1/16" (1220 x 2440 mm)	45/64" - 18 mm

Each sheet is protected by a plastic masking. We recommend that you remove the masking when the job is done; not before.





INTERIOR MATERIALS

Plug and sockets



SC

Watertight plug and socket

Watertight plugs and sockets are available in 2 versions: For cable with a cross sectional area up of to 0,75 mm² (AWG18) max. 3 Amp. or a larger model for cables of up to 2,5 mm² (AWG12) max. 5 Amp. A rubber gasket and a synthetic cover are standard supply.

Material:

- Chrome plated brass

Type	Description
SC29	Watertight plug and socket with 2 pins, chromium plated brass
SC33	Watertight plug and socket with 3 pins, chromium plated brass
SC44	Watertight plug and socket with 4 pins, chromium plated brass
SC29L	Watertight plug and socket with 2 pins, large model, chromium plated brass
SC33L	Watertight plug and socket with 3 pins, large model, chromium plated brass
SC44L	Watertight plug and socket with 4 pins, large model, chromium plated brass

Locks and stays



LOCKDRC

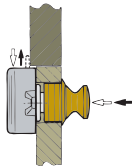

LOCKDRM

Push-button lock

Made of plastic with chromium or brass finish push-button.

Dimensions:

- 3 5/64" x 1 49/64" x 25/32" (78 x 45 x 20 mm)
- Panel thickness from 0.70in up to 0.78in (18 up to 20 mm)

Type	Description
LOCKDRC	Synthetic lock with chromium plated push-button
LOCKDRM	Synthetic lock with brass plated push-button

Stainless steel (AISI 316) hatch adjusters

Stainless steel (AISI 316). With brackets and knob.



UITSTEL

Type	Min. length	Max. length
UITSTELPH	7 ⁶¹ / ₆₄ " - 202 mm	14 ³¹ / ₆₄ " - 368 mm
UITSTELFE	10 ⁹ / ₃₂ " - 261 mm	19 ³ / ₃₂ " - 485 mm



LOCKS AND STAYS

Gas struts

There are many applications on board where the assistance of a gas strut will reduce the effort required. For example, heavy deck hatches or locker doors. VETUS gas struts are specifically designed for marine use. All external parts are made of stainless steel (AISI 316) or synthetic materials and the special seals guarantee long service life. When fitted vertically, make sure that the piston rod is pointing downward.

These gas-filled cylinders are supplied complete with fixings.

In order to calculate the maximum admissible weight which can be supported, the following data is required:

F = Force of the gas strut in N/m (see table)

G = Weight of the object to be lifted in N

W = Width of the object to be lifted in mm

The calculation goes as follows:

$$\text{Force in N/m} = \frac{G \times \frac{1}{2}W}{1000}$$

Example:

The weight (G) of a hatch is 11 kg (≈110 N). The width (W) of the hatch is 600 mm. This means that:

$$\frac{110 \times 300}{1000} = 33 \text{ N/m is needed to hold the hatch open.}$$

In the table we find that GASSP44 delivers 28.8 N/m, which means that an additional 4,3 N/m will have to be applied by the user.

In the case of 2 gas struts GASSP38, $18,9 \times 2 = 37,8$ N/m is delivered by the struts. In this case the user will have to push the hatch down with a force of 4,8 N/m.



GASSP..

Type	Force in N	Stroke S in mm	Force (F) in N/m	Length L in mm	Length L+S in mm
GASSP25	180 (40.5)	74 (2 7/8")	13,3	180 (7 1/8")	254 (10")
GASSP30	135 (30.35)	85 (3 3/8")	11,5	220 (8 5/8")	305 (12")
GASSP38	135 (30.35)	140 (5 1/2")	18,9	240 (9 1/2")	380 (15")
GASSP44	180 (40.5)	160 (6 1/4")	28,8	280 (11")	440 (17 1/8")
GASSP51	270 (60.7)	205 (8 1/16")	55,3	305 (12")	510 (20")

ACCESSORIES

Marine binoculars

These binoculars are specially designed for marine applications and the materials are carefully selected for their resistance to wind and weather. The lens coatings are specifically chosen for use on the water, where bright light, glare and UV radiation should be taken into account.

Robust, lightweight binoculars

The durable, lightweight housing and the relatively compact size make the BINO1 the ideal binoculars to have at hand at all times. The BK7 prisms and multi-coated lenses deliver very sharp images and the housing is fitted with a non-slip grip.

- BK7 prisms
- Magnification: 7x; Lens Ø 1 1/32" - 50 mm
- Water repellent
- Fixed focus and central variable focus
- Flexible eyecups for use with (sun) glasses
- Non-slip grip
- Robust housing
- Includes bag and strap and caps



BINO1

High-quality, waterproof binoculars

The BAK4 prisms create the sharpest and clearest images possible in a binocular in this price range. All lenses are multi-coated for long lasting protection. The superior prisms combined with large lens diameters make these binoculars very suitable for use in difficult conditions such as twilight or bad weather. The binoculars have a robust soft touch casing and ergonomic design making them easy and stable to hold.

- Superior quality prisms (BAK4) for the brightest images
- Magnification: 7x; Lens Ø 1 1/32" - 50 mm
- Waterproof and fog-free (filled with nitrogen)
- Fixed focus and central variable focus
- Flexible eyecups for use with (sun) glasses
- Ergonomic design and non-slip grip
- Includes bag and floatation strap and caps



BINO2

BK7 and BAK4 refer to the type of glass used for the prisms. The prisms bend the light image inside the binoculars. BK7 is borosilicate and BAK4 barium crown glass. The type of glass affects the sharpness and clarity of the image, BAK4 produces the best images with negligible distortion, whilst BK7 can result in a very slightly distorted image.



ALUMINIUM AND ZINC ANODES

Protection by means of anodes is a "must" for all metal parts under water. Therefore anodes are required for wooden, fibre glass and aluminium hulls. The material of V-Quipment zinc anodes is of the highest possible standard, the U.S. mil.-A-18001 K. specifications. Anodes which do not meet these specifications have little or no effect.

V-Quipment aluminium anodes consist of an aluminium-indium-zinc alloy Mil - A - 24779 (SH). All V-Quipment anodes are streamlined and mounted either with studs which can be welded to a steel hull, or with through-hull bolts for fibreglass and wooden boats. **We supply these studs and bolts separately.**

For vessels, which mostly cruise on inland (fresh) waters, we recommend aluminium anodes since aluminium has a greater difference of potential with other metals than zinc. This is very important, as fresh water provides a higher electrical resistance than salt water. For sailing on salt water or brackish water, we recommend the use of zinc anodes. Aluminium anodes also function well in salt water, but are sacrificed at a much faster rate. We do not recommend the use of magnesium anodes, as the difference of potential with other metals is too great which could cause damage to the hull paint, especially when sailing in brackish or salt waters.

Use the table below to select the right anode suitable for the type of water in which the boat is generally used.

Water type	Hull material				
	Wood	GRP	Aluminium	Steel	Sterndrive/ outboard
Fresh	Aluminium	Aluminium	Aluminium	Aluminium	Aluminium
Brackish	Zinc/ Aluminium	Zinc/ Aluminium	Zinc/ Aluminium	Zinc/ Aluminium	Aluminium
Salt	Zinc/ Aluminium	Zinc/ Aluminium	Zinc/ Aluminium	Zinc/ Aluminium	Aluminium

An annual inspection of the anode is needed, it should be replaced when the anode has been 50% sacrificed.

Type of anode material

Type	Type of alloy according to
Zinc	MIL-A-18001K
Aluminium	MIL-A-24779 (sh)

Bolt-on Series

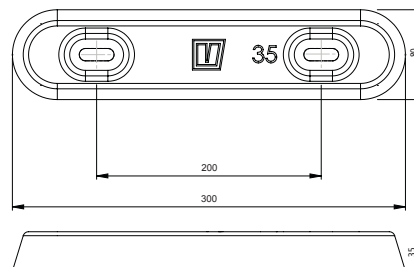
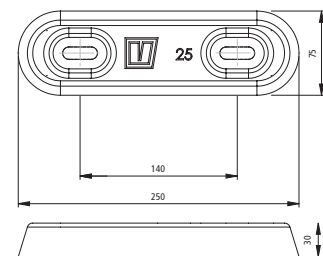



ALUMINIUM AND ZINC ANODES

Type	Description	Type of contour	Adequate Protects M ² paint / worn out paint / unpainted	Length inches	Width inches	Height inches	Nett Weight (lbs)
Zinc series							
ZINK8C	Hull anode, zinc MIL-A-18001K	Circular	12 / 6 / 3,5	3 9/16	3 9/16	1 25/32	2.42
ZINK15C	Hull anode, zinc MIL-A-18001K	Rectangular	14 / 7 / 3,5	5 29/32	2 3/4	1	2.42
ZINK25C	Hull anode, zinc MIL-A-18001K	Rectangular	24 / 12 / 6,5	9 27/32	2 15/16	1 3/16	5.51
ZINK35C	Hull anode, zinc MIL-A-18001K	Rectangular	40 / 20 / 10,5	11 13/16	3 5/32	1 3/8	10.36
Alu series							
ALU08C	Hull anode, aluminium MIL-A-24779 (sh)	Rectangular	12 / 6 / 3,5	3 9/16	3 9/16	1 25/32	1.03
ALU15C	Hull anode, aluminium MIL-A-24779 (sh)	Rectangular	14 / 7 / 3,5	5 29/32	2 3/4	1	1.08
ALU25C	Hull anode, aluminium MIL-A-24779 (sh)	Rectangular	24 / 12 / 6,5	9 27/32	2 15/16	1 3/16	2.42
ALU35C	Hull anode, aluminium MIL-A-24779 (sh)	Rectangular	40 / 20 / 10,5	11 13/16	3 5/32	1 3/8	4.62
ZKITS	Anode connection kit for steel hulls						
ZKITP	Anode connection kit for G.R.P. hulls						

When ordering, please always specify the material of the hull. All metal parts must have a direct contact with the anode. Therefore the bolts supplied for e.g. fibreglass hulls must have a wire-connection, so that contact can be made with the metal parts. (See drawing B). On fibreglass and wooden boats only the **metal** parts must be protected. For anodes type 8 you need **one** (1) connection kit and for types 15, 15S, 25, 25S and 35 you need **two** (2) of these. All V-Quipment anodes have a protective layer of paint at the mounting side to prevent damage to the paint work of your boat.

A How to install anodes on steel hulls

Anodes that are installed by means of studs are much easier to replace than anodes that are welded directly to the ship's hull. When ordering studs for a steel hull, please select the ZKITS bolt-on set.

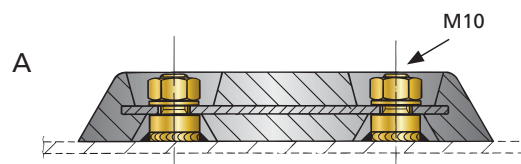

B How to install anodes on fibreglass and wooden hulls

For installing anodes on fibreglass and wooden hulls, please use our ZKITP bolt-on set. This ensures proper fixation and allows the anodes to be easily replaced when they are worn out.

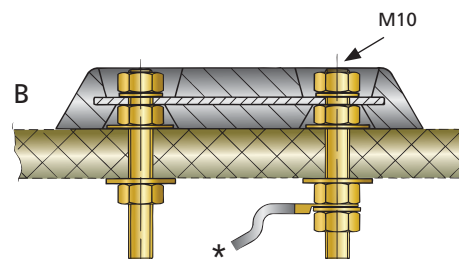

* Copper wire to connect parts to be protected.





ANODES - WELD-ON - ZINC AND ALUMINIUM

Weld-on Series



WOA0..A

WOA0..Z



WOA01.A

WOA01.Z

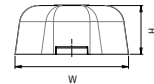
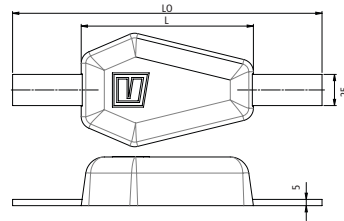
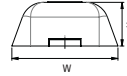
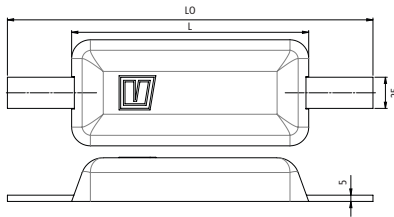

Type	Description	Type of contour	Length overall (LO=) (inches)	Length (L=) (inches)	Width (W=) (inches)	Height (H=) (inches)	Steel strap (inches)	Nett Weight (lbs)	Gross weight (lbs)
WOA000Z	Weld- on hull anode, zinc	Rectangular	7 ²⁵ / ₃₂	4 ⁷ / ₁₆	2 ³ / ₈	2 ¹ / ₃₂	7 ²⁵ / ₃₂ X 1 X 1 ¹ / ₈	1.25	1.49
WOA000A	Weld- on hull anode, aluminium	Rectangular	7 ²⁵ / ₃₂	4 ⁷ / ₁₆	2 ³ / ₈	2 ¹ / ₃₂	7 ²⁵ / ₃₂ X 1 X 1 ¹ / ₈	0.55	0.79
WOA001Z	Weld- on hull anode, zinc	Rectangular	7 ²⁵ / ₃₂	4 ⁷ / ₁₆	2 ⁷ / ₁₆	1	7 ²⁵ / ₃₂ X 1 X 3 ³ / ₁₆	1.94	2.35
WOA001A	Weld- on hull anode, aluminium	Rectangular	7 ²⁵ / ₃₂	4 ⁷ / ₁₆	2 ⁷ / ₁₆	1	7 ²⁵ / ₃₂ X 1 X 3 ³ / ₁₆	0.79	1.21
WOA002Z	Weld- on hull anode, zinc	Rectangular	11 ²³ / ₃₂	7 ⁷ / ₈	2 ³ / ₄	7 ⁷ / ₈	7 ²⁵ / ₃₂ X 1 X 3 ³ / ₁₆	3.46	4.07
WOA002A	Weld- on hull anode, aluminium	Rectangular	11 ²³ / ₃₂	7 ⁷ / ₈	2 ³ / ₄	7 ⁷ / ₈	7 ²⁵ / ₃₂ X 1 X 3 ³ / ₁₆	1.67	2.31
WOA003Z	Weld- on hull anode, zinc	Rectangular	11 ¹⁷ / ₃₂	8 ⁷ / ₃₂	2 ⁹ / ₁₆	1 ⁵ / ₃₂	11 ²³ / ₃₂ X 1 X 3 ³ / ₁₆	4.38	5
WOA003A	Weld- on hull anode, aluminium	Rectangular	11 ¹⁷ / ₃₂	8 ⁷ / ₃₂	2 ⁹ / ₁₆	1 ⁵ / ₃₂	11 ²³ / ₃₂ X 1 X 3 ³ / ₁₆	1.8	2.42
WOA004Z	Weld- on hull anode, zinc	Rectangular	11 ¹⁷ / ₃₂	7 ¹⁵ / ₃₂	3 ¹¹ / ₃₂	1 ³ / ₈	11 ²³ / ₃₂ X 1 X 3 ³ / ₁₆	5.99	6.61
WOA004A	Weld- on hull anode, aluminium	Rectangular	11 ¹⁷ / ₃₂	7 ¹⁵ / ₃₂	3 ¹¹ / ₃₂	1 ³ / ₈	11 ²³ / ₃₂ X 1 X 3 ³ / ₁₆	2.42	3.19
WOA010Z	Weld- on hull anode, zinc	Drop	9 ¹ / ₁₆	4 ²¹ / ₃₂	3 ¹ / ₁₆	1	9 ¹ / ₁₆ X 1 X 3 ³ / ₁₆	1.72	2.2
WOA010A	Weld- on hull anode, aluminium	Drop	9 ¹ / ₁₆	4 ²¹ / ₃₂	3 ¹ / ₁₆	1	9 ¹ / ₁₆ X 1 X 3 ³ / ₁₆	0.72	1.21
WOA011Z	Weld- on hull anode, zinc	Drop	9 ³ / ₄	5 ⁷ / ₁₆	3 ⁵ / ₈	1 ³ / ₈	9 ³ / ₄ X 1 X 3 ³ / ₁₆	3.43	3.96
WOA011A	Weld- on hull anode, aluminium	Drop	9 ³ / ₄	5 ⁷ / ₁₆	3 ⁵ / ₈	1 ³ / ₈	9 ³ / ₄ X 1 X 3 ³ / ₁₆	1.56	2.09
WOA012Z	Weld- on hull anode, zinc	Drop	9 ³ / ₄	6 ⁵ / ₁₆	3 ¹⁵ / ₁₆	1 ²¹ / ₃₂	9 ³ / ₄ X 1 X 3 ³ / ₁₆	5.42	5.95
WOA012A	Weld- on hull anode, aluminium	Drop	9 ³ / ₄	6 ⁵ / ₁₆	3 ¹⁵ / ₁₆	1 ²¹ / ₃₂	9 ³ / ₄ X 1 X 3 ³ / ₁₆	2.22	2.75



SHAFT ANODES IN ZINC

Shaft Series



ZINKAS

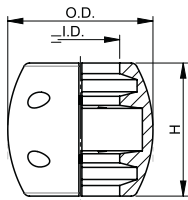

ZASA

Type	Description	I.D. (Shaft) (inches)	O.D. (inches)	H (inches)	Number of bolts	Nett Weight (lbs)
ZINKAS25C	Zinc shaft anode	1	2 7/32	2 7/32	2	1.12
ZINKAS30C	Zinc shaft anode	1 3/16	2 7/32	2 7/32	2	1.10
ZINKAS35C	Zinc shaft anode	1 3/8	2 17/32	2 19/32	4	1.36
ZINKAS40C	Zinc shaft anode	1 9/16	2 5/32	3 1/32	4	2.42
ZINKAS45C	Zinc shaft anode	1 25/32	2 5/32	3 1/32	4	2.02
ZINKAS50C	Zinc shaft anode	1 31/32	2 21/32	3 15/32	4	2.64
ZINKAS60C	Zinc shaft anode	2 3/8	3 15/16	3 15/16	4	4.12

Type	Description	I.D. (Shaft) (inches)	O.D. (inches)	H (inches)	Number of bolts	Nett Weight (lbs)
ZASA1C	Zinc shaft anode	1	2 1/8	2 5/32	2	0.88
ZASA1 1/4 C	Zinc shaft anode	1.25	2 13/32	2 3/8	2	1.16
ZASA1 1/2 C	Zinc shaft anode	1.5	2 3/4	2 19/32	4	1.63
ZASA1 3/4 C	Zinc shaft anode	1.75	2 5/32	2 3/4	4	2.35
ZASA2C	Zinc shaft anode	2	3 17/32	2 29/32	4	3.08



SAR

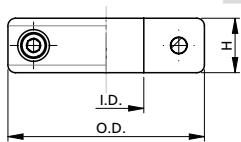

Type	Description	I.D. (Shaft) (inches)	O.D. (inches)	H (inches)	Nett Weight (lbs)
SAR25Z	Zinc shaft anode model "Ring"	1	2 9/16	2 3/32	0.68
SAR30Z	Zinc shaft anode model "Ring"	1 3/16	2 9/16	2 3/32	0.61
SAR35Z	Zinc shaft anode model "Ring"	1 3/8	2 9/16	2 3/32	0.55
SAR40Z	Zinc shaft anode model "Ring"	1 9/16	2 5/32	2 5/32	1.03
SAR45Z	Zinc shaft anode model "Ring"	1 25/32	2 5/32	2 5/32	0.97
SAR50Z	Zinc shaft anode model "Ring"	1 31/32	3 1/2	1	1.56

Rudder mounting Series



RAD

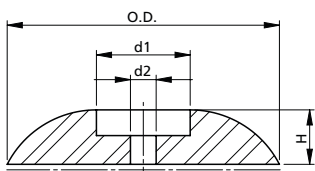

Type	Description	O.D. (inches)	d1 (inches)	d2 (inches)	H (inches)	Nett Weight (lbs)
RAD50Z	Zinc rudder anode model "Disc"	1 31/32	2 5/32	1/4	7/16	0.17
RAD70Z	Zinc rudder anode model "Disc"	2 3/4	7/8	11/32	1/2	0.51
RAD90Z	Zinc rudder anode model "Disc"	3 17/32	1 7/32	11/32	2 3/32	0.99
RAD110Z	Zinc rudder anode model "Disc"	4 11/32	1 3/16	7/16	2 3/32	1.54
RAD140Z	Zinc rudder anode model "Disc"	5 1/2	1 3/8	1 5/32	1 3/16	3.30





ALUMINIUM AND ZINC ANODES

Shaft anodes, for installation directly to the propeller shaft

VETUS shaft anodes are designed to create a perfect fit on the shaft. Even if the anode is eroded, it can't fall off. Shaft anodes are not recommended on high speed vessels. They create turbulence in the water flow around the propeller and as they erode, can cause imbalance in the propeller shaft. These problems do not occur when using the VETUS propeller nut with integrated zinc anode.

Zinc anode set for VETUS propeller shafts

Type	Description	O.D. Ø (inches)	H (inches)	Nett Weight (lbs)	Replacement anode only
SN25SET	Complete zinc anode set for Ø 25 mm shaft nut	1 ¹ / ₄	1 ¹ / ₂	0.26	SN25B
SN30SET	Complete zinc anode set for Ø 30 mm shaft nut	1 ²³ / ₃₂	2 ¹ / ₁₆	0.72	SN30B
SN35SET	Complete zinc anode set for Ø 35 mm shaft nut	1 ²³ / ₃₂	2 ¹ / ₁₆	0.63	SN35B
SN40SET	Complete zinc anode set for Ø 40 mm shaft nut	1 ¹⁵ / ₁₆	2 ¹⁷ / ₃₂	1.1	SN40B
SN45SET	Complete zinc anode set for Ø 45 mm shaft nut	2 ⁵ / ₁₆	2 ²⁹ / ₃₂	1.65	SN45B
SN50SET	Complete zinc anode set for Ø 50 mm shaft nut	2 ²⁷ / ₃₂	3 ³ / ₁₆	2.07	SN50B
SN60SET	Complete zinc anode set for Ø 60 mm shaft nut	3 ¹¹ / ₃₂	5 ¹ / ₁₆	8.37	SN60B



SN..B

SN..SET

Zinc anodes for VETUS bow thrusters



SET0148



SET0149



SET0150

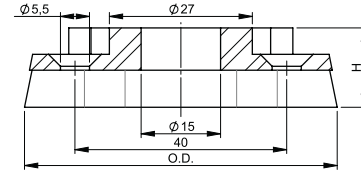
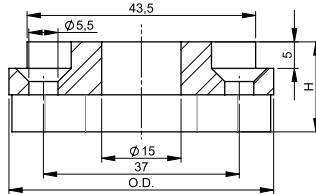
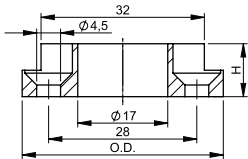

SET0151

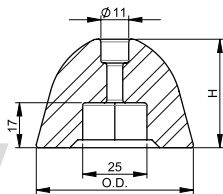

SET0152

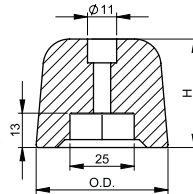

SET0153

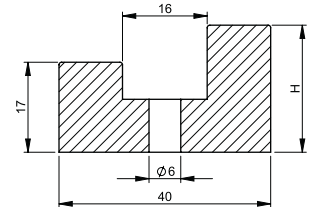

Type	Description	O.D. Ø (inches)	H (inches)	Nett Weight (lbs)
SET0148	Zinc anode for bow thruster 25 kgf, BOWA030	1 ¹ / ₂	1 ³ / ₃₂	0.08
SET0149	Zinc anode for bow thruster 35, 45, 55 kgf, BOWA036, 042, 057, BOWB042, 057	1 ³¹ / ₃₂	2 ¹ / ₃₂	0.30
SET0150	Zinc anode for bow thruster 60, 75, 80, 95 kgf, BOWA065, 076, 090, BOWB065, 076, 090	2 ³ / ₈	1 ⁹ / ₃₂	0.33
SET0151	Zinc anode for bow thruster 125, 130, 160 kgf, BOWA110	2 ⁵ / ₁₆	1 ⁵ / ₈	0.92
SET0152	Zinc anode for bow thruster 220, 230, 285, 300, 310 kgf	1 ¹⁵ / ₁₆	1 ⁵ / ₈	0.81



HOSES AND LUBRICANTS

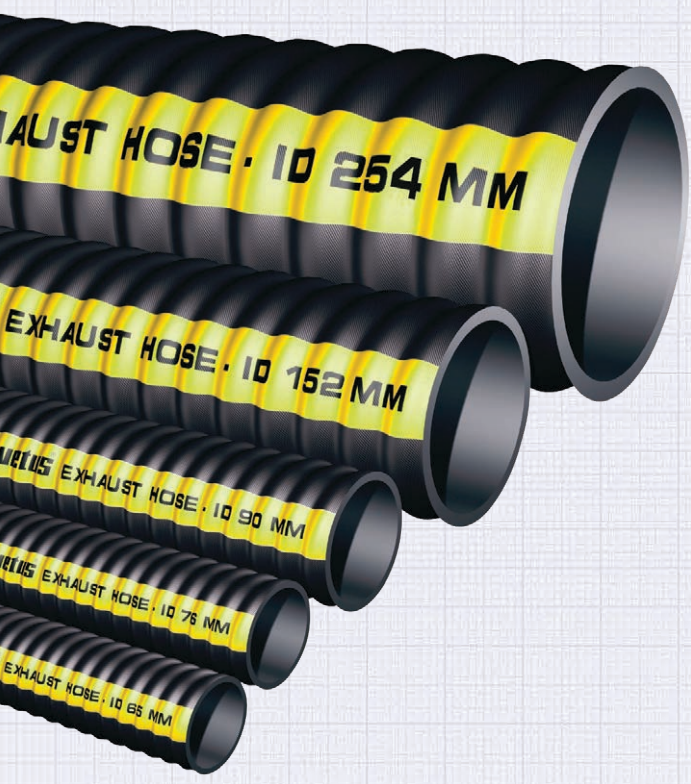

OVERVIEW OF HOSES

VETUS marine hoses are of a high quality and meet all the requirement of the current legislation for use on board. We have a very large range of hoses for all boat systems. Our hoses are highly flexible and extremely resistant to a variety of internal and external influences.

For available sizes see page 406.



DWHOSEB

Water hose type DWHOSEB

Temperature proof between 23 and +149°C (-5 and + 65°C)

This hose is made of transparent PVC with spiral inlay and is suitable for transportation of drinking water on board, both suction and pressure.



FUHOSEA

Fuel hose type FUHOSEA, FUHA115 and FHA115

For transportation of petrol and diesel fuels

The inside is made of NBR rubber and the outside of CR rubber. Can be used for transportation and as ventilation line. Particularly suitable for use with of petrol because of the low permeability.

Type FUHOSEA meets the CE standard: ISO 7840 marine fuel A1

Type FUHA115 meets the standard ISO 7840 marine fuel A1-15



FUHA115

FHA115..A



WWHOSE..A

Waste water hose

Type WWHOSE..A

An absolute must for waste water tanks

To be used for transportation of grey water. This type is made of white PVC with steel spiral inlay.



SAHOSE

Impermeable sanitary no-smell hoses type SAHOSE

An absolute must for toilets

These hoses are made of SBR rubber with inlays of woven synthetic fabric and steel spiral. Recommended especially for transportation of biological waste from (marine) toilets (black water).



BLHOSE

Ventilation hose

Type BLHOSE

For shell and extraction ventilators

Type BLHOSE is made of a woven glass fibre fabric, impregnated with PVC. Temperature resistant between -40° and + 212° F (-20° and +100°C).



VHOSE

Hose type VHOSE

Very flexible suction/pressure hose

This hose can connect the MOFI air vent to the extraction ventilator type 178. Available for Ø 6 or 7" (152 or 178 mm) hose connectors.

OVERVIEW OF HOSES

Hose for fluids in closed heating / cooling systems type CCHOSE

Excellent for fluids in air conditioning and central heating

Type CCHOSE is made of EPDM rubber with inlay of woven reinforcement fabric. Suitable for fluids in closed heating and/or cooling systems. When used with air conditioning units, an insulating sleeve (made of a combination of polythene and rubber with a closed cell structure) is required. Temperature resistant between 37° and 176°F (+3° and 80°C).



CCHOSE

Cooling water hose type MWHOSE

For all cooling fluids

Type MWHOSE is made of EPDM rubber with synthetic fabric and spiralled steel reinforcement. Suitable for cooling water, both suction and pressure (max. 2,5 bar), salt and fresh water. Temperature resistant between -22° and 248°F (30° and +120°C).

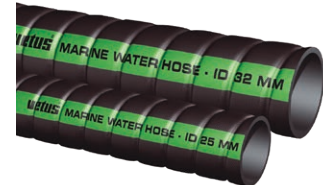

MWHOSE

Hose type HWHOSE

Ideal for use with calorifier and hot water systems

Type HWHOSE is made of EPDM rubber with an inlay of woven synthetic fabric. Suitable for drinking water and is temperature resistant between -22° and 320°F (30° and +160°C).



HWHOSE

Silicone hose type SIHOSE

Extremely high temperature resistant

Type SIHOSE is made of high grade silicone rubber with woven synthetic and an encapsulated steel spiral with an external smooth gloss finish. This flexible hose is highly resistant to ageing and suitable for a wide range of applications (exhaust, cooling and waste water hose). Temperature range of -65°, + 350°F (-54 to 177°C) (intermittently up to 482°F (250°C)).

Type SIHOSE meets all the requirements of the ISO13363 type Class B and SAE J 2006 R1 standards.

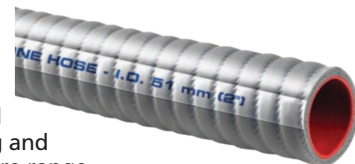

SIHOSE

Fuel filling hose type FFHOSE

Extremely flexible!

Type FFHOSE is made of NBR rubber with spiralled steel inlay. Suitable for petrol and diesel fuels. Resistant to temperatures of - 22° and + 212°F (-30° and +100°C). Type FFHOSE meets requirements of SAE J 1527 and the standard ISO 7840 marine fuel A2.



FFHOSE



OVERVIEW OF HOSES

Rubber exhaust hose type SLANG

Flexible and strong, saving valuable installation time

VETUS exhaust hose type SLANG is the most flexible hose because of the increased spiral reinforcement and the extremely supple rubber. The completely smooth internal surface of the hose will reduce back pressure in the engine. Exhaust hoses with an internal diameter up to Ø 6" (152 mm) have a bending radius of 1,5 x the diameter. Exhaust hoses with an internal diameter of more than Ø 152mm have a bending radius of twice the diameter.

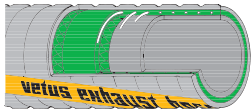

Temperature resistant between - 22° and + 212°F (-30° + 100°C) with brief temperatures of 39°F (115°C).

Type SLANG is approved by Lloyds Register and meets the requirements of the SAE J2006 R2 standard.



SLANG

An engine with a water injection exhaust elbow with an external diameter of 57 mm (2 1/4") may be connected to 2 3/8" (60 mm) VETUS exhaust hose. In this case VETUS waterlocks, mufflers, goosenecks and transom connections with a size of 2 3/8" (60 mm) can be used as well.

HCS and HCHDS (heavy duty) clamps are made of stainless steel. For more information about hose clamps see page 386.

DWBOSE..B

Type	Internal Ø inches (mm)	External Ø inches (mm)	Weight kg/m	Max. pressure bar	Bending radius inches (mm)	HCHD(S) clamp to suit	HCS clamp to suit	Roll length (m)
DWBOSE10B	3/8 (10)	5/8 (16)	0,16	7	20		HCS12	30
DWBOSE12B	1/2 (12)	11/16 (18)	0,18	7	25		HCS12 HCS16	30
DWBOSE16B	5/8 (16)	7/8 (22)	0,24	6	35		HCS16 HCS20	30
DWBOSE19B	3/4 (19)	1 (26)	0,32	5	50		HCS16 HCS20 HCS25	30
DWBOSE25B	1 (25)	1 5/16 (33)	0,53	5	60		HCS25 HCS32	30
DWBOSE28B	1 1/8 (28)	1 7/16 (36)	0,57	4,5	66	HCHD(S)034	HCS25 HCS32	30
DWBOSE30B	1 3/16 (30)	1 1/2 (38)	0,60	4,5	70	HCHD(S)037	HCS25 HCS32	30
DWBOSE32B	1 1/4 (32)	1 9/16 (40)	0,56	4,5	75	HCHD(S)037 HCHD(S)040	HCS32 HCS40	30
DWBOSE35B	1 3/8 (35)	1 3/4 (44)	0,73	4	80	HCHD(S)043	HCS32 HCS40	30
DWBOSE38B	1 1/2 (38)	1 7/8 (47)	0,80	4	90	HCHD(S)043 HCHD(S)047	HCS32 HCS40	30
DWBOSE40B	1 9/16 (40)	1 15/16 (49)	0,87	3	95	HCHD(S)047	HCS32 HCS40	10
DWBOSE45B	1 3/4 (45)	2 3/16 (55)	1,10	3	105	HCHD(S)051 HCHD(S)055	HCS40 HCS50	10
DWBOSE50B	1 15/16 (50)	2 3/8 (60)	1,20	3	125	HCHD(S)059	HCS50	10

FUHOSE - FUHA - FHA115..A

Type	Internal Ø inches (mm)	External Ø inches (mm)	Weight kg/m	Max. pressure bar	Bending radius inches (mm)	HCHD(S) clamp to suit	HCS clamp to suit	Roll length (m)
FUHOSE06A	1/4 (6)	1/2 (13)	0,16	10	1 (25)		HCS08 HCS12	30
FUHOSE08A	5/16 (8)	5/8 (16)	0,24	10	1 3/16 (30)		HCS12	30
FUHOSE10A	3/8 (10)	11/16 (18)	0,28	10	1 3/8 (35)		HCS12 HCS16	30
FUHOSE13A	1/2 (13)	7/8 (22)	0,39	10	1 5/16 (50)		HCS16 HCS20	30
FUHOSE16A	5/8 (16)	1 (25)	0,45	10	2 3/8 (60)		HCS16 HCS20	30
FUHOSE19A	3/4 (19)	1 1/8 (28)	0,52	10	3 1/8 (80)		HCS20 HCS25	30
FUHOSE25A	1 (25)	1 3/8 (35)	0,73	10	4 5/16 (110)	HCHD(S)034	HCS25 HCS32	30
FUHA11506	1/4 (6)	5/8 (16)	0,22	17	1/2 (13)		HCS08 HCS12	30
FUHA11508	5/16 (8)	11/16 (17)	0,24	17	7/8 (22)		HCS12	30
FUHA11510	3/8 (10)	11/16 (18)	0,30	17	7/8 (22)		HCS12 HCS16	30
FUHA11513	1/2 (13)	7/8 (23)	0,38	17	1 3/8 (35)		HCS16 HCS20	30
FHA11506A	1/4 (6)	5/8 (15,6)	0,22	17,2	1/2 (13)		HCS8	76
FHA11508A	5/16 (8)	21/32 (16,7)	0,24	17,2	7/8 (22)		HCS12	76
FHA11510A	3/8 (10)	23/32 (18,4)	0,30	17,2	7/8 (22)		HCS12	76
FHA11513A	1/2 (13)	7/8 (22,6)	0,38	12,1	1 3/8 (35)		HCS16	76

OVERVIEW OF HOSES

WWHOSE..A

Type	Internal Ø inches (mm)	External Ø inches (mm)	Weight kg/m	Max. pressure bar	Bending radius inches (mm)	HCHD(S) clamp to suit		HCS clamp to suit		Roll length (m)
WWHOSE16A	5/8 (16)	7/8 (22)	0,23	6	1 3/8 (35)			HCS16	HCS20	30
WWHOSE19A	3/4 (19)	1 (26)	0,32	5	1 15/16 (50)			HCS16	HCS20	30
WWHOSE25A	1 (25)	1 5/16 (33)	0,53	5	2 3/8 (60)			HCS25	HCS32	30
WWHOSE38A	1 1/2 (38)	1 7/8 (47)	0,80	4	3 9/16 (90)	HCHD(S)043	HCHD(S)047	HCS32	HCS40	30
WWHOSE45A	1 3/4 (45)	2 3/16 (55)	1,10	3	4 1/8 (105)	HCHD(S)051	HCHD(S)055	HCS40	HCS50	10

SAHOSE

Type	Internal Ø inches (mm)	External Ø inches (mm)	Weight kg/m	Max. pressure bar	Bending radius inches (mm)	HCHD(S) clamp to suit		HCS clamp to suit		Roll length (m)
SAHOSE16	5/8 (16)	1 (26)	0,45	3	1 15/16 (50)			HCS16	HCS20 HCS25	20
SAHOSE19	3/4 (19)	1 1/8 (29)	0,55	3	2 9/16 (65)			HCS20	HCS25	20
SAHOSE25	1 (25)	1 7/16 (36)	0,72	3	2 15/16 (75)	HCHD(S)034		HCS25	HCS32	20
SAHOSE38	1 1/2 (38)	1 7/8 (48)	1,15	3	3 15/16 (100)	HCHD(S)047		HCS32	HCS40	20
SAHOSE102	4 (102)	4 1/2 (115)	3,86	3	9 13/16 (250)	HCHD(S)112		HCS110		10

BLHOSE

Type	Internal Ø inches (mm)	External Ø inches (mm)	Weight kg/m	Max. pressure bar	Bending radius inches (mm)	HCHD(S) clamp to suit		HCS clamp to suit		Roll length (m)
BLHOSE310A	3 1/8 (79)	3 11/32 (85)	0,2	-	1 7/8 (47)					10
BLHOSE410A	4 (102)	4 1/14 (108)	0,2	-	2 13/32 (61)					10

VHOSE

Type	Internal Ø inches (mm)	External Ø inches (mm)	Weight kg/m	Max. pressure bar	Bending radius inches (mm)	HCHD(S) clamp to suit		HCS clamp to suit		Roll length (m)
VHOSE152	6 (152)	6 1/4 (158)	0,94		5 29/32 (150)					
VHOSE178	7 1/16 (180)	7 5/16 (186)	1,09		7 1/16 (180)					

CCHOSE

Type	Internal Ø inches (mm)	External Ø inches (mm)	Weight kg/m	Max. pressure bar	Bending radius inches (mm)	HCHD(S) clamp to suit		HCS clamp to suit		Roll length (m)
CCHOSE16	5/8 (16)	1 3/16 (30)	0,54	1.5	4 7/16 (112)					20
CCHOSE25	1 (25)	1 9/16 (39)	0,76	1.5	6 7/8 (175)					20

MWHOSE

Type	Internal Ø inches (mm)	External Ø inches (mm)	Weight kg/m	Max. pressure bar	Bending radius inches (mm)	HCHD(S) clamp to suit		HCS clamp to suit		Roll length (m)
MWHOSE19	3/4 (19)	1 1/8 (28)	0,39	2.5	1 1/8 (29)			HCS20	HCS25	20
MWHOSE25	1 (25)	1 5/16 (34)	0,51	2.5	1 1/2 (38)			HCS25	HCS32	20
MWHOSE32	1 1/4 (32)	1 5/8 (41)	0,71	2.5	1 7/8 (48)	HCHD(S)040		HCS32	HCS40	20
MWHOSE38	1 1/2 (38)	1 7/8 (47)	0,88	2.5	2 1/4 (57)	HCHD(S)043	HCHD(S)047	HCS32	HCS40	20
MWHOSE51	2 (51)	2 3/8 (60)	1,15	2.5	3 1/16 (77)	HCHD(S)059		HCS50		20

HWHOSE

Type	Internal Ø inches (mm)	External Ø inches (mm)	Weight kg/m	Max. pressure bar	Bending radius inches (mm)	HCHD(S) clamp to suit		HCS clamp to suit		Roll length (m)
HWHOSE13	1/2 (13)	29/32 (23)	0,36	8	3 3/4 (95)			HCS16	HCS20	10
HWHOSE16	5/8 (16)	1 (26)	0,40	8	4 11/32 (110)			HCS16	HCS20 HCS25	10



OVERVIEW OF HOSES

SIHOSE

Type	Internal Ø inches (mm)	External Ø inches (mm)	Weight kg/m	Max. pressure bar	Bending radius inches (mm)	HCHD(S) clamp to suit	HCS clamp to suit	Roll length (m)
SIHOSE25	1 (25)	1 ³ / ₈ (35)	0,60	5.0	2 ⁷ / ₁₆ (62)	HCHD034	HSC25	20
SIHOSE32	1 ¹ / ₄ (32)	1 ⁵ / ₈ (41)	0,73	4.5	3 ¹ / ₈ (80)	HCHD040	HSC32	20
SIHOSE38	1 ¹ / ₂ (38)	1 ⁷ / ₈ (47)	0,85	4.0	1 (26)	HCHD043	HSC40	20
SIHOSE51	2 (51)	2 ³ / ₈ (61)	1,31	4.0	5 ⁷ / ₈ (150)	HCHD059	HSC50	20
SIHOSE63	2 ¹ / ₂ (63)	2 ¹⁵ / ₁₆ (74)	1,60	3.5	7 ¹ / ₂ (190)	HCHD073	HSC60	20
SIHOSE76	3 (76)	3 ⁷ / ₁₆ (87)	2,06	3.5	8 ⁷ / ₈ (225)	HCHD085	HSC75	20
SIHOSE102	4 (102)	4 ⁷ / ₁₆ (113)	2,70	2.0	14 ³ / ₁₆ (360)	HCHD0112	HSC110	20

FFHOSE

Type	Internal Ø inches (mm)	External Ø inches (mm)	Weight kg/m	Max. pressure bar	Bending radius inches (mm)	HCHD(S) clamp to suit	HCS clamp to suit	Roll length (m)
FFHOSE38	1 ¹ / ₂ (38)	1 ¹⁵ / ₁₆ (50)	1,1	4	3 (76)	HCHD(S)047	HCS40	20
FFHOSE51	2 (51)	2 ¹ / ₂ (63)	1,5	4	4 (102)	HCHD(S)059 HCHD(S)063	HCS50 HCS60	20

SLANG

Type	Internal Ø inches (mm)	External Ø inches (mm)	Weight kg/m	Max. pressure bar	Bending radius inches (mm)	HCHD(S) clamp to suit	HCS clamp to suit	Roll length (m)
SLANG30	1 ³ / ₁₆ (30)	1 ¹ / ₂ (38)	0,55	4	1 ³ / ₄ (45)	HCHD(S)037	HCS25 HCS32	20
SLANG40	1 ⁹ / ₁₆ (40)	1 ⁷ / ₈ (48)	0,79	4	2 ³ / ₈ (60)	HCHD(S)047	HCS32 HCS40	20
SLANG45	1 ³ / ₄ (45)	2 ¹ / ₁₆ (53)	0,88	4	2 ¹¹ / ₁₆ (68)	HCHD(S)051	HCS40 HCS50	20
SLANG50	2 (51)	2 ⁵ / ₁₆ (59)	1,0	4	3 ¹ / ₁₆ (77)	HCHD(S)059	HCS40 HCS50	20
SLANG57	2 ¹ / ₄ (57)	2 ⁹ / ₁₆ (65)	1,1	3.3	3 ³ / ₈ (86)	HCHD(S)063	HCS50 HCS60	20
SLANG60	2 ³ / ₈ (60)	2 ¹¹ / ₁₆ (68)	1,2	3.3	3 ⁹ / ₁₆ (90)	HCHD(S)063 HCHD(S)068	HCS50 HCS60	20
SLANG65	2 (51)	2 ⁷ / ₈ (73)	1,3	3.3	3 ⁷ / ₈ (98)	HCHD(S)068 HCHD(S)073	HCS60	20
SLANG75	3 (76)	3 ⁵ / ₁₆ (84)	1,4	3.3	4 ¹ / ₂ (114)	HCHD(S)085	HCS75	20
SLANG90	2 (51)	3 ⁷ / ₈ (98)	1,9	2	5 ⁵ / ₁₆ (135)	HCHD(S)097	HCS90	20
SLANG100	4 (102)	4 ⁵ / ₁₆ (110)	2,3	2	6 (153)	HCHD(S)104	HCS90 HCS110	20
SLANG110	4 ⁵ / ₁₆ (110)	4 ¹¹ / ₁₆ (119)	2,8	2	6 ¹ / ₂ (165)	HCHD(S)112	HCS110	20
SLANG125	5 (127)	5 ³ / ₈ (137)	3,3	2	7 ¹ / ₂ (191)	HCHD(S)130	HCS130	20
SLANG150	6 (152)	6 ⁷ / ₁₆ (163)	4,4	2	9 (228)	HCHD(S)162	HCS150	20
SLANG200	8 (203)	8 ⁹ / ₁₆ (218)	6,8	2	16 (406)	HCHD(S)213	HHCS200	12
SLANG250	10 (254)	10 ⁵ / ₈ (270)	8,5	2	20 (508)	HCHD(S)260	HHCS250	12
SLANG300	12 (305)	12 ¹¹ / ₁₆ (323)	10,8	2	23 ⁷ / ₈ (606)	HCHD(S)300	HHCS300	12

LUBRICANTS

VETUS has a wide range of high quality lubricants for marine diesel engines, gearboxes, hydraulic steering, power hydraulic systems and bow thrusters. A special line for 2-stroke and 4-stroke outboards and for sterndrives is also available. Multipurpose lubricants complete this impressive range of lubricants for all marine applications!



Marine diesel engine mineral oil

Suitable for most marine diesel engines and generator sets, with or without turbo charging.

Specifications
API CI-4/SL

VMD15

Type	Specification
VMD151	1 L 15W-40
VMD154	4 L 15W-40
VMD1520	20 L 15W-40



Marine diesel engine synthetic oil

Specially developed for high output, modern marine diesel engines and generator sets.

Specifications
API CI-4

VMD10

Type	Specification
VMD101	1 L 10W-40
VMD104	4 L 10W-40



Hypoid gear oil for drive legs

Suitable for bow thrusters drive legs, anchor windlass gearboxes and outboard engine drive legs.

Specifications
API GL-5

VBT

Type	Specification
VBT05	500 ml 80W-90



Transmission oil

Suitable for all marine transmissions where automatic transmission fluid (ATF) Dextron IID or Suffix A is specified.

Specifications
DEXRON II-D

VTF1

Type	Specification
VTF1	1 L



Hydraulic steering oil

Very thin, hydraulic steering oil for optimal functioning in all temperatures.

Specifications
DIN 51524

VHS

Type	Specification
VHS1	1 L 22 CST



Hydraulic oil

For power hydraulic systems. This product has particularly high EP and corrosion resistant properties.

Specifications
DIN 51524-2 HLP

VHT

Type	Specification
VHT1	1 L ISO VG 46
VHT4	4 L ISO VG 46
VHT20	20 L ISO VG 46

LUBRICANTS



2-Stroke outboard engine oil

Suitable for 2-stroke outboard engines.

VTS

Specifications

NMMA (BIA) TC-W3

Type	Specification
VTS1	1 L



4-Stroke outboard engine oil

Recommended for the lubrication of high speed 4-stroke outboard engines under heavy duty load.

VFS

Specifications

NMMA FC-W

Type	Specification
VFS251	1L 25W-40
VFS101	1L 10W-30



Teflon Spray

A widely applicable lubricant for cleaning, lubricating and protection against dirt and moisture.

VTEFS

Type	Specification
VTEFS	400 ml



Shipping Grease

A lithium soap thickened grease with excellent water-displacing qualities even in salt water.

VSG

Specifications

N.L.G.I. Klasse 2, DIN 51 502, KP 2 K-30

Type	Specification
VSG	600 gr



Stern drive oil

Specially developed for transmissions used in watersports such as outboard drive legs and stern drives. Outstanding moisture resistance, excellent protection against rust and corrosion.

VSD

Specifications

API: GL-4/5 SAE 75W-90

Type	Specification
VSD7505	500 ml 75W-90



Organic Coolant -38°C

A modern organic coolant for all types of engines made of cast iron, steel or aluminium. Available in 1 litre (VOC1) and 4 litres (VOC4).

VOC

Type	Specification
VOC1	1 L
VOC4	4 L



Sump-pump

This pump is for emptying the engine sump or gearbox. Comes complete with tubing.

CARTERP

Type	Specification
CARTERP	Manual sump-pump, brass, incl. tubing

SPARE PARTS

VETUS products are manufactured to the highest quality standards. Using only genuine VETUS spare parts protects your investment and maintains the unique warranty conditions. Our dealer network is committed to deliver the right part any time and place you need it.

The VETUS Parts Finder; easy access to spare parts codes

This tool found on the VETUS website gives easy access to spare part codes for VETUS engines and equipment, both current and older models. So when looking for parts, always check our parts finder to avoid mistakes before ordering. Please keep in mind that not all the parts shown are still available or in stock. Your local dealer can inform you about availability.

Why VETUS parts?

- Genuine parts maintain the unique VETUS warranty conditions
- Huge stocks and fast delivery
- Available through our extensive dealer network
- Original spare parts have proven quality

THE VETUS PARTS FINDER

Go to the VETUS Parts Finder!



The button of the Parts Finder is shown on every product page on the website!

HOME > SPARE PARTS

WELCOME TO THE NEW VETUS PARTS FINDER!

This tool gives easy access to spare part codes for VETUS engines and equipment, both current and older models. So when looking for parts, always check our parts finder to avoid mistakes before ordering. Please keep in mind that not all the parts shown are still available or in stock. Your local dealer can inform you about availability.

Why VETUS parts?

- Genuine parts maintain the unique VETUS warranty conditions
- Huge stocks and fast delivery
- Available through our extensive dealer network
- Original spare parts have proven quality

[BACK TO MAIN PRODUCTS](#)

ENGINES

ELEC

HOME > SPARE PARTS

WELCOME TO THE NEW VETUS PARTS FINDER!

This tool gives easy access to spare part codes for VETUS engines and equipment, both current and older models. So when looking for parts, always check our parts finder to avoid mistakes before ordering. Please keep in mind that not all the parts shown are still available or in stock. Your local dealer can inform you about availability.

Why VETUS parts?

- Genuine parts maintain the unique VETUS warranty conditions
- Huge stocks and fast delivery
- Available through our extensive dealer network
- Original spare parts have proven quality

[BACK TO MAIN PRODUCTS](#)

ENGINES

You are now in the section of the Parts Finder for Engines. Click on the dropdown below and select a model.

MODEL VETUS M4.45 Marine Diesel Engine ▼



Show: RCG ▼

[BACK](#)



SPARE PARTS

VETUS Diesel Engine Spare Parts

All engine spare parts are manufactured to the same quality standards as the original engine and subject to strict testing procedures. Thanks to short lines of communication with our partners and advanced testing facilities, we can offer high quality and the most extensive warranty conditions in the market.

VETUS Diesel service kit

Regular engine maintenance and daily checks will help to avoid unpleasant surprises whilst out on the water! To make your life easier, a VETUS Diesel Service kit is available for nearly every type VETUS marine diesel engine. Please have your type number available when you order your kit with your dealer to make sure you order the right service kit. This number can be found on the sticker on your engine.

The following items are included in the spare parts kit

- Oil filter
- Fuel filter
- V-belt
- Impeller
- Gasket





VETUS Service network

As the owner of a VETUS engine/product we hope you can enjoy your time on the water without any problems. Regular service and maintenance is, of course, very important, nevertheless even the most reliable products can sometimes develop a problem. With the VETUS worldwide service network we are able to help you with your unexpected issues. We can help you as quickly as needed. Most spare parts are in stock in our central warehouses, from O-rings to alternators and from oil filters to heat exchangers, for both current and discontinued VETUS engines and products alike.

















INDEX

A	Accumulator tank	145	Clear view screens	282	
	Acoustic materials	56-60	Cleats	367	
	Air suction vents	298-299	Combi-γ	226	
	Air vent fitting	374, 384	Connection cables (thrusters)	193	
	Air vents (anti siphon)	96-97	Connection kit for tanks	131-132	
	Anchor tensioner	339	Connection parts (steering systems)	255	
	Anchor windlasses	302-329	Constant velocity joint	70	
	Anchors	336	Control gear windlasses	330-331	
	Anodes	398-402	Control panel DC thrusters	192	
	Automatic change-over device	231	Control panel waste water tank	163	
B	Ball valves	164, 166, 376-379	Control panels (hydraulic thrusters)	196	
	Ball-joint	49	Control panels bow and stern thrusters	190-192	
	Batteries	229-230	Control panels toilets	156	
	Battery boxes	228	Cooling water strainers	52-55	
	Battery cables	234	Copper tubing	255	
	Battery chargers	227	Couplings (flexible)	66-69	
	Battery main switches	194	Cowl ventilators	295-297	
	Battery maintainer	228	Custom made glazing	274-278	
	Battery selector switch	232	Cutlass bearings	80	
	Battery splitter	228	Cylinders	246-248	
	Battery switches	232	D Deck entries	385	
	Battery terminals	234	Deck hatches	268-273	
	Bearings	80	Deck ventilators	290-291	
	Bilge pump waste water	163	Detectors	117	
	Bilge pumps	387	Diesel engines	14-40	
	Bilge water/oil separator	55	Diesel filters	127	
	Binoculars	397	Diode splitter	228	
	Boarding ladders	363-365	Dorade boxes	300	
	Boat seats	346-354	Drinking water tanks	139-140	
	Boilers	142-143	Drive for propeller shaft	70-71	
	Bollards	367	Dual station units	49	
	BOW PRO thrusters	178-179	E Electric remote control (thrusters)	192	
	Bow rollers	334-335	Electronic engine controls	46-48	
	Bow thruster accessories	193-195	Emergency stop	194	
	Bow thruster anodes	402	Engine instrument panels	105-108	
	Bow thruster control panels	190-192	Engine mountings (flexible)	50-51	
	Bow thruster tunnels	195	Engine remote controls	44-48	
	Bow thrusters	175-185	Engine shut-off	49	
	Bow thrusters (hydraulic)	186-187	Engines	14-40	
	Breather nipples	384	Escape hatches	268-273	
	By-pass valve	254	Exhaust transom connectors	99	
C	Cabin entries	276-277	Extended runtime thrusters	182	
	Cable clamp	49	Extraction pipes for waste water tanks	167	
	Cable lugs	234	Extraction ventilators	293-294	
	Cable steering	388-389	F Fans (electric)	293	
	Cable tags	234	Filters ("no-smell")	133-134	
	Cable terminals	234	Filters (sea water strainer)	52-55	
	Cables (battery)	234	Filters (water separator/fuel filter)	123-127	
	Calorifiers	142-143	Fireport	118	
	Capstans	302-329	Fittings	374-386	
	Chain	338-339	Fittings (angled)	164	
	Chain snubbers	339	Flexible couplings	66-69	
	Chain stoppers	335	Flexible tanks	141, 162	
	Change-over device	231	Flush deck hatch	269	
	Circuit breaker	331	Fly bridge hatch	277	

INDEX

Follow up steering system	257-258	M Manifold	377
Foot switches	331	Mechanical engine controls	44-45
Fuel "Splash-Stop"	128	Mixer	100
Fuel filters	123-127	Mounting brackets	60
Fuel Safe	134	Mountings for waterlocks	100
Fuel tanks	129-130	Mufflers	94
Fuses & fuse holder	233	Mushroom ventilators	291
G Gas detector	117	N Navigation lights	373
Gas struts	397	No smell filters (waste water)	133-134
Gas/water separators	98	Non-return valve (hydraulic)	254
Gauges and indicators	108-111	Non-slip deck covering	395
Generator sets	223-224	No-smell filters (fuel)	162
Goosenecks	94-95	Nylon hose	254
H Handles	337	O Oil cooler	214
Handrail	366	Oil/water separator	55
Hatch adjusters	396	Oils	409-410
Hatch lifter (hydraulic)	286	Outboard steering systems	251
Hatches	268-273	P Parallel switch for thrusters	194
Heating element heaters/calorifiers	148	Pedestals	355-361
Hinged doors	277	Petrol filter	127
Horns	362-363	Petrol vapour detector	117
Hose adaptors	165	Plugs and sockets	396
Hose clamps	386	Poly-wood sheets	395
Hose connectors	100, 374-381	Portholes	263-267
Hose fittings	374-381	Power packs (diesel)	196
Hoses	404-408	Power packs (electric)	217
Hydraulic bow and stern thrusters	186-187	Power packs (electro-hydraulic)	28
Hydraulic brackets	202	Pressurized water systems	144-145
Hydraulic load sensing en control devices	205	Propeller shaft anodes	402
Hydraulic oil	409	Propeller shafts & tubes	72-77
Hydraulic outboard steering	250-251	Propellers	78-79
Hydraulic power steering	212-214	Proportional valves	207
Hydraulic powerpack	28	Pump flanges	253
Hydraulic propulsion	27, 215-216	Pumps	387
Hydraulic pumps	200-201	Pumps (pressurized water system)	145
Hydraulic tanks	203-204	Push-pull cables	49
Hydraulic thurster control joysticks	206	R Rainsensor (automatic)	285
Hydraulic windlasses	218	Relays	233
I Ignition protected thrusters	183	Remote control steering	257-258
Inflatable boats	391-394	Remote controls for engines	44-45
Inspection lids	146, 167	Remote controls for thrusters	192
Inspection port	165	Remote controls for windlasses	332-333
Installation kit fresh water	147	Retractable bow thruster	184
Installation kit waste water tanks	164	RIB	394
Installation kit water tanks	147	Rimdrive	180
Instruments (dashboard)	108-111	Rope	339
Inverters	225	Rubber bearings	80
J Joystick (hydraulic thurster control)	206	Rubbing strakes	368-371
Joystick manoeuvring & steering system	188-189	Rudder feedback unit	114
L Ladders	363-365	Rudder position indicators	114
Level sensors	146	Rudders	256-257
Level switch	387	S Saildrive	26
Locks and stays (push-button)	396	Saildrive kit	26
Lubricants	409-410	Sani-processor	157-158

INDEX

Screenwash system	285	Tensioners	335, 339	
Searchlights	372	Terminals (battery)	234	
Seat covers	353	Thermostatic mixer	148	
Seat pedestals	355-359	Through-hull fittings	374-386	
Seats	346-354	Time delay device (thrusters)	193	
Selection guide windlasses and accessories	340-341	Toilets	153-156	
Shackles	337	T-Pieces	381	
Shaft anodes	402	Transom connectors	99	
Shafts	72	Tunnels (thrusters)	195	
Shell ventilators	292	U Ultrasonic sensor	163	
Shore power protector	231	V Valves	168	
Shut-off control	49	Valves (proportional)	207	
Skin fittings	374-386	Vent valve	163	
Snubbers	339	Ventilation hatches	268-273	
Solar battery charger	231	Ventilators	290-294	
Solas Engines	40	W Waste water connectors	168	
Solenoids	233, 331	Waste water control panel	163	
Sound insulation	56-60	Waste water pump	163	
Spare parts	411-412	Waste water tank accessories	163-168	
Spin-on filter	123	Waste water tanks	159-162	
Splash-Stop (fuel)	128	Water heaters/calorifiers	142-143	
Stabilizers	210-211	Water lubricated stern gear	72-77	
Stanchions	366	Water mixer	100	
Stantion sockets	366	Water pressure systems	144	
Steering pumps	245	Water scoops	374, 376, 378	
Steering system configurations	244	Water separators/filters	123-126	
Steering systems commercial craft	249-250	Water strainers	52-55	
Steering systems for outboard engines	251-252	Waterlocks	86-93	
Steering wheel adjusters	253	Webbing tensioner	335	
Steering wheels	239-243	Windlasses	302-329	
Stern gear	64-65	Windlasses (hydraulic)	218	
Stern thrusters	181	Windlasses accessories	330-339	
Stopper tensioner	335	Windlasses controls	330-333	
Strainers	52-55	Windscreen washer system	284	
Suction pipes	148	Windscreen wiper arms and blades	280-282	
Sump pump	410	Windscreen wiper control panel	285-286	
Sunroof	278	Windscreen wiper motor	279	
SUP board	394	Windscreen wipers	279-286	
Superyacht windlasses and capstans	342-343	Windscreen wipers heavy duty	283-284	
Swivel	337	Windscreens	278	
Switch panels	115-116	Wireless remote control	192	
Switches	258	Wireless remote controls autoanchor	332	
T Table pedestals	360-361			
Tables	360			
Tank fittings and nipples	164			
Tank fresh	162			
Tank gauges and senders	112-113			
Tank sensors	113			
Tanks	129-130, 139-140, 159-162			
Tanks drinking water	139-140			
Tanks flexible	141, 162			
Tanks for fuel	129-130			
Tanks senders	112-113			
Tanks waste water	159-162			