



DUTTON LAINSON COMPANY

MANUFACTURED IN THE USA SINCE 1886



StrongArm®



GOLDENROD®



NEW DLx PULLING WINCHES

Building on the original DLx winches introduced earlier, the new fully-covered (FC) models take it to an even higher level.

A three-piece cover provides a more streamlined look and protects interior components, while an all-black handle and covered ratchet pawl complete the look.

Five sizes are available, including a 2-speed 2600 lb model.

3-piece high-impact cover with removable hinged top section

Black plated handle with premium cushioned grip

Covered ratchet pawl

Winch strap with hook installed

DLx1900FC



DLx1200FC



DLx2600FC



Shown with top cover open



DLx1200



DLx2300



DLx Winch Specs	Model	Rated Capacity (1)	Drum Hub Dia.	Gear Ratio	Handle Length	Max Mech. Adv.	Maximum Drum Capacity	
							Cable (2)	Strap
	DLx1200 DLx1200FC	1200 lb/544 kg	7/8"	4.4:1	7"	56	7/32" x 56'	31'
	DLx1500 DLx1500FC	1500 lb/680 kg	7/8"	4.4:1	9-1/2"	74	1/4" x 40'	31'
	DLx1900 DLx1900FC	1900 lb/862 kg	1-1/8"	5.4:1	9-1/2"	73	9/32" x 49'	38'
	DLx2300 DLx2300FC	2300 lb/1043 kg	1-1/8"	7.2:1	9-1/2"	95	5/16" x 39'	38'
	DLx2600FC	2600 lb/1179 kg	1-1/8"	17.3:1 / 5.4:1	9-1/2"	229	5/16" x 39'	38'

(1) Capacity based on direct line pull on the third layer of line on the drum. Capacity is reduced as the line builds up on the drum.

(2) Drum capacity based on cable size listed. (Cable not included.) Cable size listed may be too large to be practical for some applications.

NEW DLX TONGUE JACKS



Following the success of the original version, the DLx tongue jack line has been expanded with the addition of three new models.

The premium (P) round tube model features a wide (3") wheel for additional surface area and maneuverability.

Two new square tube models are also available, with the wide wheel (SW) or a unique articulating foot (SF).

DLx Jack Specs	Model	Capacity	Mounting*	Handle Type	Wheel	Travel	Maximum Tongue Height	Swivel Pin Dia.
	DLx	1500 lb/680 kg	Bolt-on	Side	8"	12"	28-1/2"	1/2"
	DLx-P	1500 lb/680 kg	Bolt-on	Side	8" (3" wide)	12"	28-1/2"	1/2"
	DLx-SW	1700 lb/771 kg	Bolt-on	Side	8" (3" wide)	12"	29-1/2"	1/2"
	DLx-SF	2000 lb/907 kg	Bolt-on	Side	Foot	12"	29-1/2"	1/2"



*All bolt-on jacks above fit tongues up to 3" x 5".

PULLING WINCHES

D-L pulling winches are best suited for boat trailer and other horizontal pulling applications which require the freewheeling feature of ratchet type winches.

D-L pulling winches are available in models from 400 lb to 3,500 lb capacity. Models from DL1402A to DL3200A have a **patented*** **reversible ratchet** to allow cranking cable or strap onto the drum in either direction. A hand brake to help control the Freewheel mode is optional on heavy duty models and standard equipment on the DL3500B.

For hand winch selection guidelines, see page 26.

* U.S. Pat. 6,116,580 and Canadian Pat. 2,378,538.

DL1402A thru DL3200A
DLx1200 thru DLx2300

DL1402ASC, DL1802ASC,
DL1800ASC and
DLB1500ASC

Design patents:
German 40001197.2
France 00 0665



Manufactured in the

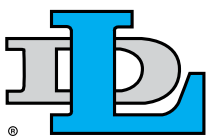

See This?



Visit
[www.dutton-lainson.com/
help-videos](http://www.dutton-lainson.com/help-videos)
to watch a video
of that product in action!

Pulling Winches with Ratchet Feature

- ♦ Laminated, high carbon steel gears for longer life.
- ♦ Drive shaft gears are copper brazed for durability. All gears in models DL1300A thru DL3500B are heat treated.
- ♦ Rigid, welded reel construction for added strength.
- ♦ Winches freewheel when the ratchet is disengaged.
- ♦ Load matched gear ratios for easier cranking.
- ♦ Variety of finishes available – powder-coated copper bronze, black or zinc plated TUFFPLATE finish.
- ♦ All plated parts are zinc plated TUFFPLATE finish.
- ♦ Heavy duty steel handles with ergonomic molded grips. Quick-Attach handle is standard equipment on 2-speed models.
- ♦ Embossed, reinforced bases.
- ♦ All drive shafts have permanently lubricated bearings.
- ♦ 2-speed models have a drive shaft system which allows for both high and low speed cranking from one side.
- ♦ DL400, DL900A, DL1100A, DL1402A and DL2500A are available with 2" strap installed. Add the letter S after the model number for a strap, e.g. DL900AS.
- ♦ Full color trilingual (English / French / Spanish) laminated carton standard for models DL400 thru DL3200A.
- ♦ Individual winch straps available. (See page 6.)
- ♦ Cable clamp included on models DL1100A thru DL3500B. Cables sold separately. (See page 6.)
- ♦ Models DL400 thru DL3200A – Equipped with slots in reel for easy installation of optional strap. Strap not included on all models.
- ♦ DL400 has ratchet lever drive.
- ♦ Hand brakes are optional on DL1800A, DL2000A, DL2500A and DL3200A. Add the letter B after the model number for a hand brake, e.g. DL1800AB.
- ♦ Reel gear covers optional for DL1100A thru DL2500A models.
- ♦ Slotted mounting holes for easy installation.
- ♦ All models may be ordered with a large diameter reel hub. SAE Standard J1853 requires large hubs for steel cables. Add the letters LH after the model number for a large hub, e.g. DL2500ALH.



D-L pulling winches are not recommended for lifting applications. For lifting, use a D-L brake or worm gear winch. D-L winches are not to be used as hoists for lifting, supporting or transporting people, or for loads over areas where people could be present.

STANDARD DUTY



DL400



DL600A
DL900A



DL1100A
DL1300A

MEDIUM DUTY



DL1402A



DL1602ADD



DL1602A
DL1802A
DL2102A

HEAVY DUTY



DL1800A
DL2000A
DL2500A
DL3200A



DL3500B



Pulling Winch Specifications	Winch Series	Model	Rated Capacity (2)	Drum Hub Dia.	Gear Ratio	Handle Length	Max Mech. Adv.	Reversible Ratchet	2-Speed Operation	Maximum Drum Capacity	
										Cable (3)	Strap
	Standard Duty		DL400	400 lb/181 kg	5/8"	1:1	7"	18			1/8" x 87'
		DL600A	600 lb/272 kg	5/8"	3.2:1	7"	57			5/32" x 61'	16'
		DL900A	900 lb/408 kg	5/8"	3.2:1	7"	55			3/16" x 40'	16'
		DL1100A	1100 lb/499 kg	7/8"	3.7:1	7"	49			3/16" x 79'	29'
		DL1300A	1300 lb/590 kg	7/8"	4.4:1	7"	56			7/32" x 56'	31'
Medium Duty		DL1402A	1400 lb/635 kg	7/8"	4.4:1	9-1/2"	74	•		1/4" x 40'	31'
		DL1602A	1600 lb/726 kg	1-1/8"	5.4:1	9-1/2"	75	•		1/4" x 58'	45'
		DL1602ADD	1600 lb/726 kg	1-1/8"	5.4:1 / 1:1	9-1/2"	75	•	•	1/4" x 58'	45'
		DL1802A	1800 lb/817 kg	1-1/8"	5.4:1	9-1/2"	73	•		9/32" x 58'	38'
		DL2102A	2100 lb/952 kg	1-1/8"	5.4:1	11"	84	•		9/32" x 58'	38'
Heavy Duty		DL1800A	1800 lb/817 kg	1-1/8"	10.3:1 / 5.4:1	9-1/2"	139	•	•	9/32" x 58'	38'
		DL2000A	2000 lb/907 kg	1-1/8"	12.4:1 / 5.4:1	9-1/2"	168	•	•	9/32" x 58'	38'
		DL2500A	2500 lb/1134 kg	1-1/8"	17.3:1 / 5.4:1	9-1/2"	229	•	•	5/16" x 47'	38'
		DL3200A	3200 lb/1452 kg	1-1/8"	17.3:1 / 5.4:1	9-1/2"	219	•	•	3/8" x 30'	25'
		DL3500B (1)	3500 lb/1589 kg	1-5/16"	12:1 / 6:1	9-1/2"	135	•	•	3/8" x 37'	25'

(1) Hand brake standard equipment.

(2) Capacity based on direct line pull on the third layer of line on the drum. Capacity is reduced as the line builds up on the drum.

(3) Drum capacity based on cable size listed. (Cable not included.) Cable size listed may be too large to be practical for some applications.

NOTES:

Optional covers are available for some models.

Hand brake can be added to DL1800A, DL2000A, DL2500A, DL3200A.

Larger reel hubs are available for winches that will be used with cable.

HAND WINCH ACCESSORIES



Hand Winch Replacement Handles

6307 7" DL Handle. For DL500-1302 and WG series including 'A' models. Interchangeable with 6318.

6318 9-1/2" DL Handle. For DL1400 & 1402 including 'A' models. Interchangeable with 6307.

6319 9-1/2" DL Handle. For DL1602 & 1802 including 'A' models.

6322 9-1/2" DL Quick-Attach Handle. For DL1602DD and DL1700-3500B including 'A' models.

Above models individually packaged. 6/carton.

6450 7" DLB Handle. For DLB350-1200 including 'A' models. Interchangeable with 6451 and 6452.

6451 9-3/8" DLB Handle. For DLB1500-2500 including 'A' models. Interchangeable with 6450 and 6452.

6452 12" DLB Handle. Interchangeable with 6450 and 6451.

6455 12-1/4" 'B' Series Handle. For all 'B' Series Brake Winches.

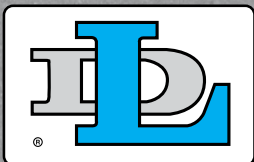

Hand Winch Strap and Hook

Model No.	Size	Capacity For winches up to	Breaking Strength
6148	2" x 15' / 50mm x 4.6m	1700lb / 771kg	2600lb / 1180kg
6149	2" x 20' / 50mm x 6.1m	1700lb / 771kg	2600lb / 1180kg
6248	2" x 15' / 50mm x 4.6m	2600lb / 1180kg	4000lb / 1814kg
6249	2" x 20' / 50mm x 6.1m	2600lb / 1180kg	4000lb / 1814kg
6250	2" x 25' / 50mm x 7.6m	2600lb / 1180kg	4000lb / 1814kg
6542	2" x 20' / 50mm x 6.1m	3200lb / 1453kg	4800lb / 2179kg
6551	2" x 15' / 50mm x 4.6m	3700lb / 1678kg	6600lb / 2996kg
6552	2" x 20' / 50mm x 6.1m	3700lb / 1678kg	6600lb / 2996kg
6553	2" x 25' / 50mm x 7.6m	3700lb / 1678kg	6600lb / 2996kg

Includes mounting hardware.



6147 PWC Trailer Strap & Hook

Designed for PWC trailer application. 12' strap w/hook includes 1" x 18" loop. Designed for winches up to 900 lb. Packed with 1/4" x 2-1/2" mounting bolt and locknut.

Winch Cable/Hook Assembly

Model	Size
6210	3/16" x 25'
6211	3/16" x 50'
6212	7/32" x 50'
6360	3/16" x 20'
6361	7/32" x 25'
6520	1/4" x 25'
6522	5/16" x 25'
6524	1/4" x 50'



Flexible high strength 7 x 19 galvanized aircraft cable.



Caution: Safe working loads for cables vary widely, depending on conditions of use. Recommended safe working loads for all applications other than those listed below are: 3/16" - 840 lbs. 7/32" - 1120 lbs. 1/4" - 1400 lbs. 5/16" - 1960 lbs.

3/16" cables are suitable for use on D-L hand winches up to 1800 lb capacity and electric winch models SA5000 and SA7000. 7/32" cables are suitable for use on D-L hand winches up to 2500 lb capacity and electric winch models SA9000 and SA12000. 1/4" or 5/16" cables are suitable for D-L hand winches up to 3500 lb. capacity.

6285 Cable Clamp

For all D-L pulling and brake winches.



6565 Winch Mounting Bracket

Universal right angle mounting bracket fits most hand winches up to 2000 lb capacity. Heavy 1/4" steel with tough powder coated finish.



Ratchet Repair Kits

For D-L pulling winches.

Kit #	For Winch Model					
6290	DL500	DL600	DL800	DL900	DL1000	DL1300
6290A	DL600A	DL900A	DL1100A	DL1300A		
6291	DL1200	DL1302	DL1400	DL1402		
6291A	DL1402A	DL1602A	DL1602ADD			
6292	DL1602	DL1602DD				
6293	DL1700	DL1800	DL1802	DL2000	DL2500	DL3000
6294A	DL1800A	DL1802A	DL2000A	DL2102A	DL2500A	DL3200A



Ratcheting Handle

When used in place of regular handle, ratcheting action allows for better leverage. 6323 and 6327 handles are also ideal for applications where cranking space is limited.

6323 fits B series.

6327 fits DLB series.

6459 fits DL1602A and DL1802A.



Cable Fastener - Threaded

For most pulling, brake and worm gear type winches.

6357 3/8" fits DL600A and DL900A models. For 3/16" cable.

6358 7/16" fits DL1100A thru DL1402A, B1200B and DLB800A models. For 3/16", 7/32", and 1/4" cable.

6359 1/2" fits DL1602A thru DL2500A, B1500 thru B2500, DLB1200A thru DLB2500A and all WG models. For 1/4", 9/32", and 5/16" cable.



BRAKE WINCHES

D-L brake winches are suitable for many lifting and lowering applications. Self-locking brake winches provide additional safety and control for many lifting and pulling jobs. The automatic friction brake supplies constant, positive holding action and prevents a runaway load. Brake is fully automatic and the load remains in position any time the handle is released. A load is required to pull line from the winch drum.



All D-L brake winches are built for multipurpose hauling and lifting operations. They are not to be used as hoists for lifting, supporting or transporting people, or for loads over areas where people could be present.

Brake Winch Features

- ♦ Laminated high carbon steel gears are heat treated for longer life.
- ♦ Embossed, reinforced bases for extra strength.
- ♦ Meets ASAE Safety Standard S361.3.
- ♦ Handle is integral part of braking mechanism.
- ♦ Cable clamp standard. Cable not included.
- ♦ Ratcheting handle for limited cranking space is available.
- ♦ DLB series available in powder coated copper bronze or zinc plated TUFFPLATE finish.

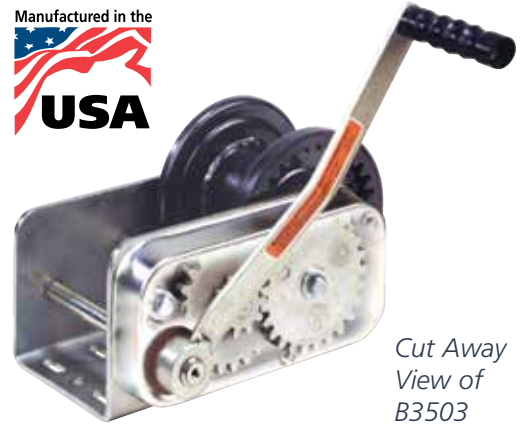

Cut Away View of B3503

CHAIN DRIVE WINCHES

- ♦ For boat lifts
- ♦ Enclosed design
- ♦ Aluminum housing
- ♦ Utilizes sprockets and roller chain
- ♦ Built-in brake mechanism
- ♦ Stainless steel fasteners
- ♦ Steel-backed PTFE lined bearings
- ♦ Removable access panel and top cover makes it easy to change brake pads if needed 
- ♦ Mounting holes identical on both sides

NEW



CD3500



CD4500



CD5500



Top view, with cover off

Chain Drive Brake Winch Specifications

Model	Single Line Load Capacity*	Double Line Load Capacity*	Drum Hub Dia.	Gear Ratio	Dimensions (H x W x D)	Weight
CD3500	1750 lb/793 kg	3500 lb/1587 kg	2"	11.5:1	13-9/16" x 10" x 4-1/4"	23.5 lb
CD4500	2250 lb/1020 kg	4500 lb/2041 kg	4"	25.1:1	13-1/4" x 10-1/4" x 5-1/2"	29.5 lb
CD5500	2750 lb/1247 kg	5500 lb/2494 kg	4"	24.4:1	15-1/4" x 10-1/4" x 5-1/2"	33 lb

*Capacity based on direct line pull on first layer of line on drum. Capacity is reduced as line builds up on drum.

DLB SERIES BRAKE WINCHES

DLB models have brake winch safety and rugged construction at an economical price.

DLB series available in powder coated copper bronze or zinc plated **TUFFPLATE** finish.



DLB350A



DLB800A



DLB1200A



DLB1500A



DLB2500A



DLB Series Brake Winch Specs

Model	Rated Capacity (1)	Min. Operating Load Required	Drum Hub Dia.	Gear Ratio	Handle Length	Maximum Mechanical Advantage	Maximum Drum Capacity	
							Cable (2)	Strap
DLB350A	350 lb/159 kg	50 lb/23 kg	1"	3.2:1	7"	39.8	1/8" x 84'	15'
DLB800A DLB805A	800 lb/363 kg	50 lb/23 kg	1-7/8"	4.4:1	7"	29.9	3/16" x 68'	27'
DLB1200A DLB1205A	1200 lb/545 kg	50 lb/23 kg	2-1/2"	5.4:1	7" Std. 9-3/8" Opt.	27.8 37.2	7/32" x 69'	31'
DLB1500A DLB1505A	1500 lb/681 kg	75 lb/34 kg	2-1/2"	5.4:1	9-3/8" Std. 12" Opt.	36.8 47.1	1/4" x 60'	31'
DLB2500A DLB2505A	2500 lb/1134 kg	175 lb/80 kg	2-1/2"	17.3:1	9-3/8" 12" Opt.	115.3 147.6	5/16" x 34'	21'

(1) Capacity based on direct line pull on first layer of line on drum. Capacity is reduced as line builds up on drum.

(2) Drum capacity shown is based on cable size listed. (Cable not included.) Cable size listed may be too large to be practical for some applications.



All D-L brake winches are built for multipurpose hauling and lifting operations. They are not to be used as hoists for lifting, supporting or transporting people, or for loads over areas where people could be present.

Freewheeling Feature

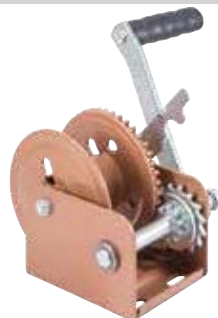

DLB805A



DLB1205A

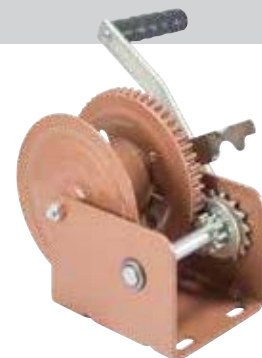

DLB1505A

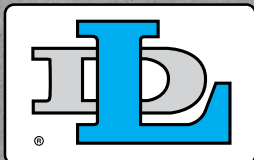

B SERIES BRAKE WINCHES

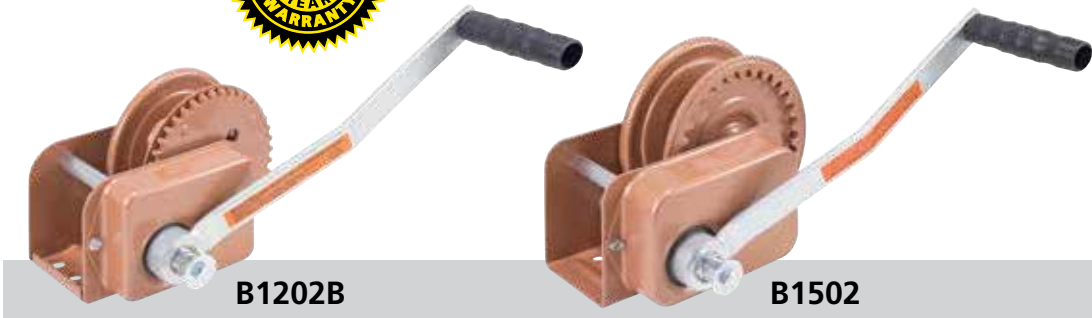

B1202B

B1502



B2503

B3503

B Series Features

- ♦ Extra heavy construction for long life.
- ♦ Gear cover enclosed braking mechanism.
- ♦ B series (except B1200) has drive shaft needle bearings.
- ♦ Available in powder coated copper bronze (except B4010A and B3503) or zinc plated TUFFPLATE finish with powder coated black reel.



All D-L brake winches are built for multipurpose hauling and lifting operations. They are not to be used as hoists for lifting, supporting or transporting people, or for loads over areas where people could be present.

B Series Brake Winch Specifications

Model	Rated Capacity	Min. Operating Load Required	Drum Hub Dia.	Gear Ratio	Handle Length	Max. Mech Advantage	Maximum Drum Capacity (3) Cable
B1200B	1200 lb/545 kg (1)	75 lb/34 kg	1-1/8"	4:1	12-1/4"	72.9	7/32" x 57'
B1202B	1200 lb/545 kg (2)	75 lb/34 kg	2-1/2"	4:1	12-1/4"	36.0	7/32" x 46'
B1500	1500 lb/681 kg (1)	150 lb/68 kg	1-1/8"	6:1	12-1/4"	106.9	1/4" x 52'
B1502	1500 lb/681 kg (2)	150 lb/68 kg	2-1/2"	6:1	12-1/4"	53.5	1/4" x 45'
B2500	2500 lb/1135 kg (1)	300 lb/136 kg	1-5/16"	12:1	12-1/4"	180.9	5/16" x 51'
B2502	2500 lb/1135 kg (2)	300 lb/136 kg	2-1/2"	12:1	12-1/4"	104.5	5/16" x 45'
B2503	2500 lb/1135 kg (2)	300 lb/136 kg	3-1/8"	12:1	12-1/4"	85.5	5/16" x 40'
B3503	3500 lb/1589 kg (2)	500 lb/227 kg	3-1/8"	18.75:1	12-1/4"	131.3	3/8" x 28'
B4010A	4000 lb/1814 kg (2) (4)	--	2-1/2"	41:1	--	--	9/32" x 54' (27' per side)

(1) Capacity based on direct line pull on third layer of line on drum. Capacity is reduced as line builds up on drum.

(2) Capacity based on direct line pull on first layer of line on drum. Capacity is reduced as line builds up on drum.

(3) Drum capacity shown is based on cable size listed. **(Cable not included.)** B series winches are not strap adaptable. Cable size listed may be too large to be practical for some applications.

(4) 4000 lb. capacity based on using 2 cables in opposite directions with equal load of 2000 lb on each cable.



B4010A

Designed for ceiling mount applications. 4000 lb rated capacity loop drive brake winch with split reel. Allows for pulling of 2 cables in opposite directions. Zinc plated TUFFPLATE finish.

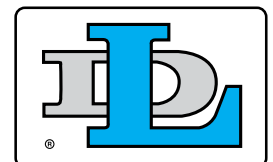

WORM GEAR WINCHES

Applications requiring safe, controlled movement of loads need D-L worm gear winches. The reel automatically stops turning whenever cranking is stopped. There is no freewheel mode, no special mechanism required to stop gear movement and they do not require a minimum load for operation.



WG1500HEX



WG1500SR

POWDER COATED TOUGH



Worm Gear Features

- ♦ Laminated high carbon steel gears are heat treated for longer life.
- ♦ Heavy gauge embossed steel bases for extra strength.
- ♦ Permanently lubricated bearings on drive shaft are maintenance-free.
- ♦ Available in regular or split reel, which allows for operation of 2 lines for greater versatility. **Also available with 5/8" hex drive for operation with electric drill or removable handle.**
- ♦ Choose from handle or loop drive models.
- ♦ Loop drive allows the winch to be mounted out of reach and operated with an extension pole fitted to engage the loop.
- ♦ Standard finish is powder coated copper bronze.



All D-L worm gear winches are built for multipurpose hauling and lifting operations. They are not to be used as hoists for lifting, supporting or transporting people, or for loads over areas where people could be present.

Worm Gear Specs	Model	Winch Description	Rated Capacity (1)	Drum Hub Dia.	Gear Ratio	Handle Length	Max. Mech Adv.	Maximum Drum Capacity (2)
	WG1500	Regular Drum Handle Drive	1500 lb/681 kg	1.5"	30:1	7"	240	1/4" x 43'
	WG1500LD	Regular Drum Loop Drive	1500 lb/681 kg	1.5"	30:1	—	—	1/4" x 43'
	WG1500SR	Split Reel Handle Drive	1500 lb/681 kg	1.5"	30:1	7"	240	1/4" x 43' 21.5' per side
	WG1500SRLD	Split Reel Loop Drive	1500 lb/681 kg	1.5"	30:1	—	—	1/4" x 43' 21.5' per side
	WG1500HEX	Regular Drum Handle Drive	1500 lb/681 kg	1.5"	30:1	—	—	1/4" x 43' 21.5' per side
	WG2000	Regular Drum Handle Drive	2000 lb/908 kg	1.5"	40:1	7"	314	9/32" x 49'
	WG2000LD	Regular Drum Loop Drive	2000 lb/908 kg	1.5"	40:1	—	—	9/32" x 49'
	WG2000SR	Split Reel Handle Drive	2000 lb/908 kg	1.5"	40:1	7"	314	9/32" x 49' 24.5' per side
	WG2000SRLD	Split Reel Loop Drive	2000 lb/908 kg	1.5"	40:1	—	—	9/32" x 49' 24.5' per side
WG2000HEX	Regular Drum Handle Drive	2000 lb/908 kg	1.5"	40:1	—	—	9/32" x 49' 24.5' per side	

(1) Capacity is based on direct line pull on the first layer of line on the drum. Capacity is reduced as line builds up on the drum.

(2) Drum capacity shown is based on cable size listed. (Cable not included.) Cable size listed may be too large to be practical for some applications.



Manufactured in the

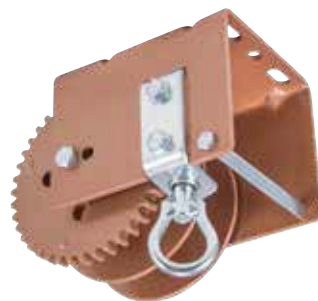

WG2000SRLD

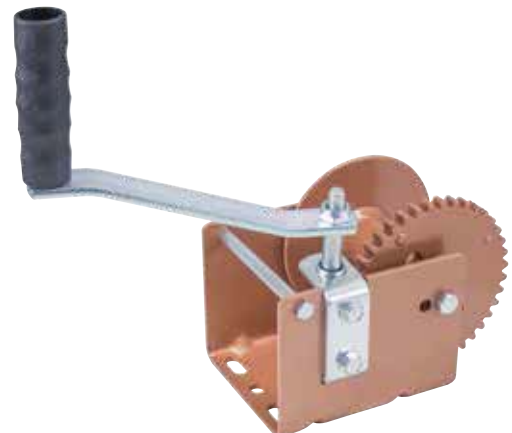

WG2000

ELECTRIC WINCHES



Dutton-Lainson Company's versatile StrongArm electric winches provide load-moving muscle with just the push of a button or switch. With rated load capacities up to 4500 lb (dead-weight) **double line operation**, these winches will save manpower and make quick work of difficult loading and pulling jobs. All StrongArm electric winches, except the TW4000, offer Power-in, Power-out, controlled Freewheel and automatic braking. Accessories allow for easy mounting on trailers, vehicle hitch balls and other machinery and equipment. Remote control kits are also available.

For vertical lifting applications, we recommend ordering a winch with no clutch installed. Call factory to specify.



Electric Winch Ratings

Electric winches are designed for intermittent use only. These ratings are based on a 10 ft. pull for SA Series and a 6 ft. pull for TW Series. For longer pulls at full capacity, occasional motor cooling periods should be allowed. For rolling load capacity, see page 26.

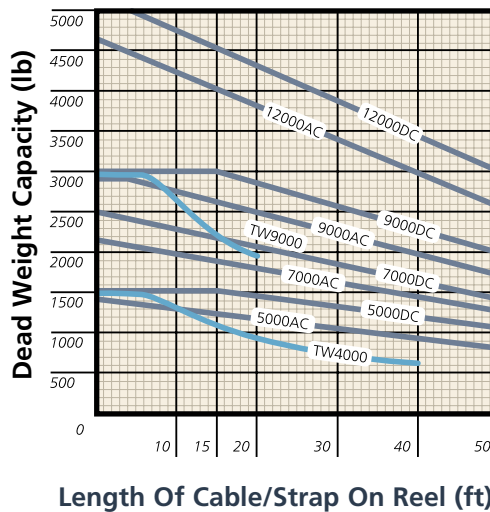

SA & TW Series Features

- ♦ Electric winch gear-train uses heat-treated sintered-iron gears for smooth, quiet operation.
- ♦ Final drive gears are heat-treated high carbon steel for greater strength.
- ♦ Precision needle bearings are used in high-load areas for low friction and longer life.
- ♦ Die formed base is adapted for quick mounting applications.
- ♦ Hook safety snap keeps load securely attached.
- ♦ High impact weather resistant case provides excellent protection for internal components.
- ♦ Attractive brushed stainless steel front plate for superior rust resistance.

Winch Controls

Electric switch and clutch controls are both located on the same side for easy operation. Electric switch automatically returns to the "OFF" position when released. **Clutch control** provides for smooth load control from a locked to a free-wheel position. It automatically returns to a locked position when released (except on the TW4000). If desired, clutch can be used for a controlled load release without electric power. Clutch can also be locked in the freewheel position for easy cable removal.

SA Remote Control Models



- ♦ Both AC & DC models available with built-in remote control.
- ♦ Hand-held switch pendant with 10' cord.
- ♦ AC models with 6349 remote include dynamic brake feature.

All SA Remote Control Models have model numbers ending in 15. See Chart on Page 12

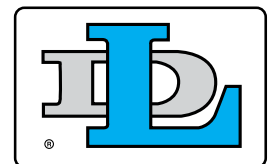

StrongArm® ELECTRIC WINCHES



- ◆ Features Power-in, Power-out, controlled Freewheeling clutch and automatic brake.
- ◆ Available in 120 volt AC and 12 volt DC models.
- ◆ SA models equipped with flexible high strength 7 x 19 galvanized aircraft cable (except SA9010AC). All SA models will also accept 2" wide strap.
- ◆ Emergency crank handle is standard equipment.



SA12000AC



SA9000DC

AC Models

- ◆ 120 volt AC operation complete with 10 foot, 3 wire grounded power cord and built-in 3 position rocker switch.
- ◆ Available with CSA NRTL/C approval, signifying the winch has been evaluated to applicable ANSI/UL and CSA standards for use in the U.S. & Canada. NRTL (Nationally Recognized Testing Laboratory) is designation granted by OSHA to laboratories which have been recognized to perform certification to U.S. standards.
- ◆ 6349 Dual Switch Remote Control with dynamic brake feature is available factory installed (see chart below) or separately (see page 14).
- ◆ Model SA9010AC is designed for davit applications in and near salt water environment. It includes SA9000AC less clutch (eliminates freewheeling) and cable. Power-in and Power-out only with stainless steel reel. Also includes GFCI breaker and 6349 dynamic brake remote.

DC Models

- ◆ High-torque 12 volt DC motor has circuit-breaker overload protection.
- ◆ StrongArm DC electric winches have a dynamic motor brake as well as a mechanical friction brake to more securely hold the load.
- ◆ DC models include wiring harness (25 foot positive battery wire and 8 foot ground wire).
- ◆ Remote control available built-in (see chart below) or as a kit (see page 14).

SA Winch Specifications	Model (1)	Volts / Amps	Load Capacity (3)	Gear Ratio	Cable	Pulley Block & Hook	Approximate Load Speed (ft./min.)			
							No Load		Full Load	
							Full Reel	Empty Reel	Full Reel	Empty Reel
	SA5000 & SA5015	12 Volt DC / 70	1500 lb/681 kg	189:1	3/16" x 20' (6360)					
	SA5000AC & SA5015AC	120 Volt AC / 7	1200 lb/545 kg	189:1	3/16" x 20' (6360)					
	SA7000 & SA7015	12 Volt DC / 70	2200 lb/999 kg (2)	189:1	3/16" x 50' (6211)	•				
	SA7000AC & SA7015AC	120 Volt AC / 7	1800 lb/817 kg (2)	189:1	3/16" x 50' (6211)	•				
	SA9000 & SA9015	12 Volt DC / 70	3000 lb/1362 kg	570:1	7/32" x 25' (6361)					
	SA9005	Same as SA9000 except less clutch with Remote Kit #6383 (4)								
	SA9000AC & SA9015AC	120 Volt AC / 7	2700 lb/1226 kg	570:1	7/32" x 25' (6361)					
	SA9010AC	Same as SA9000AC except less clutch and cable with stainless steel reel & GFCI in 10' cord and 6349 Dynamic Brake								
	SA12000 & SA12015	12 Volt DC / 70	4500 lb/2043 kg (2)	570:1	7/32" x 50' (6212)	•				
	SA12000AC & SA12015AC	120 Volt AC / 7	4000 lb/1816 kg (2)	570:1	7/32" x 50' (6212)	•				

(1) Model numbers with 15 have built-in remote control (AC models use 6349 remote). (2) Double line operation. (3) For a full reel of line, adjust capacity according to graph on page 11. (4) See page 14.



All D-L StrongArm electric winches are built for multipurpose hauling and pulling operations. They are not to be used as hoists for lifting, supporting, or transporting people, or for handling loads over areas where people could be present.



TW ELECTRIC WINCHES

- ◆ Electric winches for boat trailer and other horizontal pulling applications.
- ◆ Built to the same high quality standards as the SA series.
- ◆ Wiring harness (25 foot positive battery wire and 8 foot ground wire) included.
- ◆ Equipped with 20' x 2" polyester strap and hook.
- ◆ Both TW models available with built-in remote control (hand-held switch pendant with 10' cord).



TW4000

TW4000

- ◆ Designed for boats up to 4000 lb.
- ◆ Features Power-in and Freewheel-out operation with positive mechanical brake.
- ◆ Clutch control knob engages gears or releases load in a controlled Freewheel mode.

TW9000

- ◆ For boats up to 9000 lb.
- ◆ Offers Power-in, Power-out and Freewheel operation with dynamic brake and mechanical friction brake.
- ◆ 3 position rotary switch.
- ◆ Includes emergency crank handle.
- ◆ Same clutch control feature as the SA series.



TW9000

TW Winch Specifications								
Model Number	Volts / Amps	Load Capacity*	Gear Ratio	Strap	Approximate Load Speed (ft./min.)			
					No Load		Full Load	
					Full Reel	Empty Reel	Full Reel	Empty Reel
TW4000	12 Volt DC / 40	1500 lb/681 kg	324:1	2" x 20' (6149)	22	11	8.2	4.4
TW4015	12 Volt DC / 40	1500 lb/681 kg	324:1	2" x 20' (6149)	22	11	8.2	4.4
TW9000	12 Volt DC / 70	3000 lb/1362 kg	570:1	2" x 20' (6542)	15	9	6.3	4.3
TW9015	12 Volt DC / 70	3000 lb/1362 kg	570:1	2" x 20' (6542)	15	9	6.3	4.3

*For a full reel of line, adjust capacity according to graph on page 11.



All D-L StrongArm electric winches are built for multipurpose hauling and pulling operations. They are not to be used as hoists for lifting, supporting, or transporting people, or for handling loads over areas where people could be present.



StrongArm® ACCESSORIES



6364 StrongArm Crank Handle

Zinc plated TUFFPLATE finish. Fits SA models and TW9000. Features spring loaded safety clip.



6363 Winch Cover

Keeps all StrongArm and TW series winches clean, dry and looking like new. Strong vinyl.



6365 Quick Mount Kit

Provides quick, easy winch installation and removal. Includes 3 shoulder studs and nuts, plus 3/8" bolt, lock washer and wing nut.

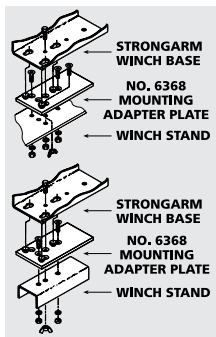

6368 Adapter Plate

Heavy 3/8" x 4" x 8" plated steel plate with quick mount studs, properly mounts winch on narrow stands.



6370 GFCI Breaker

For 120 volt AC StrongArm winch models or other applications. Rated 15 amp, 125 volt, 3 conductor 14 gauge wire, 10' length. Breaker mounted 7-1/2" from plug. Water resistant.



6367 In-Cab Switch Receptacle

For 12 volt DC StrongArm SA winch models. Mounts under dashboard for winch operation from inside cab. Includes switch bracket and 10' of wire. Plugs directly into winch switch pocket without rewiring.



Electrical Quick Connect

6385 For all 12 volt DC SA models and TW9000.

6288 For TW4000.



6366 Ball Adapter Plate

Makes StrongArm SA Series winch available for instant mount operation. Bolt plate to winch, slip pear-shaped cutout over any standard front or rear mounted hitch ball up to 2". Zinc plated TUFFPLATE finish.



6349 Dynamic Brake Remote Control

Fits all 120 volt AC StrongArm electric winch models. Dual switch controls, in/out and off/run. Provides dynamic braking function. Dynamic brake supplements mechanical brake to bring a load to a quick halt without coasting.



6371 Remote Hand-Held Switch

For 12 volt DC StrongArm SA winch models. Permits user to operate winch from location up to 10 feet away. Control box mounts on or next to winch and plugs directly into winch switch pocket without rewiring. Durable hand-held pendant switch can be unplugged for safe storage.



Wiring Harness

6362 fits 12 volt DC SA models except those ending in 15. 25' power cable, 8' ground cable, #8 wire with switch and 70 amp circuit breaker.

6575 fits TW4000 for model year 2013 and before. 25' power cable, 8' ground cable. #12 wire with 35 amp circuit breaker.

6578 fits TW4000 for model year 2014 to present.

6576 fits TW9000 and SA models ending in 15. 25' power cable, 8' ground cable. #8 wire with 70 amp circuit breaker.



6372 Remote Hand-Held Switch

For 120 volt AC StrongArm winch models. Provides 10' remote hand-held switch unit for wiring directly to winch. Pendant has an "In-Off-Out" switch similar to power switch provided on all 120 volt AC StrongArm winch models.



6373 Plug-in Connector

Accessory for 6371, 6372 and 6349 Remote Switch Kits.



6383 In-Cab Remote Switch Kit

For 12 volt DC StrongArm SA winch models. Includes heavy-duty 3-position rotary switch, 80 amp circuit breaker, 15' (+) and 5' (-) battery wires and two 10' switch-to-winch wires. Switch can be mounted in vehicle dashboard for easy access. Plugs directly into winch switch pocket without rewiring.

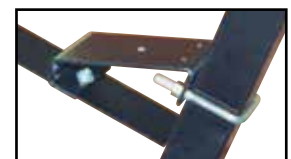

6370 Angle Mounting Plate

For mounting all StrongArm electric winches to trailer winch stands where insufficient room and improper angle are present.

TRAILER ACCESSORIES



6000

Coiled Safety Cable Sets

5/16" vinyl coated cables with safety hooks. For use on trailers up to 6500 lbs. Coil tension eliminates dragging and rattles. Cables extend to 40". Meets SAE and V-5 standards. Sold in pairs.

Chains & Cables	Model	SAE Class	Length & Type	Cable or Chain Link Size
	6217	1	Two 24" Chains	3/16"
	6255	1	Two 18" Chains	3/16"
	6227	2	Two 36" Chains	5/0
	6254	3	Two 36" Chains	1/4"
6000	4 (6500 lb)	Two 40" Cables	5/16" coated	



Safety Chains

All D-L safety chains are welded link construction with a bright zinc plated finish. Each chain includes a heavy steel hook with **safety clip**. Meets SAE and V-5 standards. 2/package.



6121

Trailer Spare Tire Carrier

Extends spare tire up and away from trailer and boat. Heavy-duty steel construction. Fits wheel sizes from 9" to 14", 4 or 5 hole rims and trailer tongues up to 3" x 5". Complete with mounting hardware. Available with durable black powder-coated painted finish or zinc plated TUFFPLATE finish. Specify painted or plated when ordering.

6122

Similar to 6121, but fits aluminum I-beam trailers. Three sizes – 4-1/2", 5-1/2" and 6-1/2".

Spare Tire Carriers



6220

Extra length allows handling of wide tires or spans the wider tongues of custom built trailers. Fits 4 or 5 hole rims. Zinc plated finish.

6281

Spare tire carrier with bracket (padlock not included).



6280

Spare tire carrier with lock, adds extra protection.



6126 Extra Offset Spare Tire Carrier

This heavy duty carrier extends the spare tire at an angle to avoid damage or marring of boat finish. Zinc plated TUFFPLATE finish. Fits wheel sizes from 13" to 15", 5 or 6 hole rims and trailer tongues 2" to 3" wide, and 3" to 5" tall.

6259 Tipperlatch

For use on tilt-bed medium & light duty trailers such as PWC, snowmobile & utility. Automatic latch holds tilt bed in place. Spring loaded non-pinching latch for easy release. Zinc plated TUFFPLATE finish.



ACCESSORIES

Pulley Blocks

Pulley blocks for double line operation on electric winches. Feature bronze bushings.

6209

Standard



6213

With hook



6216

With swivel hook



6239

Snap Hook

Forged steel hook with safety latch. Tensile strength 7500 lb.



6750

Toggle Clamp

With cam action. For tie downs and hold downs. Zinc plated TUFFPLATE finish.



D-L Pulley Blocks are suitable for use with StrongArm Electric Winches. Recommended safe working load for all other applications is 1500 lb.



6230 Bow Hold Down

Snap lock, spring tension, adjustable to maximum 32" length. Wide hook fits most bow eyes. Zinc plated. Furnished with 2" eye bolt.



6231 Transom Hold Down

For inboards and inboard outdrives. Snap lock, spring tension, adjustable to maximum 32" length. Wide hook permits use with ski rings in transom. Zinc plated. Furnished with "S" hook for mounting. Sold in pairs.

COUPLERS



A key element of easy hitching, unhitching and safe trailer towing is a strong and efficiently operating coupler system, properly installed on the tongue of the trailer. D-L couplers (except 998-4) offer an exclusive Quick-Lock ball clamp assembly that can be adjusted without wrenches. This feature provides a precise fit on the hitch ball while the trigger action release allows fast locking and unlocking. The lock lever is held securely closed by cam action and the safety latch. Model 998-4 uses heavy-duty welded construction.

Manufactured in the



Coupler Features

- ◆ D-L couplers, coupler balls and trailer safety chains meet all requirements of SAE J684 and VESC V-5 standards, for class 1, 2, 3 and 4.
- ◆ Two 50 mm models comply with 94/20/EEC Standards for use in the European Community.
- ◆ Couplers are easily and quickly unlocked by a trigger action release on safety lever.
- ◆ Safety pin can be inserted through a hole in lever to provide a secondary means of securing ball clamp in a locked position.
- ◆ A-frame couplers are designed to be mounted on frame members set at 50°.
- ◆ A padlock may be substituted for pin if security against trailer theft is desired.



U.S. Patent
#6,481,740 B1

980P-2
981P-2
982P-2



Shown:
Retail Pack

Label on coupler housing provides consumer information and UPC. **940-1**
960-1
Pin & chain not included. **970-1**

985P-3



990-3 Standard
990-3N Without Jack Hole

Coupler Specs	Model	SAE Class	Ball Size	Housing Width (Inside)	Clam Shell Units Per Carton	Retail Pack Per Carton	SAE Class Specs For Non-Passenger Carrying Trailers
	940-1	1	1-7/8"	2"	6	15	SAE CLASS 1 For gross trailer weights up to 2000 lb / 908 kg
	960-1	1	1-7/8"	2-1/2"	6	15	
	970-1	1	1-7/8"	3"	6	15	
	980-2	2	2"	3"	6	10	SAE CLASS 2 For gross trailer weights up to 3500 lb / 1589 kg
	981-2	2	2"	2"	6	10	
	982-2	2	2"	2-1/2"	6	10	
	985-3	3	2"	3"	6	10	SAE CLASS 3 For gross trailer weights up to 5000 lb / 2270 kg
	995P-4	4 (6000 lb)	2"	3"	—	—	
	990-3	3	2"	A-Frame	—	6	SAE CLASS 4 For gross trailer weights between 5000 lb / 2270 kg and 10,000 lb / 4540 kg
998-4	4 (10000 lb)	2-5/16"	A-Frame	—	—		



998-4 (Imported)

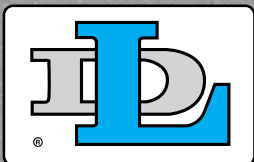

COUPLER BALLS AND ACCESSORIES

Coupler Balls

For a perfect fit to D-L couplers. Model 6692 is stainless steel finish; all other models are chrome.



Coupler Ball Specs	Model	SAE Class	Capacity (lb)	Ball Size	Shank Diameter	Shank Length	Min. - Max. Mounting Thickness
	6391	3	5000	2"	1"	2"	1/4" - 1"
	6393	4	6000	2-5/16"	1"	2"	5/16" - 15/16"
	6396	1	2000	1-7/8"	3/4"	1-1/2"	3/8" - 1"
	6397	2	3500	2"	3/4"	1-1/2"	3/8" - 7/8"
	6692	3	5000	2"	1"	2"	1/4" - 1"
	6693	1 & 2	2000/3500	1-7/8" & 2"	3/4"*	1-7/8*	3/4" - 1"
	*Also includes adapter to fit 1" hole.						

6295 Coupler Grip



Bolts onto coupler with universal mounting holes. Fits 1-7/8" and 2" couplers. Coupler grip provides convenient and safer way to guide trailer tongue to and from coupler ball. Ideal for personal watercraft and other lightweight trailers. Zinc plated TUFFPLATE finish with large comfortable grip.

6279 BUMP-ME® Coupler-Vehicle Cushion



Absorbs blow between coupler and towing vehicle when hook-up is misjudged. Slips onto the coupler flange. No tools required. Molded with U.V. inhibitor, resists deterioration and stays flexible in all kinds of weather. Fits most brands of Class 1 - 4 couplers.

6298 HITCH-LOCK® Trailer Guard



Protects both attached and unattached trailers. Design shields padlock from bolt cutters and hacksaws. Zinc plated TUFFPLATE finish.

Model	SAE Class	Ball Size
6256	1	1-7/8"
6257	2 & 3	2"
995	4	2"

Coupler Repair Kits

D-L coupler repair kits allow for easy replacement of entire ball clamp assembly if original becomes damaged or worn. For D-L Quick-Lock couplers only. Kits cannot be interchanged with component parts of any other D-L models or other manufacturers' couplers.





TONGUE JACKS



When hitching and unhitching loaded trailers, D-L tongue jacks are real back savers. These easy-to-install smooth operating tongue jacks can be mounted in a variety of ways on various sizes of trailer tongues. Heavy-duty D-L tongue jacks reduce the physical effort required to maneuver a loaded trailer into hitching position or removing the trailer from a vehicle. All models are made from heavy gauge steel for strength and durability.

- ◆ Enclosed outer tube helps protect miter gears and heavy duty Acme screw from sand and dirt.
- ◆ Fits square tongues up to 3" x 5". All mounting hardware included.
- ◆ 2-1/2" diameter mounting hole in swivel bracket fits most other brands of mounting hardware.
- ◆ Floating miter gears allow for proper clearance and easier operation.
- ◆ **Many models are also available with an independent wheel assembly for maximum maneuverability.**
- ◆ Zinc plated TUFFPLATE finish for longer life.
- ◆ Tough polypropylene wheels or zinc plated foot.
- ◆ Ergonomic hand grip with textured surface.



Manufactured in the



USA

Swivel Mount



6460

Top wind
1000 lb
capacity



6400

1000 lb
capacity

12" travel.
Bracket located
higher for use
with higher
hitch balls.



6709

1000 lb
capacity

12" travel.
Dual 6" wheels
for added
stability.



6800

1500 lb
capacity

Swivel Jacks offer easy-to-use features:



- ◆ Minimum cranking when disconnecting from towing vehicle.
- ◆ Easily rotated to vertical operating position. 
- ◆ Locking mechanism is spring loaded.

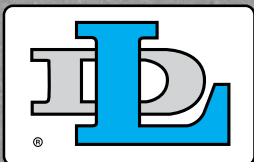

Swivel Mount

Swivel Jack with 8" Wheel

6850 - Heavy-duty 8" wheel maneuvers easily over rough terrain. Reinforced wheel bracket for extra rigidity. 1500 lb. capacity and 10" travel. Four-bolt swivel mounting system for greater strength.

6851 - Same as 6850, but with independent wheel.+ 



Pivoting Stand With Wheel or Foot

6724 - 600 lb capacity with Wheel

6726 - 1000 lb capacity with Foot

Inexpensive support for lightweight trailers or trailers in long-term storage.



Top Wind Jack With Independent Wheel

6461 - 1000 lb capacity, top wind, with independent wheel. Top wind handle for applications where clearance is an issue. Independent wheel turns more easily, particularly in sand or gravel.+



+Grooved inner post and nylon bearings allow smoother rotation.

Swivel Jack Specs	Model	Capacity	Mounting*	Handle Type	Wheel	Travel	Maximum Tongue Height	Swivel Pin Dia.
	3400	1200 lb/545 kg	Bolt-on	Side	6"	11"	25"	1/2"
	6400	1000 lb/454 kg	Bolt-on	Side	6"	10"	25"	3/8"
	6430	1000 lb/454 kg	Bolt-on	Side	8"	10"	25"	1/2"
	6440	1000 lb/454 kg	Weld-on	Side	6"	10"	25"	1/2"
	6445	1000 lb/454 kg	Weld-on	Side	6"	10"	25"	1/2"
	6460	1000 lb/454 kg	Bolt-on	Top	6"	10"	26"	3/8"
	6461	1000 lb/454 kg	Bolt-on	Top	6"	10"	26"	3/8"
	6709	1000 lb/454 kg	Bolt-on	Side	6"	12"	29"	3/8"
	6724	600 lb/272 kg	Bolt-on	N/A	6"	N/A	14-1/2"	3/8"
	6726	1000 lb/454 kg	Bolt-on	N/A	Foot	N/A	14-1/2"	3/8"
6800	1500 lb/680 kg	Bolt-on	Side	6" Dual	12"	28-1/2"	1/2"	
6850	1500 lb/680 kg	Bolt-on	Side	8"	10"	24-3/4"	1/2"	
6851	1500 lb/680 kg	Bolt-on	Side	8"	10"	24-3/4"	1/2"	

*All bolt-on jacks above fit tongues up to 3" x 5".

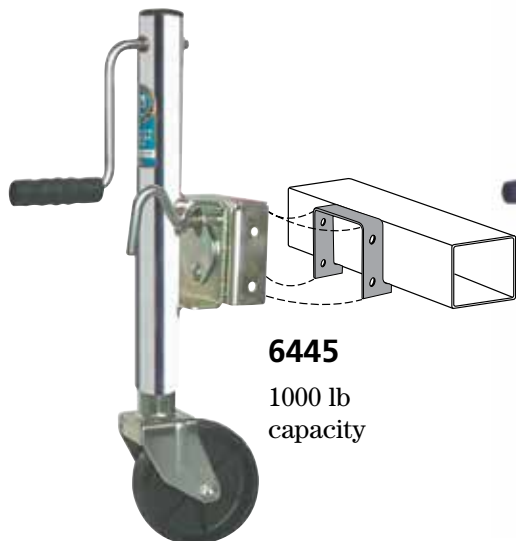

6445
1000 lb capacity

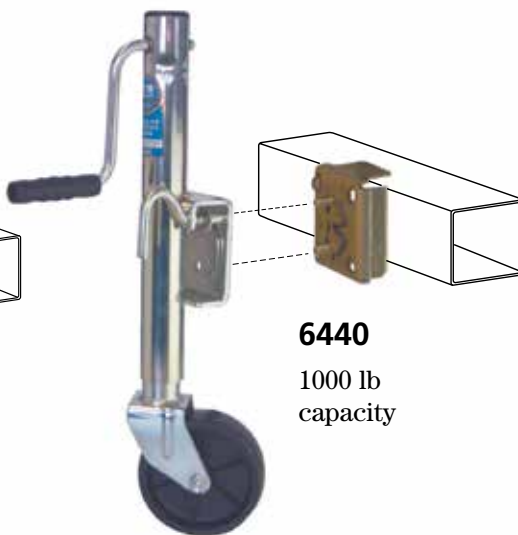

6440
1000 lb capacity

3400 (Imported)

1200 lb capacity. Tested to D-L standards. Available boxed or bulk.



TONGUE JACKS

Rigid Mount



6414
1000 lb capacity



6814
1250 lb capacity



6817
1250 lb capacity with independent wheel



6820 Drop Leg
2000 lb capacity

Rack-Type



6740
800 lb capacity

Worm gear drive. Wheel retracts to within 7-5/8" of the top of the tongue when trailering.

Rigid Jack Specs	Model	Type	Mounting	Capacity	Wheel/Foot	Travel	Maximum Tongue Height	Maximum Tongue Size
	6414	Screw	Rigid-Side Mount	1000 lb/454 kg	Wheel	15"	25-1/2"	3" x 5"
	6418	Screw	A-Frame	1000 lb/454 kg	Separate	15"	29-3/4"	N/A
	6740	Rack	Rigid-Top Mount	800 lb/363 kg	Wheel	18-3/8"	26"	3" x 5"
	6814	Screw	Rigid-Side Mount	1250 lb/567 kg	Wheel	15"	25-1/4"	3" x 5"
	6816	Screw	Rigid-Side Mount	2000 lb/908 kg	Foot	15"	23-1/2"	3" x 5"
	6817	Screw	Rigid-Side Mount	1250 lb/567 kg	Wheel	15"	26-1/8"	3" x 5"
	6820	Screw/Drop Leg	Rigid-Side Mount	2000 lb/908 kg	Foot	15"	38"	3" x 5"

* All models have side wind handle, except 6817, which is top wind.

A-Frame



6418
1000 lb capacity. Rigid A-frame mount screw-type tongue jack. Fits standard A-frame trailer couplers. Removable foot or wheel sold separately.



6604 Removable Wheel Fits 6418 Jack
Tough polypropylene wheel and bracket. 1000 lb capacity. Includes quick attach pin.



6606 Removable Foot Fits 6418 Jack
Steel support foot. 1000 lb capacity. Includes quick attach pin.



Manufactured in the

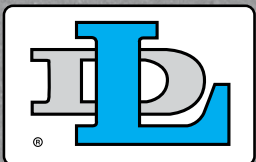



AG-INDUSTRIAL JACKS

D-L Goldenrod ag-industrial jacks are used for lifting and leveling applications. Precision rolled Acme thread inner screw, heavy duty thrust bearing, and heavy gauge steel outer and inner tubes for long life, easy cranking, and smooth, trouble-free operation.



6621 - 10" travel
6624 - 15" travel
2000 lb capacity

Swivel mount, side-wind. Includes 6616 weld-on bracket and 6617 snap ring.



6631 - 10" travel
6634 - 15" travel
2000 lb capacity

Swivel mount, top-wind. Includes 6616 weld-on bracket and 6617 snap ring.



6620 - 10" travel
6623 - 15" travel
2000 lb capacity

Tube mount, side-wind. Includes 6615 weld-on tube and 6618 pin.



6630 - 10" travel
6633 - 15" travel
2000 lb capacity

Tube mount, top-wind. Includes 6615 weld-on tube and 6618 pin.

6675 - 15" travel
5000 lb capacity

Ag-Industrial Jack Specs	Model	Mounting Style	Handle Type	Capacity	Travel	Overall Height (1)	Bracket Height (2)
	6620	6615 Tube Mount Incl.	Side	2000 lb/908 kg	10"	18"	11-1/2"
	6621	6616 Weld-On Bkt. Incl.	Side	2000 lb/908 kg	10"	18"	11-1/2"
	6623	6615 Tube Mount Incl.	Side	2000 lb/908 kg	15"	27"	15"
	6624	6616 Weld-On Bkt. Incl.	Side	2000 lb/908 kg	15"	27"	15"
	6630	6615 Tube Mount Incl.	Top	2000 lb/908 kg	10"	15-1/2"	11-1/4"
	6631	6616 Weld-On Bkt. Incl.	Top	2000 lb/908 kg	10"	15-1/2"	11-1/4"
	6633	6615 Tube Mount Incl.	Top	2000 lb/908 kg	15"	24-3/4"	14-3/4"
	6634	6616 Weld-On Bkt. Incl.	Top	2000 lb/908 kg	15"	24-3/4"	14-3/4"
	6675	6615 Tube Mount Incl.	Top	5000 lb/2270 kg	15"	24-3/4"	14-3/4"
	7201	Bolt-On (Sq. Tube) Drop Leg	Side	2500 lb/1134 kg	15"	23-1/2"	10-1/4" (3)



7201 (Imported)
2500 lb capacity.

Bolt-on, zinc plated with hardware, drop leg.



(1) Overall height is measured from top of jack to ground in retracted position, not including handle.
(2) Center of swivel point to ground when retracted.
(3) Top mounting hole to ground when retracted.



Heavy Duty A-Frame Jacks

6613A
1250 lb capacity
removable wheel
for A-Frame
Ag-Industrial Jacks.



6614A
5000 lb capacity
removable foot
for A-Frame
Ag-Industrial Jacks.



6670 - 2000 lb
6670B - 2000 lb
6671 - 5000 lb
6671B - 5000 lb

A-Frame Mount w/Top Handle

Welds or bolts to trailer.
Accepts 6614 foot.
When combined with 6613
wheel – capacity is 1250 lb.
6670B and 6671B include
6612 support plate
for additional rigidity.
(See diagram below.)

A-Frame Ag-Industrial Jack Specifications

Model	Mounting Style	Handle Type	Capacity	Travel	Overall Height (2)	Bracket Height
6670	A-Frame	Top	2000 lb/908 kg	14"	20-1/2"	8-1/4"
6670B	A-Frame (1)	Top	2000 lb/908 kg	14"	20-1/2"	8-1/4"
6671	A-Frame	Top	5000 lb/2270 kg	14"	20-1/2"	10-1/4"
6671B	A-Frame (1)	Top	5000 lb/2270 kg	14"	20-1/2"	10-1/4"

(1) 6612 support plate included.

(2) Overall height is measured from top of jack to ground in retracted position, not including handle

Manufactured in the

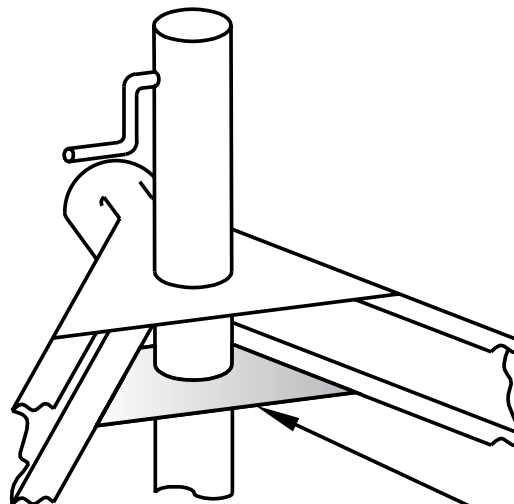
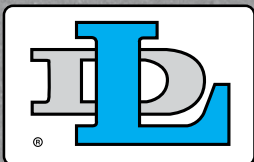

The support bracket (also sold separately as model 6612 on pg. 23) is included with A-frame jacks with a "B" following the model number – 6670B, 6671B. It comes unfinished, ready to be welded to underside of trailer. This bracket provides extra stability to the jack, so it won't "lean" under load.

6612 Support Bracket

JACK ACCESSORIES AND PARTS

6600 Tongue Jack Stand

For use with D-L tongue jacks. Black, powder-coated steel. Comes in 4 pieces, some assembly required. UPS/FedEx shippable. Jack and coupler not included.



6608 Wheel Lock



Fits most tongue jacks with 6" wheel. Grips wheel to eliminate wheel roll. Step on one end to lock, opposite end to release. Kit includes locking lever, cam and 1/2" x 3-1/2" mounting bolt.

6802 Dual poly wheel for 6800 Tongue Jacks.

6804 Mounting hardware for pivot jacks. All models.

6805 6" heavy duty wheel for 1250 lb models.

6806 6" wheel for 1200 lb capacity models or below.

6807 8" heavy duty wheel, fits 6850 and 6851.

6808 Swivel plate kit for 4-bolt mount pivot jacks. Specify 3/8" or 1/2" swivel pin.



6809 Swivel plate kit for 2-bolt mount pivot jacks. Specify 3/8" or 1/2" swivel pin.

6810A Side handle for jacks with 2" outer tube with date code after 4296 (week 42 of 1996). Includes roll pin.

6811A Side handle for jacks with 2-1/4" outer tube with date code after 4296 (week 42 of 1996). Includes roll pin.

6812 Gear and bearing kit for jacks with date code before 4296 (week 42 of 1996).

6812A Gear and bearing kit for jacks with 2" outer tube with date code between 4296 (week 42 of 1996) and 3397 (week 33 of 1997).

6812B Gear and bearing kit for jacks with 2" outer tube with date code after 3397 (week 33 of 1997).



6813A Gear and bearing kit for jacks with 2-1/4" outer tube with date code after 4296 (week 42 of 1996).

6601
Top cap, 2".
Fits 6400 series jacks.



6602
Top cap, 2-1/4".
Fits 6600 and 6800 series jacks.



6610
Weld-on swivel bracket fits all D-L swivel jacks with 1/2" pins.



6612
Support bracket for A-frame ag-jacks.



6615
2" weld-on mounting tube.



6616
4" x 5" weld-on mounting bracket, fits all D-L swivel jacks with 1/2" pins.



6611
4" x 5" weld-on mounting bracket, fits all D-L swivel jacks with 3/8" pins.



6617
Snap ring.



6618
9/16" Detent pin.



6619
Top wind handle with bolt and nut.



6684 - 4-1/2"
6685 - 5-1/2"
6686 - 6-1/2"

Channel Mounting Brackets allow mounting any D-L swivel jack directly onto aluminum I-beam or channel with no overhanging bolts or straps. Brackets are available to fit 4-1/2", 5-1/2" or 6-1/2" I-beams. Mount with a total of four bolts; two in top and two in bottom flange.



ROLLER BUNKS AND ACCESSORIES

Roller Bunks

D-L roller bunks provide a quick, easy and inexpensive way to upgrade bunk-style trailers to rollers. Two different D-L designs are available, Original or Deluxe.

Both feature "2 compound" rollers with durable wear resistant inner surface and soft boat cushioning outer surface.

6354

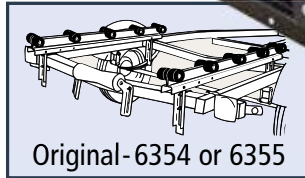

Original- 6354 or 6355

Original Design

Attaches directly to vertical mounted 2 x 4 bunk board, mounting bracket or can be mounted with optional No. 6356 bracket. Rollers self-align up to + or - 10° to fit shape of boat hull, 2 rollers per set. Constructed of 14 gauge steel in black powder coated finish. Sold in pairs.

6387

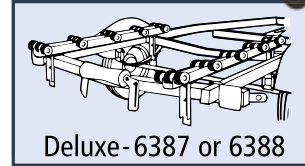

Deluxe-6387 or 6388

Deluxe Style

Universal mount attaches directly to either vertical or horizontal positioned bunk boards and features 3 rollers per set. Bracket 6389 optional. Constructed of 12 gauge pre-galvanized steel. Sold in pairs.

Roller Bunk Specifications

Model	Length	No. of Rollers	Finish	Boat Capacity
6354	4'	10 sets of 2	Black	2500 lb/1135 kg
6355	5'	12 sets of 2	Black	3000 lb/1362 kg
6387	4'	10 sets of 3	Galv.	2500 lb/1135 kg
6388	5'	12 sets of 3	Galv.	3000 lb/1362 kg

Roller bunk brackets allow bunks to be adjusted vertically and angled to cradle the boat hull. Refer to brackets above.

Rollers

Spool Rollers

6340 4"

6343 5"

For 5/8" shaft



Keel Rollers

6345 8"

6346 12"

For 5/8" shaft



End Caps

6336

2-1/2"

For 5/8" shaft

6337

2"

For 1/2" shaft



Rocker Rollers

6338 4-1/4" x 4-1/4"

6339 4-3/8" x 3" ribbed

For 3/4" shaft



Bow Roller

6347

3"

For 1/2" shaft



Molded Guide-On Rollers

6334

2-1/2" x 12"

For 5/8" shaft

6335

2" x 9"

For 1/2" shaft



6356
Roller bunk bracket fits 6354 and 6355 roller bunks.



6389
Roller bunk bracket fits 6387 and 6388 roller bunks.



Manufactured in the

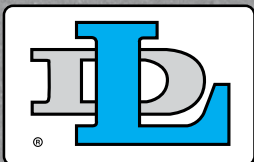

WHEEL BEARINGS & PROTECTORS



6332 Grease Keeper Caps

Snug fitting steel dust cap has grease zirk and pressure relief valve built-in. Protects and extends bearing life. Zirk permits frequent greasing and relief valve allows escape of excess pressure. Zinc plated finish. 2 protectors including dust covers per package.



6200

Trailer Wheel Bearing Sets

6500 series includes:

- ♦ 2 bearings with races
- ♦ 1 grease seal
- ♦ 1 cotter pin

6200 series includes:

- ♦ 2 bearings with races
- ♦ 1 grease seal
- ♦ 1 cotter pin
- ♦ 1 dust cap

Dust Caps

2 dust caps per package.

6526 3/4"

6527 1" & 1-1/16"

6528 1-1/4"



Dust Covers Only

2 dust covers for Grease Keeper caps per package.

6531 fits 6331

6532 fits 6332

6533 fits 6333

	Model	Spindle O.D.	Outer Hub I.D.	Outer Bearing Cone No.	Inner Bearing Cone No.	Outer Cup No.	Inner Cup No.	
								Wheel Bearings & Protectors Specifications
Wheel Bearing Sets	6200 & 6500	3/4"	1.781	LM11949	Same	LM11910	Same	
	6201 & 6501	3/4"	1.938	09067	Same	09195	Same	
	6202 & 6502	1"	1.980	L44643	Same	L44610	Same	
	6202-WBP	Same as 6202 with Wheel Bearing Protector Replacing Dust Cap						
	6203 & 6503	1-1/16"	1.980	L44649	Same	L44610	Same	
	6204 & 6504	1-1/4"	2.328	LM67048	Same	LM67010	Same	
	6205 & 6505	1-1/16" x 3/4"	1.781	LM11949	L44649	LM11910	L44610	
	6206 & 6506	1-1/4" x 3/4"	1.781	LM11949	LM67048	LM11910	LM67010	
	6207 & 6507	1-3/8" x 1-1/16"	1.980	L44649	L68149	L44610	L68111	
	6208 & 6508	1-3/8" x 1-1/16"	1.980	L44649	L68149	L44610	L68110	
Protectors	6331	3/4"	1.781	LM11949	—	LM11910	—	
	6332	1"	1.980	L44643	—	L44610	—	
	6332	1-1/16"	1.980	L44649	—	L44610	—	
	6333	1-1/4"	2.328	LM67048	—	LM67010	—	
Seals & Cotter Keys	6511	1-1/16"	1.980	Set of 2 ea. seals #203106 & 2 ea. Cotter keys #203814 for kits # 6202, 6203, 6205, 6502, 6503 & 6505.				
	6512	1-1/4"	2.328	Set of 2 ea. seals #203122 & 2 ea. Cotter keys #203814 for kits # 6204, 6206, 6504 & 6506.				
	6513	1-3/8"	2.561	Set of 2 ea. seals #203684 & 2 ea. Cotter keys #203814 for kits # 6207, 6208, 6507 & 6508				
	6514	3/4"	1.781	Set of 2 ea. seals #203612 & 2 ea. Cotter keys #203814 for kits # 6200 & 6500.				
	6515	3/4"	1.938	Set of 2 ea. seals #203100 & 2 ea. Cotter keys #203814 for kits # 6201 & 6501.				
Dust Caps	6526	3/4"	1.781	LM11949	—	LM11910	—	
	6527	1"	1.980	L44643	—	L44610	—	
	6527	1-1/16"	1.980	L44649	—	L44610	—	
	6528	1-1/4"	2.328	LM67048	—	LM67010	—	
6500 Series- same as 6200 Series, except no dust cap is included.								

Cut-Away View of Hub

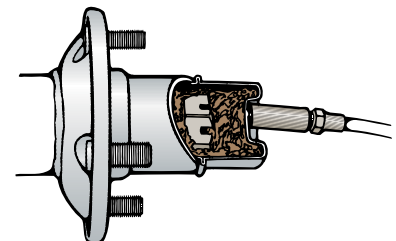
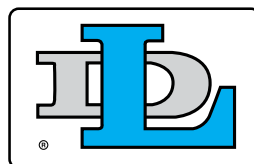
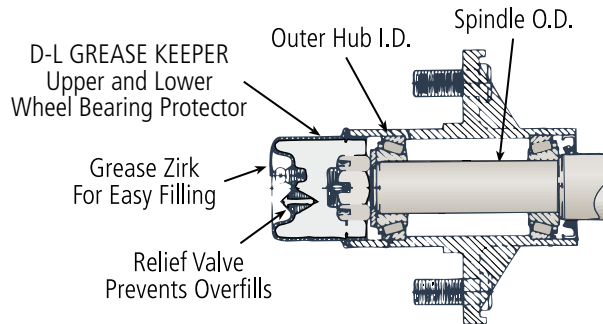

Cut-away showing grease being pumped into Grease Keeper cap.

HAND WINCH SELECTION GUIDE

General Winch Selection Guidelines

Because the high forces generated when using a winch create potential safety hazards, careful consideration should be given to the winch selection process. Safety should be a primary concern and questions such as what winch features are required for the application, what will be the experience level of the user, and what harsh environmental conditions will exist, should all be answered. More specifically, an important first question should be, "Does the application require the freewheel feature – the ability to pull cable freely from the drum to attach it to the load – available in ratchet-type pulling winches?" If not, a self-locking type winch – brake winch or worm gear winch – should be used. Generally, ratchet-type pulling winches are not recommended for lifting applications, and their use should be limited to horizontal or incline pulling operations requiring a freewheeling feature.

The experience or skill of the intended user is also important. For example, self-locking brake or worm gear type winches should generally be selected for rental equipment, even if the lack of a freewheel feature will make the operation slower or more cumbersome. This is because rental equipment will frequently be used by inexperienced operators unfamiliar with the safe use of the product, and self-locking winches reduce the skill and understanding necessary to operate a winch safely.

If the winch is likely to be used in a harsh environment, including such things as salt water, a potential for damage or abuse of the winch, or the likelihood of little or no periodic maintenance, then this should be factored into the winch selection. A larger size winch should possibly be selected, or guards on the product using the winch should be provided to protect the winch from damage or abuse.

It is sometimes difficult to determine the amount of load being pulled with a winch. All D-L hand winches are designed to pull their rated capacity with a force on the handle in the approximate range of 35 to 55 pounds. This means that the winch should be able to be cranked easily with one hand. If not, it is probably overloaded.

D-L winches are not designed to be used as hoists for lifting, supporting, or transporting people, or for loads over areas where people could be present. D-L winches are built to high quality standards, but do not include the features necessary to make them appropriate for moving of humans or overhead hoisting applications.



TUFFPLATE®

The Superior Zinc Plated Finish.

Zinc plated TUFFPLATE finish has 3 times the corrosion resistance of standard zinc plating process, and 30% greater corrosion resistance when compared to powder coated finish.

Results of laboratory tests using 5% neutral salt spray confirms our TUFFPLATE finish provides in excess of 500 hours against First Red Rust and in excess of 100 hours for First White Corrosion.

The exclusive TUFFPLATE finish process is standard on all D-L plated products. For additional information, contact your D-L sales representative or Dutton-Lainson Company.

Boat Weight To Winch Capacity Ratio

A commonly used ratio of boat size to winch capacity is 2 to 1. Example: a 2200 lb boat requires 1100 lb winch. There are, however, many factors to consider in selecting the proper size winch which are beyond the control of the winch manufacturer. For example, the ratio can sometimes be stretched to 3 to 1 when using a trailer equipped with good quality free-turning rollers maintained in excellent condition and most commonly used on ramps where the boat floats most of the way onto the trailer. The ratio should be reduced to as much as 1 to 1 on trailers using wooden bunks with no self-alignment capabilities, most frequently used on boat ramps requiring that the boat be winched a long way onto the trailer. Note that pontoon boat trailers and other special designs require special consideration to winch capacity selection.

Rolling Load Capacity

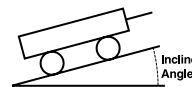

To calculate the rolling load capacity of a winch – the amount of load that can be pulled up an incline – multiply the winch capacity by the factor shown in the chart. The multiplication factor shown includes a 10% rolling friction factor.

Note: 5% incline is a 1/2 ft. rise in 10 ft.

% Incline	Multiply By:
Level Surface	10.0
5 (3°)	6.67
10 (6°)	5.02
20 (11°)	3.40
30 (17°)	2.61
50 (26°)	1.86
70 (35°)	1.53
100 (45°)	1.29



Left Side: Standard Zinc Plated
Right Side: Zinc Plated TUFFPLATE Finish





Sales Representatives

Domestic: United States

- 1 Derema Group Inc.**
33596 Avenida Calita
San Juan Capistrano,
CA 92675-4766
Tel: 949-545-6422
Fax: 949-361-5708
E-mail: cderecat@derema.com
Web Site: www.derema.com
Alaska, Arizona, California,
Colorado, Hawaii, Idaho,
Montana, Nevada, New Mexico,
Oregon, Utah, Washington,
Wyoming
- 2 S.M. Osgood Company**
7488 W. 78th St.
Bloomington, MN 55439
Tel: 952-937-2045
Fax: 952-937-9667
E-mail: tim.luehmann@smosgood.com
Web Site: www.smosgood.com
Illinois, Iowa, Minnesota,
Missouri, North Dakota,
South Dakota, Wisconsin
- 3 Dutton-Lainson Company**
451 W. Second St.
Hastings, NE 68902
Tel: 402-462-4141
Fax: 402-460-4612
E-mail: dlsales@dutton-lainson.com
Web Site: www.dutton-lainson.com
Kansas, Nebraska

- 4 Waters & David Co.**
8200 Hampson St., Suite 300
New Orleans, LA 70118
Tel: 504-866-8484
Fax: 504-866-2424
E-mail: office@watersanddavid.com
Web Site: www.watersanddavid.com
Arkansas, Louisiana,
Oklahoma, Texas

- 5 Impact Marketing Group**
675 E. 16th St.
Holland, MI 49423
Tel: 616-392-7720
E-mail: impactmarketing@ameritech.net
Indiana, Kentucky, Michigan, Ohio

- 6 Advanced Marketing Southeast, Inc.**
580 NE 45 Terrace
Ocala, FL 34470-1496
Tel: 352-342-1460
Fax: 352-690-7303
E-mail: johntfye@gmail.com
Web Site: www.amsmarketing.com
Warehouse: 13 N.E. 16th St.
Ocala, FL 34470-4108
Tel: 352-867-7711
Fax: 352-867-7858
Alabama, Florida, Georgia,
Mississippi, North Carolina,
South Carolina, Tennessee

- 7 Derema Group Inc.**
831 Lincoln Ave., Unit 11
West Chester, PA 19380
Tel: 610-431-3800
Fax: 610-431-3807
E-mail: jcarney@derema.com
Web Site: www.derema.com
Connecticut, Delaware, District of
Columbia, Maine, Maryland,
Massachusetts, New Hampshire,
New Jersey, New York,
Pennsylvania, Rhode Island,
Vermont, Virginia, West Virginia
- 8 Nemrow Sales Company
OEM Sales Specialist**
4195 Chino Hills Pkwy #617
Chino Hills, CA 91709
Tel: 909-548-2196
Fax: 909-548-2198
E-mail: blainnemrow@hotmail.com
California

Export: Canada

- 9 Canada-Sales office
and warehouse:
Woodard & Company, Ltd.**
329 Rayette Road, Unit 3
Vaughan, ON
Canada L4K 2G1
Tel: 905-760-0245
Fax: 905-760-0250
E-mail: john.reid@woodardcompany.com

Export: Worldwide (and all other countries not shown)

**Dutton-Lainson Company
Export Department**
451 W. Second St.
Hastings, NE 68902
Tel: 402-462-4141
Fax: 402-460-4612

Bainbridge International Ltd.
8 Flanders Park
Hedge End, Southampton
Hants, England SO30 2FZ
Tel: +44 (0) 1489-776050
Fax: +44 (0) 1489-776055
E-mail: info@bainbridgeint.co.uk
Web Site: www.bainbridgemarine.co.uk
Europe, Middle East,
South Africa

PWB Anchor Limited
441 Grimshaw St.
P.O. Box 77
Bundoora, Victoria
Australia 3083
Tel: +61 3 9467-2933
Fax: +61 3 9467-7290
E-mail: vicsales@pwbanchor.com.au
Web Site: www.pwbanchor.com.au
Australia, Papua, New Guinea,
New Zealand, Malaysia

E & P Marine Inc.
2425 N.W. 33rd Ave.
Miami, FL 33142
USA
Tel: 305-634-6110
Fax: 305-634-1191
E-mail: info@epmarine.com
www.epmarine.com
Central and South America,
Mexico, Caribbean,
including Bermuda

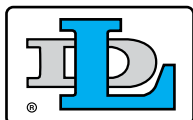

A Dependable Company Since 1886
DUTTON-LAINSON COMPANY
Hastings, NE U.S.A. 68902 • Tel 402-462-4141 • Fax 402-460-4612
www.dutton-lainson.com • E-mail dlsales@dutton-lainson.com





A Dependable Company Since 1886

DUTTON-LAINSON COMPANY

Hastings, NE U.S.A. 68902 • Tel 402-462-4141 • Fax 402-460-4612
www.dutton-lainson.com • E-mail dlsales@dutton-lainson.com



ISO 9001:2008 REGISTERED Q.M.S.

